

Design for All

ENGAGING THE DESIGN STUDENTS





From the Editor's Desk

Knowledge and empathy nurtures wisdom. Enabling and sharing lays the foundation for an altruistic society. Respecting the feelings, opinions and needs of others while holding the wealth of a nation as a common trust of all citizens, is the basis of a democratic society.

Our education system has focussed entirely on knowledge. It has neglected empathy. Education has become increasingly text book centred. Knowledge and its learning has been test paper tested. In the process it has killed creativity, innovation and caring. It has nurtured cut throat competition and in the process killed sharing and teamwork. Consequently wisdom, altruism and the spirit of democracy have suffered full maturation. Experiencing people, society, culture and environment has been relegated to the backyard. Over the time kept raising the bench mark of minimum education for a few. This has resulted in students living and growing in the class room cocoon. Their adolescence had to be extended. Finally when they emerged, the choice was being picked by a company. The companies and their corporate objectives, decided how the youth of this nation shaped the country's future destiny. A highly respected teacher once remarked " Students can change the world but they don't know where they

should begin". Students need an opportunity to discover their emotional equation with the world around them. Once they discover their resonance frequency, their rapport with their environment increases many fold and they are able to see a purpose and meaning in their life and their learnings.

India ranks eleventh in the world in its number of active scientific and technical personnel. India's annual enrollment of scientists, engineers and technicians now exceeds 2 million. While they are in college they are only accumulating knowledge, and merely looking forward to a job. They have no vision for the society or country they would like to leave behind for the future generations and what role they would emotionally feel committed to play in the process of change. This state of apathy and vacuum is not confined to India alone. It very much a reality all over the world's education systems. Change is visible. Experiential learning is taking root. Service learning programs in US and European countries is very much part of this realization.

Department of Science and Technology, a premier government institution is concerned with policies and research funding of science and technology research projects in India. It has many divisions. One of them is Science and Society Division. Under this, there is a program called TIE (Technology Intervention for the Elderly). Two years back under the visionary leadership of Raghav Saha, the division took the initiative of sponsoring fellowships and project prototyping assistance for the design students at IIT Delhi and IIT Bombay. The objective was creating awareness among the students about the elderly and

strategically involving them in product concept development for the elderly.

This issue brings you some of the work done at the M.Des. Industrial Design Program, IIT Delhi and the School of Planning & Architecture, Delhi. In a future issue we plan to present the work done at IIT Bombay by Prof. G. G. Ray and his team.

The initiative has been a fair success and worthy of being extended to other institutions. If this is done then DST will experience a new opportunity of delivering benefits of science, technology, design and entrepreneurship through young graduates. Experiential learning will take up a new dimension. Productivity in Science & Technology development will increase many fold. Education too will receive a major boost by enabling students to work on real life problems concerned with the society and industry. Many students have dreams for our country but they have no financial support to demonstrate their dreams. Time we gave them a place to stand and I am sure they will move the earth for the better. A mere `100 crore can finance 10,000 graduate engineers and technologists to realize and present their dreams for a better life. We need somebody to champion this 'DREAM'. Hope DST will take the bait and unleash the potential called India.

Happy reading and I look forward to more student work from around the world.

With best wishes

Lalit Kumar Das

Content of August 2010 Vol-5, No-8

1. Editor's Note:	2
2. The Context of the Elderly in India: Creating awareness among the students and their strategic involvement in product concept development:	8
3. Electric scooter for elderly:	15
4. Cycle for elderly:	18
5. Rickshaw for elderly:	21
6. Ambulance quad-bike for villages in rural India:	26
7. Nail cutter for elderly:	29
8. Mobile phone for elderly:	31
9. Luggage for elderly:	36
10. Kitchen unit for elderly women:	39
11. Assistive device for wearing socks for elderly:	42
12. Comfort shoes for Elderly:	44
13. Assistive device for Stroke Patient:	47
14. Staircase climbing walker for elderly:	51
15. Bathroom for the elderly:	54
16. Three wheeler ambulance for congested roads:	57
17. TRANSX: A bathe support aid:	59
18. Mobil-e: Motorized Wheelchair:	69
19. Bude design of car for elderly with focus on ingress and egress:	73
19I' Boy - Design of car for elderly with focus on ingress and egress:	79
20Accessibility Audit at Taj Mahal:	81
21Chairman's Desk:	83

Other regular features

Forthcoming issues:

September 2010 Vol-5, No-9

I'M OLD AND I CANNOT SEE-A REHAB DILEMMA

Dr. Roberta Null

**ACCESSIBILITY PLANNING IN SPAIN – LEGAL
FRAMEWORK AND PLANNING TOOLS**

Molero González, José Ángel / Rebstock, Markus

***Transport an Spatial Planning Institute, University of Applied
Sciences Erfurt, Germany***

HIMALAYA ON WHEELS!

Vidhya Kalyani Rmasubban

October 2010 Vol-5, No-10

1. Prof Lalita Sen, Texas University, USA

2. Ms Onny En of Inclusive

3. Mr Abhimany Singh, Cumulus

January 2011 Vol-6, No-1

January 2011 issue is special issue with The New Zealand Tourism Research Institute at The Auckland University of Technology and the Guest Editor is Dr. Sandra Rhodda



***Dr. Sandra Rhodda
Senior Research Officer***



Lalit Kumar Das

IRD Fellow, IIT Delhi

lalitdas@gmail.com

**The Context of the Elderly in India:
Creating awareness among the students
and their strategic involvement in
product concept development**

Lalit Kumar Das

The elderly account for more than 9 percent of the total population. The National Population Commission has estimated that the population of the elderly (age group 60 years and above) is expected to grow from 71 million in 2001 to 173 million in 2026. It is further estimated that the urban population would increase from 28 percent in 2001 to 38 percent by 2026; the urban growth would account for over two-thirds (67 percent) of total population increase by 2026. Out of the total population increase of 371 million during 2001-2026 in the country, the share of increase in urban population is expected to be 249 million.

The demographic scenario appears to indicate a very precarious condition for the older persons. While the elderly in the age group 60-69 years could be expected to lead a fairly healthy life and offer their services as volunteers for informal care giving to the elderly in the two higher age groups, both the 70-79 years age group and the 80 + years age group would require critical social and medical health care support – both informal care giving and formal care giving. The two higher age groups were 49.12 million as per the 2001 Census, with almost more than two-thirds living in India’s rural areas. The males among this total segment of the elderly accounted for 22.75 million; the females were around 26.37 million.

The elderly population in India, when categorized in terms of the three age groups as per the Census of 2001, demonstrates the following picture:

Percentage of old persons to total population by sex

Age group	percent to total population by sex		
	Person	Male	Female
60-69 years	4.5	4.3	4.7
70-79 years	2.1	2.0	2.1
80+ years	0.3	0.3	0.3
Total	6.9	6.6	7.1

The National Policy on Older Persons 1999, having taken note of the demographic scenario, had noted that several factors, including adoption of small family norm by a growing number of people, would create a situation where the country would face a scarcity of care givers. It projected the following situation:

“...Changing roles and expectations of women, their concepts of privacy and space, desire not to be encumbered by caring responsibilities of old people for long periods, career ambitions, and employment outside the home implies considerably reduced time for care giving. ... The position of single persons, particularly females, is more vulnerable in old age as few persons are willing to take care of non-linear relatives. So also is the situation of widows an overwhelming majority of whom have no independent source of income, do not own assets and are totally dependent.”

The rapidly growing number of older persons, more older women than men, combined with the rapidly declining number of traditional care providers within the family, the marked absence of any public policy on either home-based health care or training of cadres of professional care providers for the home-based older persons, and the sky-rocketing costs of hospitalization could lead to a situation where the older persons would either resort to avoidance of diagnostic and curative

health opportunities or face abandonment by their families, children or relatives.

Old Age Homes have rapidly emerged in the urban and semi-urban areas as an attractive shelter product for the elderly since they are assured of a peer-group community living.

Designing for the Elderly

The concept of “Design for Elderly” is new in India which needs to be nurtured and inducted among the younger generation for a better tomorrow. One of the possible way of bringing awareness is involving youngsters through their academics and research. Let them concentrate totally on the issues of elderly, learn about the elderly, observe them closely, identify their needs, bring out the issues, fulfill their requirements.

As a first experiment to this venture, the Department of Science and Technology selected IITs as a platform where through the flexible academic curriculum at the M.Des level one can induct a new elective in the existing course curriculum which can gradually be explored as a full-fledged specialized course on “Design for the Elderly and physically challenged”.

While IITs have this built-in flexibility, there is some rule according to which the minimum no of students to run a

course is preferred as five. Accordingly it is proposed that the DST can sponsor ten M.Tech level (Jr. Engineer) fellowships, five for each of IIT Bombay and IIT Delhi. Only those students who will be motivated to develop their carrier on designing for the elderly and physically challenged, will be allowed to take up the elective and will enjoy the fellowship for two years (four Semesters) during their design course curriculum. During their study they have to take up projects initially related to the Elderly and at the end of the program each student has to deliver a functional prototype. Thus after a decade from now we will have one hundred prototypes on different problem areas of the elderly which can further be taken up for commercial ventures.

This experiment was initially sanctioned for two years. It was coordinated at IIT Bombay by Prof G.G. Ray and at IIT Delhi by myself. Each IIT selected five students to pursue their work. Financial support was available for prototype development. It was possible to extend this support to other institutes where students wanted to work on technological and design intervention for the care of the elderly.

This issue shows cases the work done by the students of at IIT Delhi and School of Planning and Architecture. In a future issue we will showcase the work done at IIT Bombay under the leadership of Prof. G.G. Ray at the Industrial Design Centre.

In an earlier issue of Design for All Institute of India we have already showcased the 'Bude'- designed by Dinesh Verma and Ol' Boy – designed by Ringlarei Pamei. Both the efforts focused on easy ingress and egress.



'Bude'- designed by Dinesh Verma



Ol'Boy designed by Ringleri Pami

Another study 'Body storming at Taj was also feathered in an earlier issue. Such studies are important to auditing the accessibility features of tourist spots for elderly and the differently enabled.



Lugging a wheelchair up the stairs leading to Taj Mahal Mouseleum

This experiment of promoting concern for the elderly among the creative design students and their strategic involvement in product development was a resounding success. We thank Department of Science & Technology for the sponsorship.

Lalit Kumar Das

IRD Fellow, IIT Delhi

lalitdas@gmail.com



Title: Electric scooter for elderly

Name of the Designer & Address: Tinton Abraham

Email: tinton.abraham@gmail.com

Problem Perceived:

An electric vehicle specially designer to cater all the needs of elderly as well as others who wish a comfortable ride.

Solution Provided:

- **Enough leg space**
- **Self balanced**
- **Windshield to protect fro rain and dust**
- **Enough luggage space**
- **Big foot boards**
- **Easy ingress and egress for driver and pillion rider**

CAD Model, Picture / Drawing

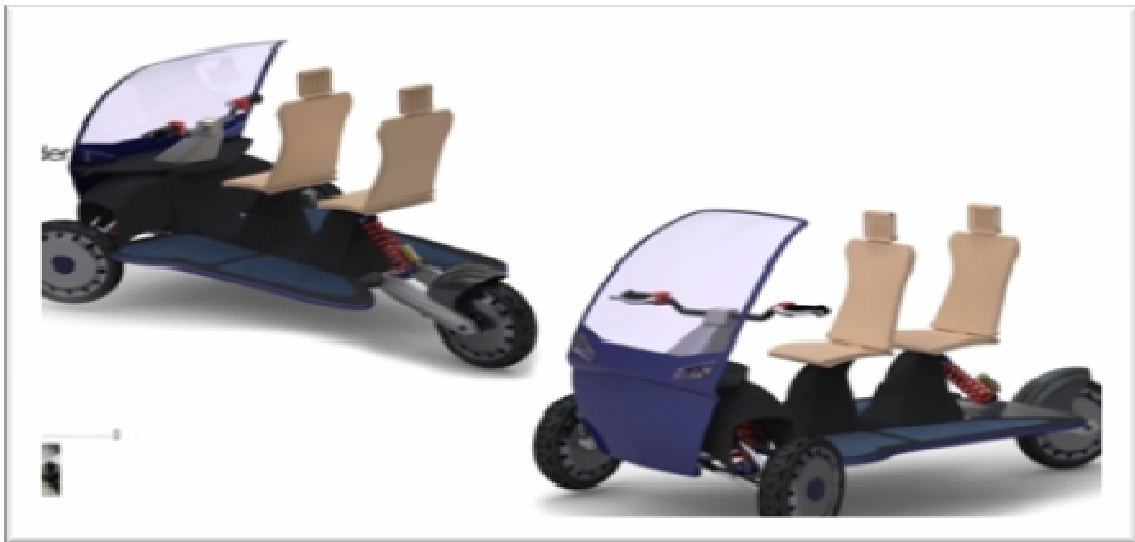
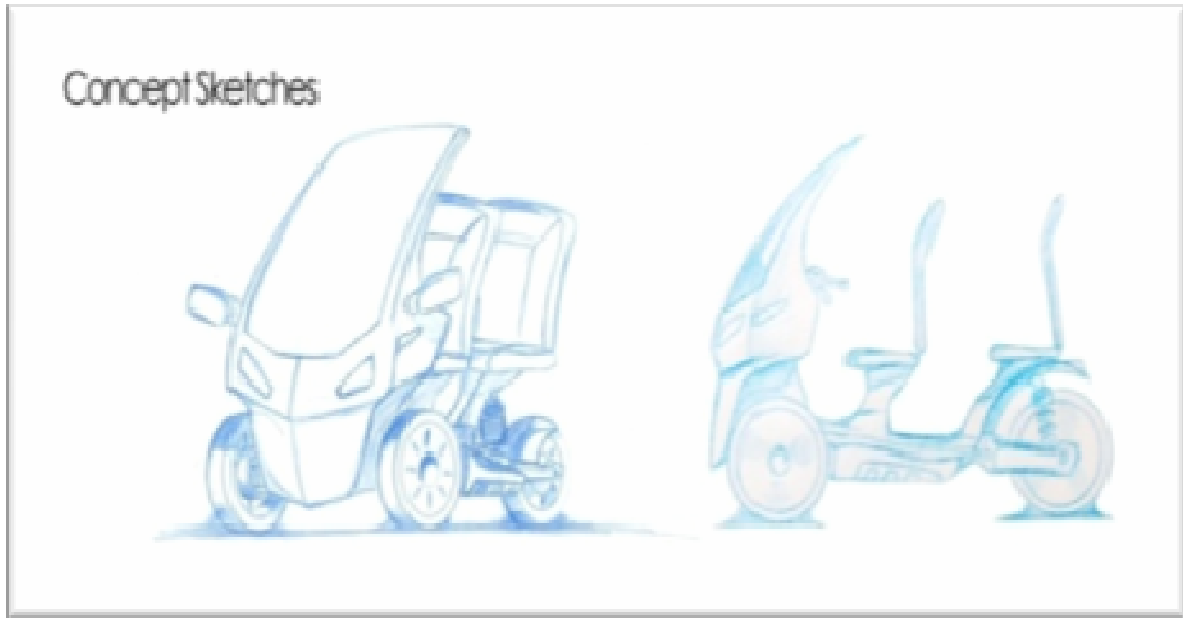

Status of Design Developed

1:1 working model has been developed with following specifications:

- **650 watts brushless dc motor**
- **350.10'' tyres**
- **Front- double wishbone suspension**
- **Rear- mono suspension**
- **50 km/hour**
- **40 kms for a full charge**



Suggestion

Experienced flaws while testing the product shall be overcome and get solutions to them.



Title: Cycle for elderly

Name of the Designer & Address: Vishal Raj

Problem Perceived:

The aim of the project is to design a cycle for elderly, which would enhance the mobility of the elderly and act as a means of exercise. Cycles are widely used for transportation & carrying loads and there is no special cycle for elderly.

Solution Provided:

A multi activity cycle for elderly was developed which helps To keep body and mind healthy No need for special exercise equipment. Ladies can be encouraged to cycle. Small distance commuting & activities like ride in the park can be encouraged.

CAD Model, Picture / Drawing:

Step one



Bicycle mode
Fun & Fast



Step two

Detach - Attach
Change of forks



Step three

Tricycle mode
Balance & Stability



Step four

Trolley mode
Shopping

relive the joy of cycling



Prototype

Tricycle mode



Status of Design Developed:

Prototype and CAD model

Suggestion:

The width of the cycle need to be reduced, but also the turning mechanism is to be taken into consideration while doing this. The attach-detach option can be simplified and made more effortless and graceful.



Bharat J.

***"Gokul", TC 43/163, Kamaleshwaram,
Aryankuzhi Temple Road, Manacaud.P.O,
Trivandrum, Kerala – 695009***

Title: Rickshaw for elderly

***Title: Re-design of CYCLE RICKSHAW for easy
ingress/egress of elderly.***

Bharat J.

Problem Perceived:

The major problems involved were :

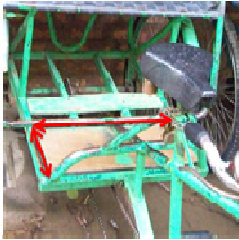

The footboard area is too less for a passenger to climb, turn and have a seat comfortably.



Very high food board height from the floor of more than 50cms. This tends to concern people with crutches or an elderly while climbing.



Space provided for entering is small and the obstacles may cause accidental falls



No proper support for ingress provided. The frame is used as handle.

Solution Provided:

- 1. By integrating the chassis and the seat body, the height of the rickshaw footboard could be brought down to a stair height (25cm)**
- 2. Separate support handles are provided for proper grip/hold.**
- 3. The footboard is kept clear from any obstacle and its area is increased so that the passenger could stand, turn and then sit on it.**
- 4. The luggage space is provided at the back of the rickshaw, where the passenger can stand and then access.**
- 5. Battery/Tool Box area is provided for the rickshaw puller, which can be used to keep his personal belongings.**
- 6. The passenger seating height is lowered to the rickshaw puller height, which eases the effort for the rickshaw puller.**

CAD Model, Picture / Drawing:



Status of Design Developed:

Prototype of human powered low floor cycle rickshaw was made and tested for its load bearing capacity.



Suggestions:

Since the project was basically for the ingress/egress of elderly passengers, not much work was done on making it easier for the rickshaw puller. However, if the front wheel can be replaced by a motor (electric hub), that can assist the puller, then the project will also take care of the elderly rickshaw puller. The product would be complete take care of the elderly, both passengers and the rickshaw driver.





Title: Ambulance quad-bike for villages in rural India

Name of the Designer & Address: Tinton Abraham

Email: tinton.abraham@gmail.com

Problem Perceived:

An ambulance vehicle with the aim of improving emergency transit times for the disables and the elderly people in areas where motorized transport is unavailable or inappropriate.

Solution Provided:

with a focus on patient comfort, safety and accessibility, the quad bike ambulance was designed to be affordable and which can be maintained by village county members.

ATV is made as a standalone vehicle, since critical emergency is very rare in villages.

CAD Model, Picture / Drawing:

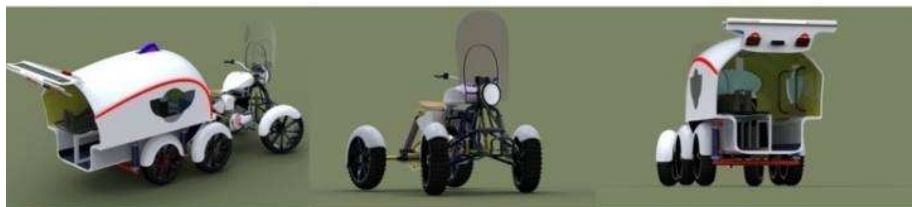
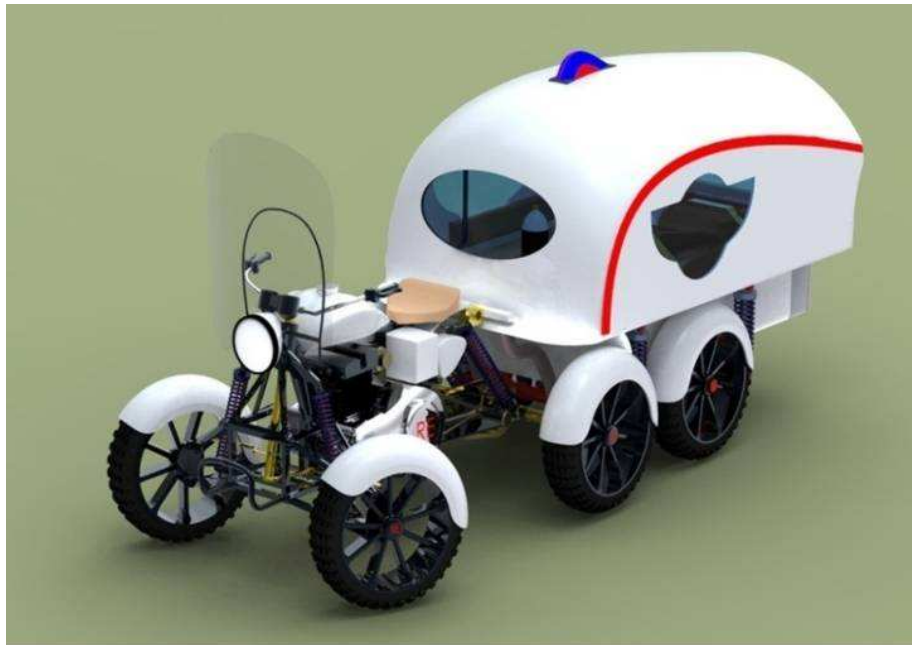
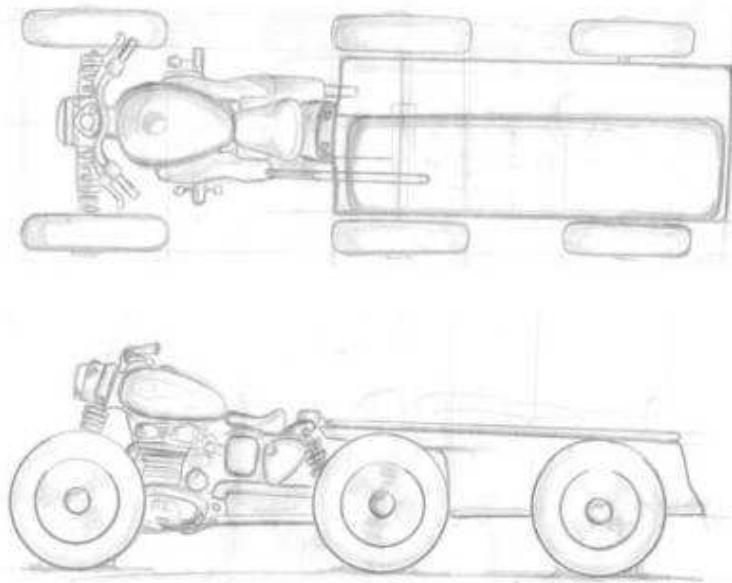

Status of Design Developed

Rapid prototype of the design is developed which was displayed in auto-expo 2010



Suggestion:

1:1 product working prototype shall be developed.



Pawan Pagaria

Title: Nail cutter for elderly

Pawan Pagaria

Problem Perceived:

With old age, body flexibility reduces, eyesight becomes weak, hands don't have enough strength and they tremble.

Consequently nail cutting activity using the regular nail cutter becomes difficult. There is a need to relook at the design for the nail cutter for the elderly.

Solution Provided:

The designed nail cutter had long grip for good holding and the cutting edge was provided on the two sides for ease of cutting and comfortable viewing. Provision was also made for attaching a magnifying glass.

CAD Model, Picture / Drawing:



Status of Design Developed:

Prototype was made to simulate the usability.

Suggestion:

Prototype should be given to a group of aged people to use and feedback should be recorded to refine the design.

Prototype Development:

Manufactures of nail cutters should be approached to take the product forward.



Title: Mobile phone for elderly

Name of the Designer & Address: Vishal

Problem Perceived:

Primary – Receive a call and Make a call, identify callers, identify senders from directory. Send pre-programmed messages

Secondary –Send keyed message

Firm grip (means to hold the phone firm while operating or in use)

Approach: Design methods were used to understand the problem and visualize solutions.

Step one

Elderly Needs

Physiological Needs

Safety Needs
seeking help in case of emergency

Social Needs
communication

Step two

Preliminary Survey

Interviewing Users

Remarks from published papers

Step three

Observing for sequence of action (s)

Max Hospital - New Delhi

Cognitive Dysfunctions

One of the greatest health problems of elderly

Poor mental function, confusion, forgetfulness

Step four

Analysis of study

Cognitive Dysfunctions - Factors

Long Term Retrieval



"I need to make a phone call to my son"



"How do I make a call?"



Scenario

"Cannot recall how to make a call!"

Short Term Memory



"Dad I call home after I put down the phone"



"What did he say?"

Scenario



"Home?"

Freedom from Distraction



"Have to call my son"



"Ah! Should meet my friend in the park"

Scenario

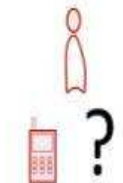

"What was I thinking before?"

target not the differences between mobiles phones but rather the problematic commonality between them

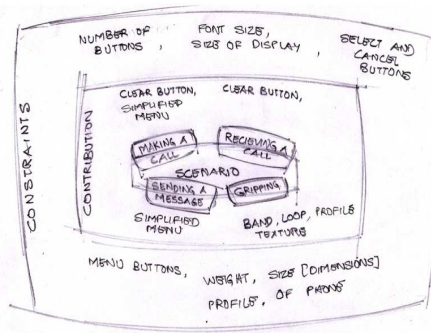

Framework

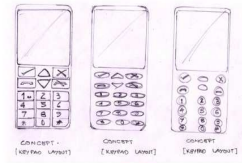

Concept Alternatives

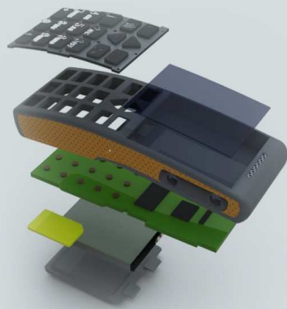
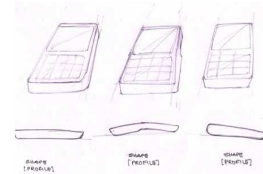

Concept Detailing

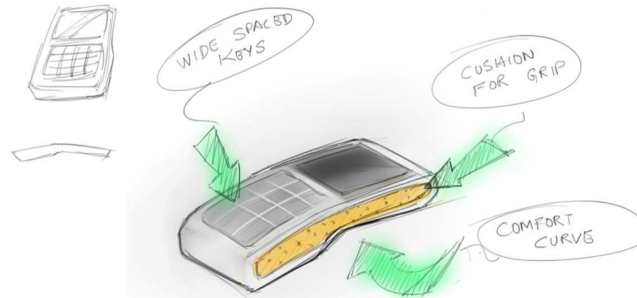

Concept Selection

MOBILE PHONE FOR ELDERLY 
 Project done by : M.Vishal Raj

Difficulty to view with bifocal lens

Comfort curve design provides viewing angle in +30 to -30 deg

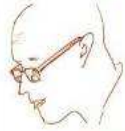

Difficulty to pick up and grip

Comfort curve design allows for easy picking up

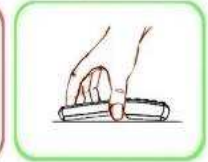

Slippage

Wider base and cushion for grip

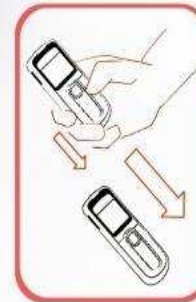

Confusion due to wrong key press and lack of dexterity

Spaced keys

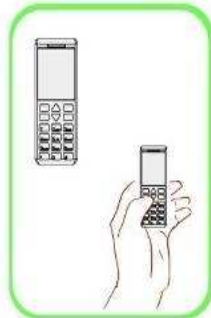

Small notch

Wider back panel for easy removal

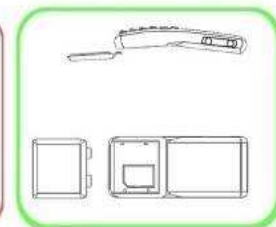
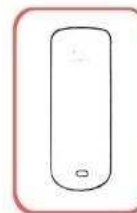

User Interface:

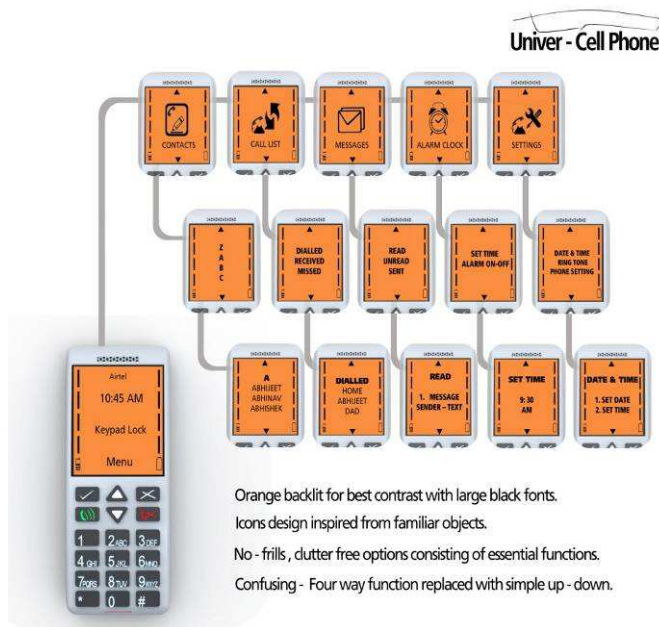

Solution Provided:

Easy to view, grip, and operate with a well spaced keypad. Picture and nick named based directory. Large letters are used in display. No auto scrolling. Easy to make and receive calls through distinctive easy to recognize call and receive buttons.

CAD Model, Picture / Drawing:

Only concept sketches and CAD model made.

Status of Design Developed:

CAD model

Suggestion:

The buttons can be eliminated or the phone can be made clutter free. The main focus should lie on how the make the phone smaller without compromising on the usability.



Title: Luggage for elderly

Name of the Designer & Address: Vishal Raj

Problem Perceived:

Elderly people's need become more specific and they are at a greater risk during the travel time. No specialized products available that cater to needs of elderly during travel time. The elderly use the regular suitcases, which are heavy or bags which are not specially designed to meet their travel needs. Portability and stability during strolling are important issues. Further accessibility to content while it is on the ground is still another issue.

Solution Provided:

A Luggage which - Uses cheaper materials, preferably locally available luggage can be pushed / pulled (has wheels).

Luggage can stand/support on its own has sufficient pockets for specific things to easily remember to carry

CAD Model, Picture / Drawing:



Status of Design Developed:

Testing Prototype Made. Actual one has to be done.

Suggestion:

The push pull mechanism still needs effort and also there are issues with the locking mechanism (safety) of the suitcase.

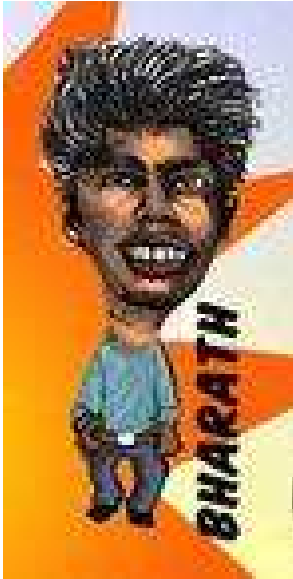

Title: Kitchen unit for elderly women

Name of the Designer & Address:

Bharat J.

***"Gokul", TC 43/163, Kamaleshwaram,
Aryankuzhi Temple Road, Manacaud.P.O,
Trivandrum, Kerala – 695009***

Problem Perceived:

Indian Kitchens have space constraints. The shelves are mostly unused because of reach and accessibility issues, especially for elderly and the middle aged Thus by making the space available we can reduce the clutter on work area.

Solution Provided:

A mechanism that could bring the shelf to an accessible reach, instead of reaching for it would be convenient.

The STRUT mechanism was adopted from the boot-space door of hatchback car along with 4-Bar mechanism to maintain stability



CAD Model, Picture / Drawing:



Body can be made in Wood or even plastic.
This is fixed to the wall.

The aluminium racks are removable and provides the user with an option to customize based on the space requirement.



Doors are made of Plastic
A transparent section allows the user to view what is inside before opening.
Once closed, the door auto-locks to the body.

The inner shelves are made of light aluminium.
This reduces the overall weight as well as increases strength.



Status of Design Developed:

Concept Stage: CAD Model

Suggestion:

Prototyping should be made and tried out.



Title: Assistive device for wearing socks for elderly

Name of the Designer & Address: Bharat

Problem Perceived: Bending and wearing socks

Solution Provided: Attachment to walking stick for wearing socks

CAD Model, Picture / Drawing:

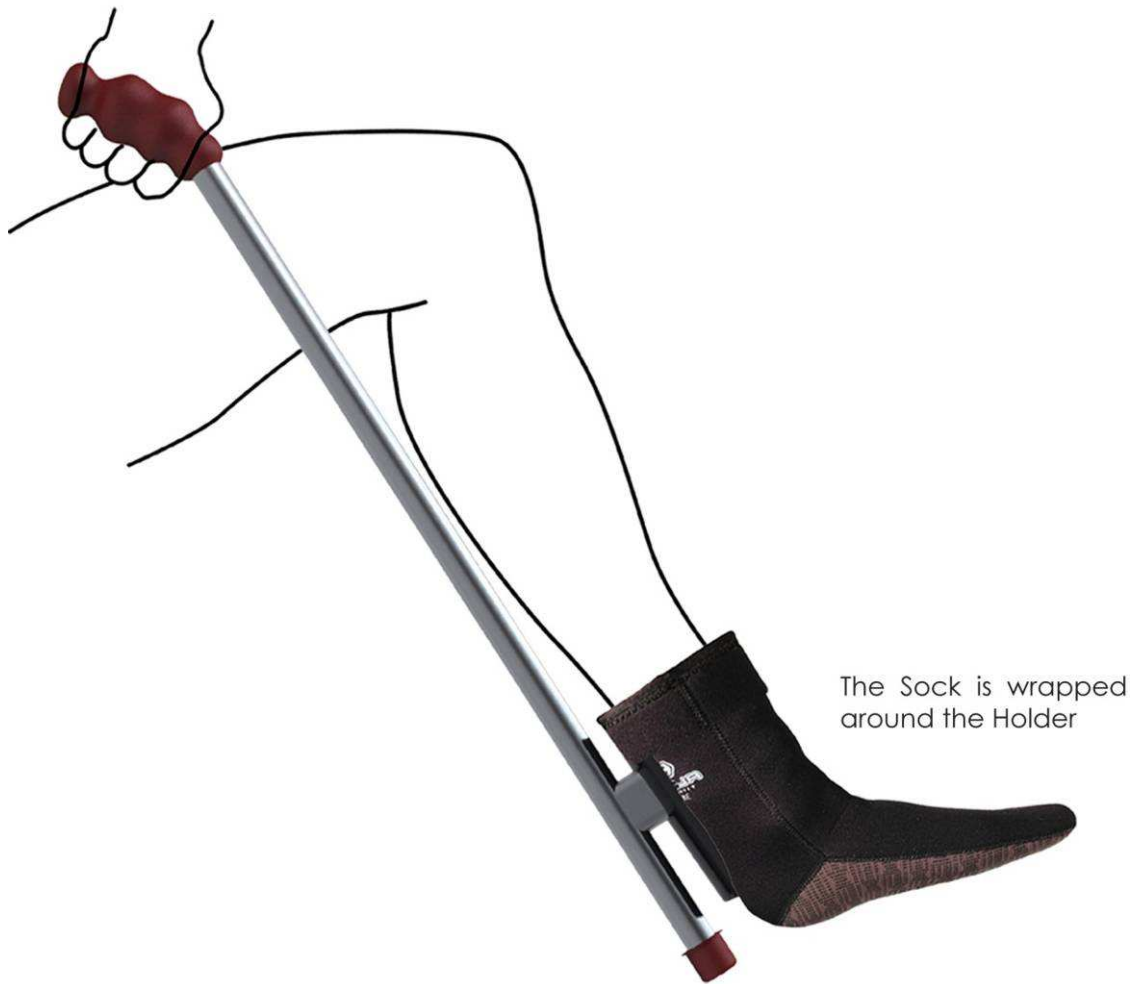

Status of Design Developed: CAD model designed

Suggestion: Prototype needs to be developed for field trails.



Title: COMFORT SHOES for ELDERLY

Name of the Designer & Address: C Gogoi

Problem Perceived:

Problem in walking with comfort, putting shoes on and off, tightening the shoes.

Solution Provided:

Easy to Put ON & OFF, Secured Nature of Locking & Fastening, Non-Skid Tread Configuration

CAD Model, Picture / Drawing:

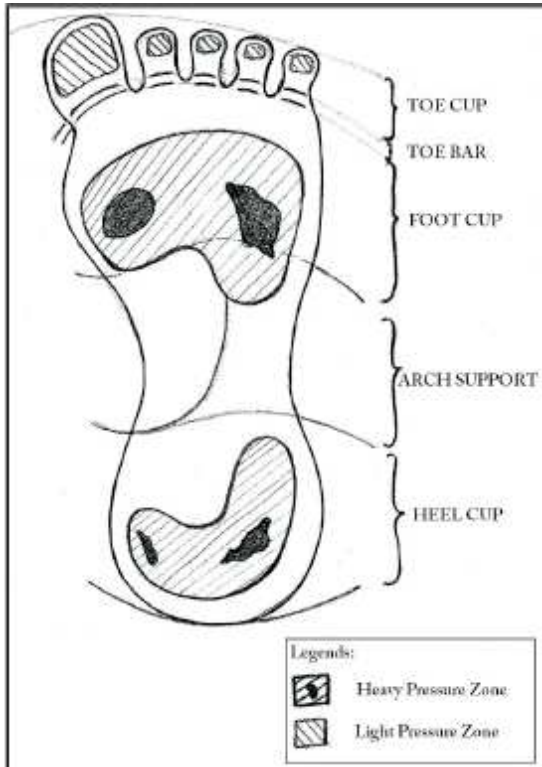

Fig. 2



Fig. 3



Status of Design Developed:

CAD model developed

Suggestion:

Prototype needs to be developed



Title: Assistive device for Stroke Patient

Name of the Designer & Address: Pawan Sonkar

Problem Perceived:

Assisting patients suffering from stroke

Solution Provided:

Assisting Devices for exercising

CAD Model, Picture / Drawing:

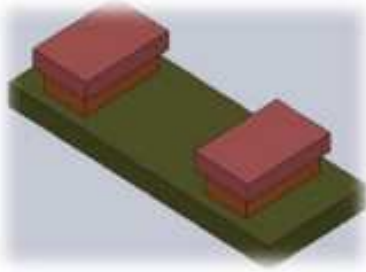

Fig. 6 Sponge

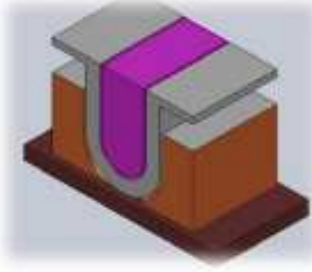

Fig. 7 U Tube

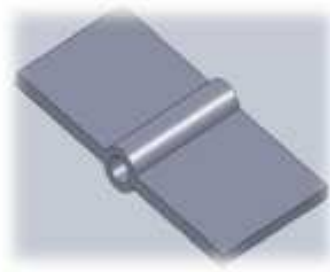

Fig. 8 Flip Flop

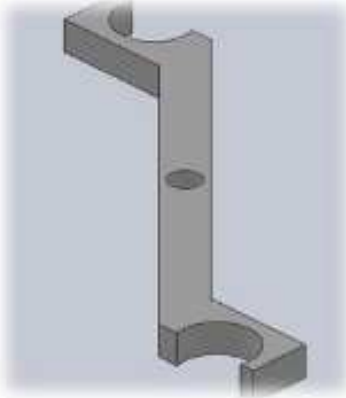

Fig. 9 Z Reciprocal

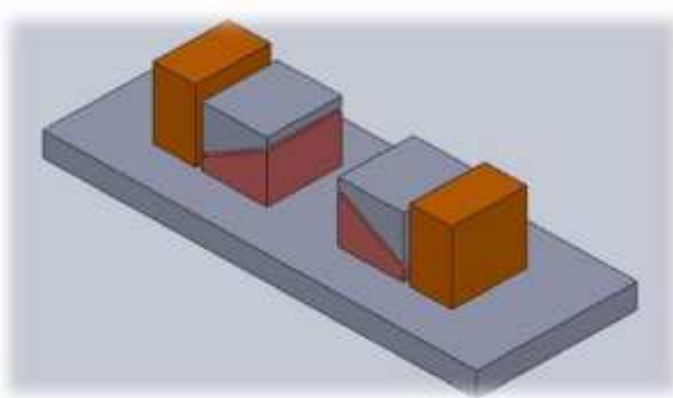

Fig. 10 Wedge

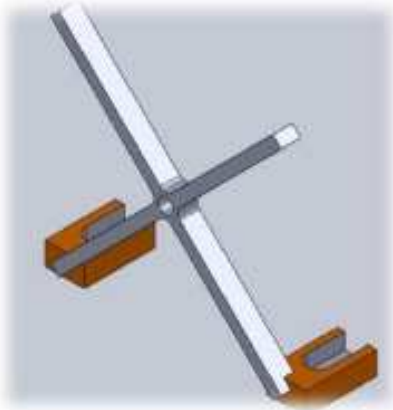

Fig. 11 X lever



Fig. 12 See Saw Config. A



Fig. 13 See Saw Config. B



Fig. 14 Wobble Board at Max Hospital



Fig. 15 Wobble Board in Market

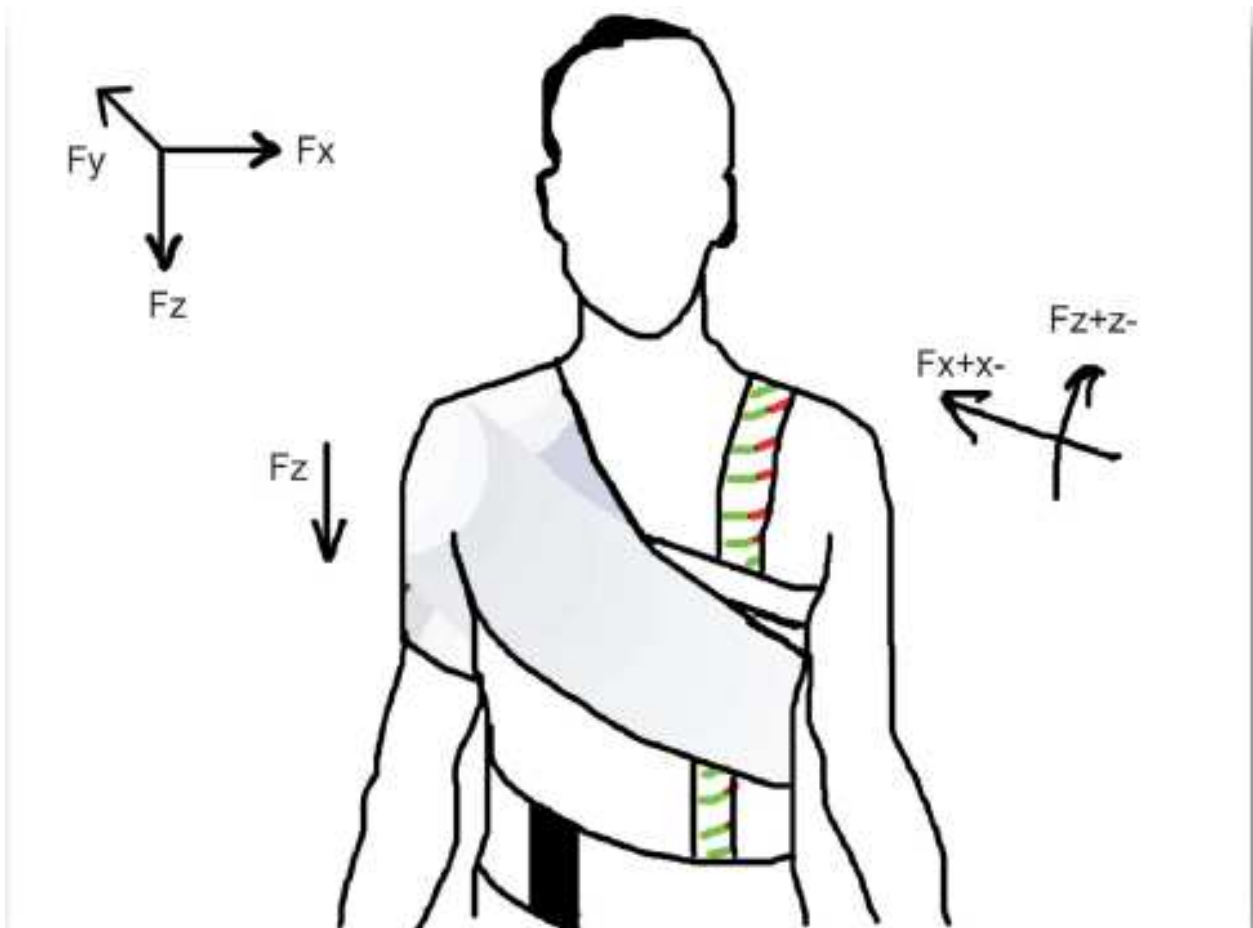

Status of Design Developed:

CAD Model & Prototype Developed

Suggestion:

Prototype needs to be developed for field trails



Title: Staircase climbing walker for elderly

Name of the Designer & Address: Devidutt Gharai

Email : devidutt.mdes@gmail.com

Problem Perceived:

Existing walkers for elderly don't provide the facility of climbing staircases.

And the safety measure is very low in the existing ones

Solution Provided:

Designed boomer mobility aid combines user friendly features in a new and modern form.

A stair ready function, which allows the mobility aid to transform a walker in to a device that enables the user to maneuver stair up and down.

CAD Model, Picture / Drawing



Status of Design Developed

A 3d cad model has been developed with the accurate dimensions ergonomically,

Suggestion

A 1:1 prototype shall be developed, as this is a simple and useful solution for the walkers that exist already in market.



Title: Bathroom for the elderly.

Name of the Designer & Address: Devidutt Gharai

Email: devidutt.mdes@gmail.com

Problem Perceived:

Lack of safety features in common toilets for elderly

The supports and other measures according to their comfort were lacking

Maintenance is needed to get perfect cleanliness and hygiene

Solution Provided:

A single product which specifies the bathroom and toilet area

Product will assist the user in safely using bathroom

Product will aid and stabilize the user giving ample support

The improvement over fixed grab bars helps to increase their mobility in bathroom

Single unit product and can be easily maintained

CAD Model, Picture / Drawing

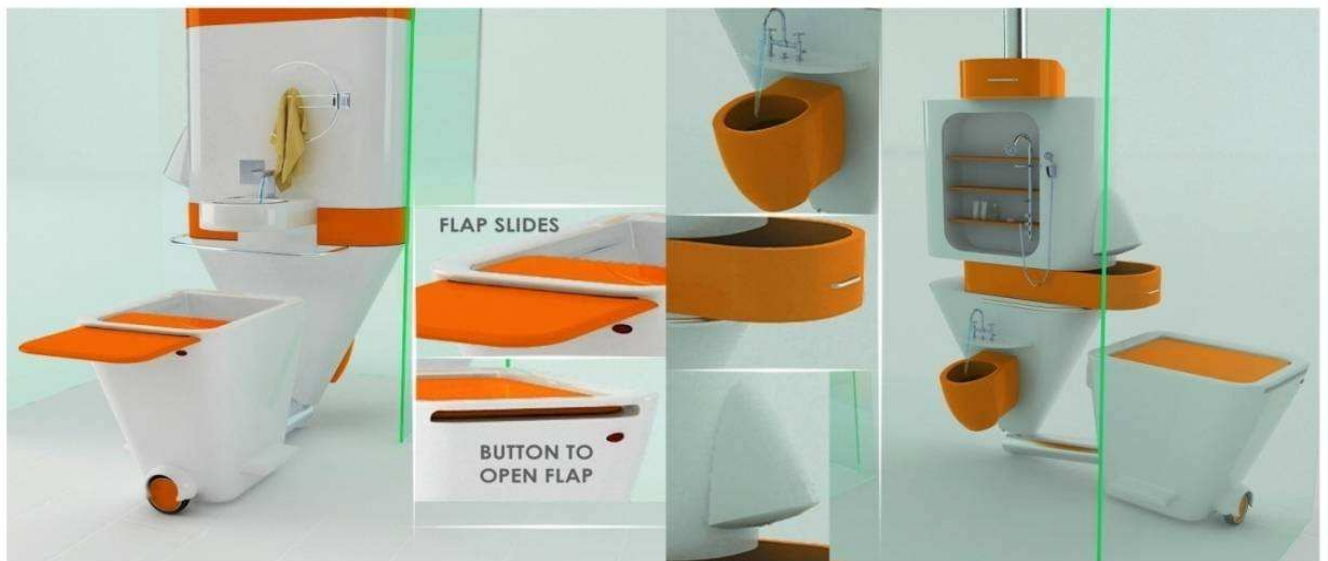

Status of Design Developed

A scaled prototype has been developed along with cad model showing various features.

Suggestion

1:1 scaled prototype shall be developed to experience the product.



Title: Three wheeler ambulance for congested roads

Name of the Designer & Address: Devidutt Gharai

Email: devidutt.mdes@gmail.com

Problem Perceived:

Patients who are elderly or disabled living in high density old city areas cannot get the access of the ambulance because of narrow streets and lanes.

Solution Provided:

- **Auto rickshaw ambulance will be designed to which will be affordable and can be maintained by local residential community members.**
- **It will be cheaper to own and operate compared to all available ambulances in India.**
- **The design is based on auto rickshaw chassis for cost saving and has aluminum exoskeleton.**
- **This gives maximum protection with minimum internal intrusion and also aid the external visual concept of a safe protective environment.**

CAD Model, Picture / Drawing

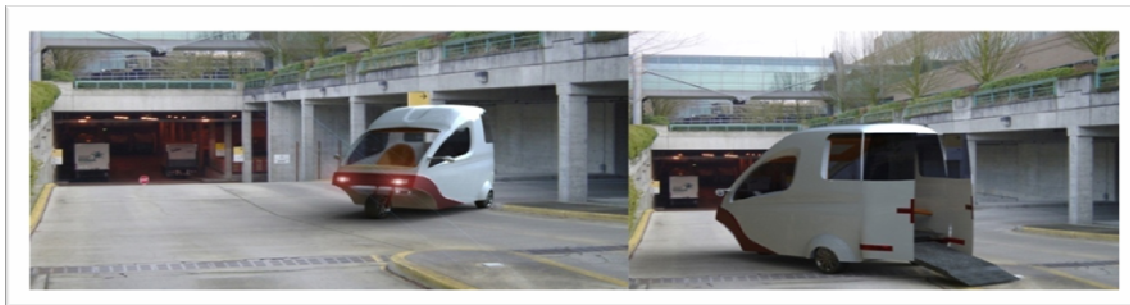

Status of Design Developed

Cad models / drawings and a scaled prototype has been developed.

Suggestion

1:1 prototype shall be made on the existing auto rickshaws doing all the changes in chassis and the skeleton to provide safety.



TRANSX: A bathe support aid

Priyarata Rautray

Mobile - 9999718924

E-mail- priyabrata.rautray@gmail.com

A Thesis Design Project at the Industrial Design Program at the School of Planning & Architecture, New Delhi

The aim of the Thesis Design Project is to conceptualize and develop a product for elderly people that help in safer movement in bathroom and thereby reducing or eliminating the bathroom injuries.

Bathroom Accidents in case of Senior citizens:



The fundamental purpose of bathing is to maintain health and physical well being of the body. While most young, able-bodied people do not think twice about taking bath, bathing is more difficult, more time consuming and more hazardous for older people. Most people tend to look at their bathroom as a retreat away from the world. They never, for one second, consider that this room can be extremely dangerous at times. A recent study showed that one of the single biggest gaps in most home safety plans was the bathroom. Look at the bathroom itself, surrounded by water, slippery tiles and hard ceramic surfaces. These could quite easily cause injury were you to fall against them making it a very dangerous place for senior citizen considering their psychological and physical condition.

Physiologically, bathing allows cleansing of the skin and removal of accumulated foreign matter. Bathing displaces dead

skin, prevents irritations and rashes that would otherwise transform into infections, and washes away waste materials that can interfere with the normal functioning of the skin. Bathing allows people to:

- 1) Maintain acceptable social standards of cleanliness, both appearance and olfactory and*
- 2) Refresh, revive, and relax through the washing process.*

The Magnitude of the Problem Accidental Deaths

Advocates of bathroom safety are astounded by the high incidence of bathing-related deaths. ABT Associates Inc.'s report to the Consumer Product Safety Commission in 1975 indicated that many as 70 persons over the age of 65 die of bathtub-related burn injuries every year. According to the National Safety Council, one person dies everyday from using bathtub/shower in the United States. Of the 24,000 accidental deaths of people over the age of 65 every year, many are bathing related. The National Safety Council reported that 345 people of all ages died in bathtubs in 1989, 364 in 1988, and 348 in 1987. Bathtub related deaths during the three-year period exceeded those due to handgun accidents, all forms of road vehicles accidents (excluding motor vehicles), ladders and scaffolding falls, and ignition of clothing. Because bathtub related deaths occur suddenly and in a supposedly protective environment, these deaths tend to cause a greater degree of psychological trauma for the families

Bathing Injuries

On an average, 370 persons of all ages sustain injuries from bathtub/shower daily in the United States. The dangerous aspect of bathing is evident from the injury data reported by the Consumer Product Safety Commission: 117,230 bathtub/shower injuries in 1989; 136,616 in 1990; and 139,434 in 1991. Those between the ages of 25-64 accounted for 37 percent of all bathtub/shower injuries; the most vulnerable being those closer to the upper age limit. The elderly accounted for 17 percent of bathtub/shower injuries in 1989, 22 percent in 1990, and 20 percent in 1991. More elderly people were injured from using bathtub/shower than from other potentially dangerous equipment such as exercise equipment or cooking appliances (ranges or ovens).

14,000 sudden deaths during bathing a year in Japan

Since the bathroom is a private space, there hardly has been any major research on accidents during bathing. This time with the support of Tokyo Metropolitan Fire Department, based on the result from investigation done from October 1999 to March 2000, cases on sudden death during bathing in Japan were examined. Within 23 districts in Tokyo, there were 628 accidental deaths in 6 months, estimated 866 deaths in a year. With the consideration of age-composition difference in Tokyo and national population, it's calculated to be 14,000 sudden deaths during bathing in Japan in 1999. The number is larger than that of traffic accidents, and in elderly population, is even multiply larger than that of traffic accidents.

Also they were already dead (cardio-pulmonary arrest) at the site in half of the cases. Factors related to sudden death during

bathing were analyzed, and as shown in Table 1, more advanced age, female, colder temperature and reported in the early morning are the characteristics that have tendency with mortality. On the other hand, there were fewer deaths in the cases that were occurred in the early evening. Specific information why more deaths during bathing had seen in female haven't been clear, however the relationship between the time of the accident and mortality has an interesting point in terms of human biological rhythm. Vital rhythms such as body temperature and blood pressure have its rhythm in 24-hour period, and it's known that it has the highest value in the late afternoon or in the early evening and the lowest in the early morning.

Project Brief:

The aim of the Thesis Design Project was to conceptualize and develop a portable device that can help senior citizens to bath safely.

- *The product is specific to bathroom and bathing area.*
- *The product will assist the user in safely using an ordinary bathroom.*
- *The product will aid and stabilize the user giving ample support.*
- *An improvement over the fixed grab bars; help to increase their mobility in bathroom.*

Scope:

To understand the process activities related to bathroom. First examine the safety aspects of bathing. It will then present results of a study that investigated the safety and accessibility needs related to bathing among older people.

Design Scope:

The device should be light and portable. Should provide ample stability as well as give freedom of movement. The device should be optimum in size so that it can be used in any ordinary bathroom. Height should be adjustable and should be cost effective. The width of the device has to accommodate the person while bathing as well as give proper support.

Design Challenge:

The device should such that it inspire user to use it. The device should be compact but sturdy enough. The device should be stylish in the same time not very expensive. Provide adjustable holding and sitting height to different individuals.

Mapping Bathroom Activity

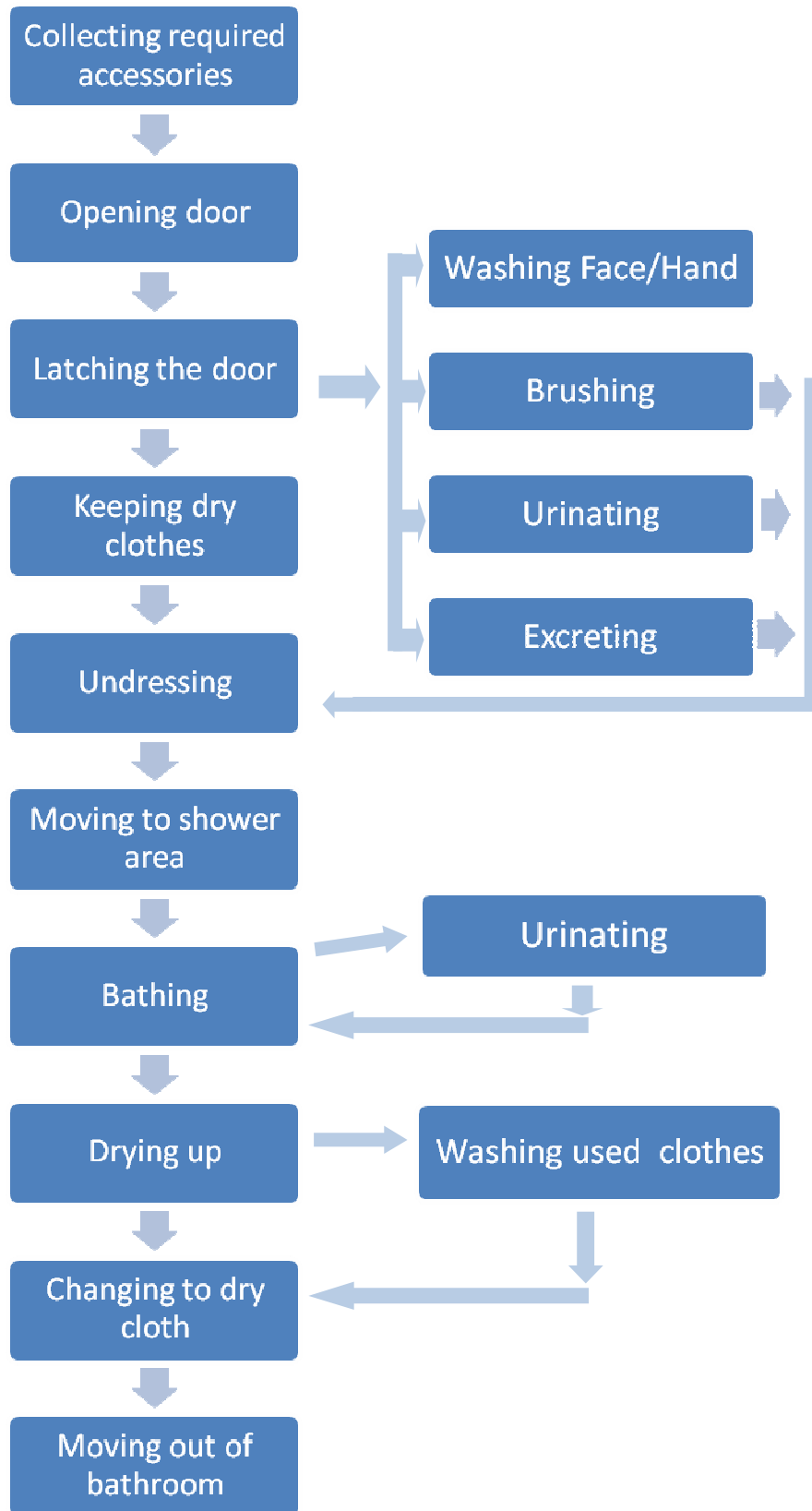

Duration of Bathroom Activity

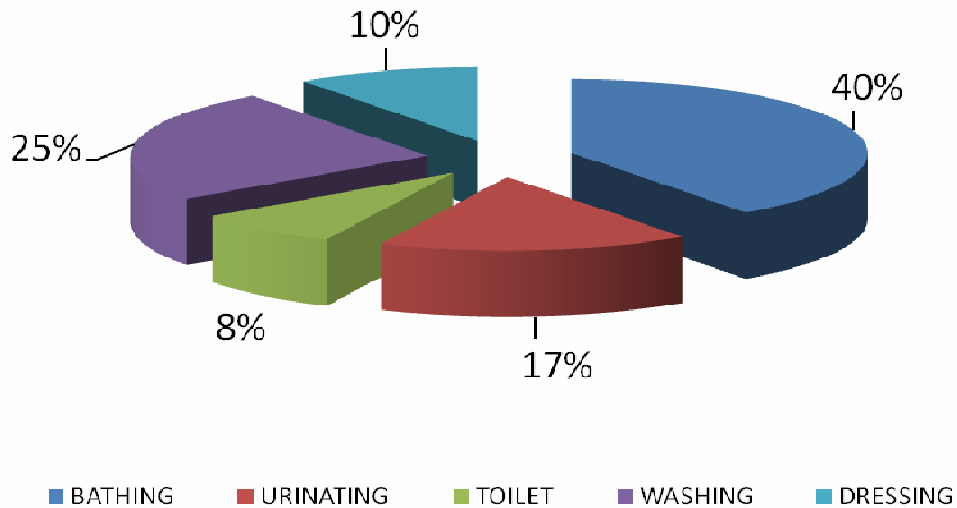

Solution

The solution conceptualized is a cross between a walker and a seat. This will enable an elderly to walk into the bathroom. Sit down in it. Bathe. Get up and go out. The aid will also carry bathing accessory like soap, shampoo, sponge etc. (Not shown here)



Final Prototype:



Status of Design Developed

Two full scale prototypes have been developed along with cad model showing various features.

Suggestion

More prototypes should be made and field trials conducted.



Madhavi Kashiva

Mobile - 9868592018

E-mail- ar.madhavikashiva@gmail.com

Mobil-e: Motorized Wheelchair

Madhavi Kashiva

A Thesis Design Project at the Industrial Design Program at the School of Planning & Architecture, New Delhi. Prototype assistance from DST.

Design Objective:

"The Objective is to Analyze and understand the difficulties faced by wheel chair bound people in going out with their wheelchair for basic necessities and to find a solution which will help them to go out with their wheelchair and have an

independent life of their own. The design will not only consider their physical needs, but also cater their emotional as well psychological needs.”

Scope and Limitations:

The scope can be understood under the following heads:

•*Light weight Safe, affordable, independent, pain free means of mobility.*

•*A person sitting comfortably on it can perform the daily indoor activities like gossiping, reading and writing.*

•*Out of all the disabilities the focus of the project would revolve around the people with spinal cord injury and elderly people.*

CONCEPT GENERATION

TO DESIGN A MOTORISED WHEELCHAIR WHICH GIVE COMFORTABLE SUPPORT TO THOSE USING IT, AND WILL ENHANCE THE ENVIRONMENT IN WHICH IT WILL BE USED

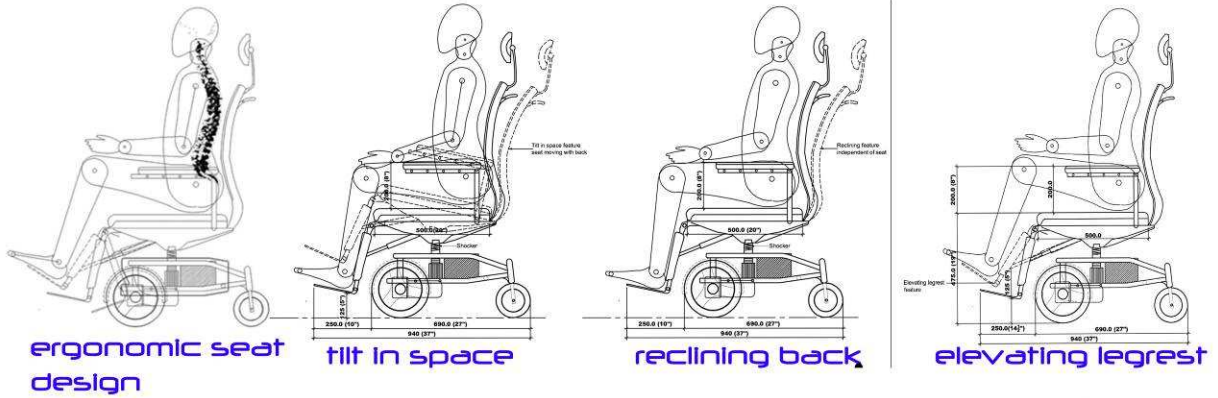

GLASS HOLDER



DESK TRAY DESIGN



POUCH FOR BELONGINGS



JOYSTICK

FINAL PROTOTYPE



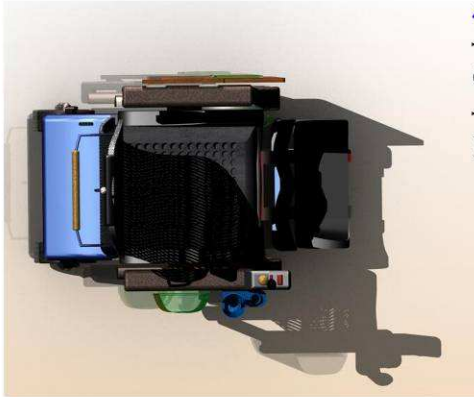

AESTHETICS AND COMFORT

- AIR BREATHABLE MATERIAL FOR BETTER AIR CIRCULATION
- AIR CUSHIONING SEAT FOR MINIMISING PRESSURE SORES

- THE SEAT ALONG WITH THE BACKREST CAN BE TILTED UP TO 10°, TO REDUCE THE PRESSURE ON THE SEATING AREA
- BACKREST INDEPENDENT OF THE SEAT CAN BE RECLINED UP TO 20°



- LEG REST CAN BE ELEVATED
- FULL BACK TILL THE SHOULDER AREA FOR MAXIMUM SUPPORT
- FULL BACK TILL THE SHOULDER AREA FOR MAXIMUM SUPPORT

- STORAGE FOR ACCOMMODATING PERSONAL BELONGINGS WITH VELCRO



SAFETY

- SAFETY SEAT BELTS
- PADDED SAREE GUARD

- SLEEKER JOYSTICK FOR EASY GRIPPING AND ENABLES USER TO MOVE MORE CLOSER TO THE TABLE WHILE HE IS WORKING
- ADJUSTABLE HEIGHT FOR DIFFERENT WORKSTATIONS





Title: Bude'- Design of car for elderly with focus on ingress and egress

Name of the Designer & Address: Dinesh Verma

83 - 4/5, Neeru Verma Apt., Shanti Niwas, Arjun Nagar, New Delhi - 110016

Problem Perceived:

Increased age is associated with:

- **Decline in perceptual ability (i.e., vision and hearing).**
- **Decline in cognitive response time (i.e., motor skills coordination).**
- **Decline in cognitive memory and attention.**
- **Decline in physical strength, and**
- **Decline in dexterity performance.**

Future design and technological adaptations have the potential to extend and strengthen driver confidence and performance in light of physical limitations and age.

Keeping in mind the deterioration of motor skills and growing weakness of the limbs most of the parts can be automated and an automatic transmission system can be used.

The challenge was to design a vehicle, which involves easy ingress and egress, comfort and safety as far as functionality is concerned and 'young and fresh' design as far as aesthetics is concerned.

Solution Provided:

The profile of the vehicle was dependent on the configuration of the wheelbase. Since I was about to conceptualization a three-wheeler I had to fix one the following configurations:

- 1. Front - Two wheels and Back - One wheel**
- 2. Front - One wheel and Back - Two wheel**

I was more inclined towards the first configuration because it is much stable than the second but while sketching I kept it 'an open call'.

While sketching some closed configurations I was constantly faced with the problem of door profiles that came out to be cramped and small.

So I decided to go for a more radical design. I went for a closed configuration that had a bigger door profile for easy

ingress and egress. I wanted to integrate the movement of the door and seat to further simplify access to the vehicle.

Since I had to keep the vehicle simple yet functional I started sketching keeping in mind some of the basic shapes like ellipsoid and sphere.

Finally in the process I came up with the idea of a '*no door concept*'. In this concept I tried using a sphere inside an ellipsoid and vice versa. I idea was when the inner shell will rotate 90 degrees it's 'open profile' will match with the door profile on the outer shell.

The seat can be locked to the inner shell so that it swivels along the shell. Hence a door will be created automatically as the seat swivels.

CAD Model, Picture / Drawing:









Status of Design Developed:

1:10 scale rapid prototype model was made. Currently, we are looking for sponsors to fund the prototyping of a 1:1 scale-working model limited to test purpose.

Suggestion:

1:1 scale prototype can be made for testing purposes. This will ensure that all the safety features, clearances etc. of the vehicle (BUDe) are met (according to Indian standards), before it can be brought on roads.

Title: Ol' Boy - Design of car for elderly with focus on ingress and egress

Name of the Designer & Address: Ringlarei Pamei,
ringopamei@gmail.com

Problem Perceived:

Ingress and egress in vehicles, maneuverability.

Solutions Provided:

- ✓ *Single seat ultra-compact size for short distance city commute.*
- ✓ *Unique door opening design for easy ingress and egress.*
- ✓ *Excellent visibility and easy driving and parking.*

CAD Model, Picture / Drawing:



Ingress simulation



Status of Design Developed:

CAD modeling and one-tenth physical scale model.

Suggestion:

Battery for propulsion and light plastic material can be used for its skin.

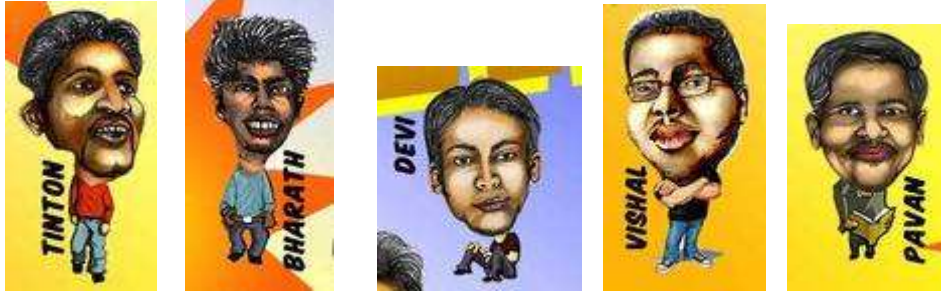

Title: Accessibility Audit at Taj Mahal

Name of the Designer & Address: Tinton Abraham, Bharat J, Devidutt Gharai, Vishal Raj & Pawan Sonkar

Problems Perceived:

Accessibility Audit - IIT Campus

A body-storming exercise was conducted to study the difficulties faced by a person on wheelchair while moving from one place to another. The source point was the Design Studio and the destination was the IIDC Washroom. The following are the major issues that were found by body-storming.



The position of Exit button and door is be opened to the same side.
OPPORTUNITIES:
 Door opening and closing design.
 Position of the biometric device.



Difference in levels of different floors causes jerk while moving.
OPPORTUNITIES:
 Avoiding difference in floor level.
 Giving gradual slope



The ramp for wheelchair is too steep. So moving down or climbing up can be difficult.
OPPORTUNITIES:
 Ramps should maintain the standard dimension of 1:12 or above



Slippery surface while transferring from different levels
OPPORTUNITIES:
 Resucing level difference gradually and providing rough surface for better grip.



Roads having pitioles and stones and gravels.
OPPORTUNITIES:
 Providing Footpaths



The bollards will not allow a person on wheelchair to pass. So footpath is completely not accessible.
OPPORTUNITIES:
 Bollard design to allow pedestrians and wheelchair but not motorbikes



Vehicles parkes in front of the footpath entrance.
OPPORTUNITIES:
 Strict rules should be enforced. Designing the footpath to not allow the vehicles to park anywhere near them.



The ramp for wheelchair is too steep. So moving down or climbing up can be difficult. Assistance is required
OPPORTUNITIES:
 Ramps should maintain the standard dimension of 1:12 or above



Slippery Roads and less space for a person on wheelchair to move if a vehicle passes by
OPPORTUNITIES:
 Availability of accessible foot-paths



Bathroom doors are difficult to reach.
OPPORTUNITIES:
 Better handle designs.



Conjused entrance
OPPORTUNITIES:
 Increasing the width of the door. Double door facility opening to both sides.



Reaching for the wash basin requires the person to lean forward.
OPPORTUNITIES:
 Designing the washbasin to accommodate the wheelchair person to slide beneath it and which allows the person to adjust the height.



Spilling water while washing face due to uncomfortable position of body.
OPPORTUNITIES:
 Adjusting the basin height.



Hands getting dirty and injuries due to rubbing with tyres/wheels
OPPORTUNITIES:
 Seperate hand protection gloves or an extra feature in the wheelchair for the protection.



Accessibility Audit - Taj Mahal

A body-storming exercise was conducted to study the difficulties faced by a person on wheelchair on tourist places. Taj Mahal, Agra was the tourist destination selected for the study.

Members:

Society for Accessible Travel and Hospitality, US

Mr. Scott Rains
Mrs. Jani Nayar

Accessible Barcelona, UK

Mr. Craig Grimes

IIT Delhi

Mr. Amitoj Singh (Professor),

Tinton Abraham

Bharat. J

Debidutt Gharai

M. Vishal Raj

P K Suresh Rao Sonkar



The distance between the adjustable Ramps is difficult to manage.
OPPORTUNITIES:

Folding or Wider Ramps maintaining the slope standards of 1:12 (height:length)



Accessing the switches when there is very little space between bed and wall.
OPPORTUNITIES:

Designing the layout of furniture and the switch positions



The wash basin is too heavy. Difficulty in accessing the lever. Outlet of the basin not insulated.
OPPORTUNITIES:

Change from ceramic to light weight materials
Changing the outlet position so that it doesn't come in contact with body.



The lever used for adjusting the height and position of the support is unable to reach from wheelchair.
OPPORTUNITIES:

Design of support with lever handle in front.



The bathroom is conjoined. The door is open outward.
OPPORTUNITIES:

Doors able to open to both sides. A spacious and fully accessible bathroom



Difficulty in accessing the switch. Height of the table is not suitable for writing.
OPPORTUNITIES:

Better table designs can be incorporated and Better Positioning of switches and controls.



Ambiguity in identifying the swiping side of the card because of symmetry.
wall.
OPPORTUNITIES:

Designing an identification mark on the card which could be felt with hand without seeing.



Difficulty in transferring from wheelchair to the vehicle.
OPPORTUNITIES:

Specially designed vehicles having provision for accommodating the person along with wheelchair



Bumpy ramps increase the effort needed.
OPPORTUNITIES:

Finding an optimum balance between the roughness and ease of moving a wheelchair on the ramps.



No railings for the ramps for support.
OPPORTUNITIES:

Proper positioning of rails on the ramps.



No safety on the edges. The space is not enough for more than one wheelchair to pass.
OPPORTUNITY

Ramps can be extended along with rails on the edges



Too steep and slippery steps
OPPORTUNITIES:

Special arrangement like lift could be provided for the disabled instead of stairs.



Comfort carrier Design lacks 100% utility.
Amateur cannot operate without users manual.
Not fully user friendly.
OPPORTUNITIES:

Design of the comfort carrier can be modified for ease of use.



Difficulty in knowing the correct way to lift a wheelchair if needed to be carried.
OPPORTUNITIES:

Indicating lifting points on the wheelchair.



Wheelchair is too sterile in looks.
OPPORTUNITIES:

Looks could be improved so as to make the disabled feel more comfortable
Increasing the storage space



Bharat J.
2008 JDS 6023
M.Des. IIT Delhi
Computer Science Engr. MACE

CAD Model, Picture / Drawing:



Chairman's Desk:



Dr. Sunil Bhatia

Corruption is lubricant of the machinery of progress of the society. If lubricants are in permissible limit it helps the society to progress in quicker way without creating disturbance to existing system. If it is more than the required limit it spoils the show. Corruption is a universal phenomena and no civilization has ever been spared from its effects. Initially it might be in different from what we see presently with universal appeal, attracts and prospers on universal human weaknesses. It is inbuilt character of entire human civilization. As we progress, it also multiplies and as we reach the level where growth seems stagnant, we experience either rampant or appear corruption has no role in society. Every civilization is facing the heat of the corruption inspite of that every society continues to progress. We should take care that it should not cross the permissible limits. Corruption will remain as long we are alive and it will stay after our deaths. We will pass on what we have inherited to our future generations. We should devise some design for exerting small efforts in direction of reducing the widespread presence of corruptions. It will be a real gift of our sincere efforts to coming generations.

Our country is no exception and as usual corruption is prevailing in each and every walk of life. We are also facing what is natural for progress. Why I say it is natural because it is inbuilt character of human being and our ancestors had also designed to only control the natural human weaknesses of temptation of corruption by using moral, ethical, social, legal and above all religious weapons but they succeeded in just curtailing but had failed measurably in wiping it out from the society. Survival instinct of corruption is amazing. It changes its color and shape so quickly that time can never catch its pace. Introduction of technology has succeeded in reducing some corruption for time being but we should not forget that behind every machine there is human.

A few elite groups in the world are enjoying the benefits of the society and rests are deprived and struggling and sacrificing their lives to make lives worth living for those who and are reaping benefits of the system. Elite experience different levels of corruption. They think big so their corruption is big. Deprived people just think for struggle of their survival, so they face or indulge in lower level of corruption. These suffering classes of people are prevailing in every nook and corner of the world but they never lose their temperament and focus on controlling limited areas of corruption since it is are affecting them directly. Ordinary peoples collective sense is better and they believe that the reason of their miserable lives is not because of corruption rather it is the faulty system and a few who are at the helm of affairs are real culprits at planning or implementation stage. They think they must unite and teach

lessons to those who are responsible for their miserable state. They agitate, call for strikes & bandhs, and paralyze the system. They believe if they do not act collectively and timely, their status will get worst. In India, people are indifferent and just surrender to their fate as if miserable living is their destiny. They believe if we replace these corrupt people by revolution or mass movement 'would new regime achieve their objectives?' They live with serious doubts because they have long history of betrayal "Would they throw up better people?" Their answers comes in negation and think there is no point in revolution and their state will be worst compare to present regime and they do not indulge in such action. But exceptions can not be ruled out and a few local people form small local groups and collectively attack the system with their mightiest force and struggle hard to replace the prevailing cartel of corrupt people. Some time they succeed but generally they are biggest losers and even lose their lives and die as unsung, unnoticed heroes. Those who are onlookers and do not participate in any social mass activities they are busy in running down others by criticizing 'these ruling class is crook , resourceful and smart. Agitation will not invite any change and will encourage another bunch of refined crooks. It is warning and from our past long experience we can foretell about this action, it will not solve their problems rather it will add new problems.' I am not discouraging or running down their fighting spirit against those a few persons who are responsible for miserable condition of majority and enjoying benefits of the authority and are earning by arm-twisting the ordinary citizens. Ruling class either unnecessarily harasses the ordinary people

to meet their malafide intentions by delaying tactics or enjoy their ignorance or forces them to grease their palm for their rightful works. I am always admirer of such groups who are working to correct the system what they think is the best. The best part of the democracy is, it struggles and corrects in its own way. At times a few local people realize where the mistake lies in the system and they agitate for corrective measures and sometime they succeed. Their success stories create ripple effects and affect all. Democracy never entertains forceful changes and never adopts the shortcut to correct its mistakes. It moves in its natural way and it appears very slow but it grinds for better. Democracy always appears struggling for establishing and other systems give illusion as they are perfect and there is no scope for betterment. That is the reason democracy is surviving longer inspite of various short comes and lacuna as compared to so call other man made systems.

Our country is yet to see the true form of democracy; it is still struggling for rooting it in the minds of the people. In democracy everyone should respect one another and disrespect has no place in the system. Ordinary people at grass roots level enjoy momentary respects from ruling class say till their casting of votes and afterwards face humiliation, disrespect from governing people. We have a long history of Hartals, Satyagrahs and other non violence methods to shake the authority if it turns out habit of disrespecting everyone. I call Dharmkund : it means everyone whosoever is responsible and associated with our problems have forgotten their duties towards citizens and they force them to assemble in where

they have encircled the another official as ransom by sitting on dharna in front of official place till concerned authority reaches to some logical conclusion. Mahtama Gandhi used this tool to optimal capacity and forced the Britishers to leave our country. In April 1919, he organized a National "Hartal" or mass strike against the British authorities and it was the first major blow to the British Raj and they tasted the real impact of unity and felt helpless because everything was planned within the preview of law and right of citizen. He again fasted for three days in penance for violence from Hindu activists, but unfortunately the Hartal partly set the stage for the infamous Amritsar massacre. Extracting salt from the sea, then bypassing the tax, was the another act of non violent civil disobedience and it was nothing but a new form of collective power & sign of mass strike.

When I was a small child my father used to tell me about the person who was responsible for rediscovering the lost & forgotten practice of non violence method with very high praise about 'Hartal King' and 'Gherao Minister' from Calcutta Mr. Subodh Banarjee. He was an Indian politician, belonging to the Socialist Unity Center of India. He introduced the Gherao (meaning "encirclement," is a word originally from Bengali, and is a typically South Asian way of protest. Usually, a group of people would surround a politician or a government building until their demands are met, or answers given principle as a formal mode of protest in the trade union sector of India). Hartal is known in local language where employees do not report for duties and a few organizations also join hands as

sympathizers for their cause and do not report for their duties. This way they create pressure on ruling government and draw their attentions for their cause. It was very popular in twentieth century of 70's decade in west Bengal and another part of India. He used to ghearo the officials and never allows them to go out of their official chamber even for quenching and urinating. They force the officials to call the entire concern persons from other departments who are associated with our demands and take appropriate decisions in front of us in this chamber. It was an act under the Dharmkund: A vessel or pot where concerned officials assemble for performing their duties. Otherwise we are free to take any extreme step. It was the way they formed the local government in his chamber. Hartal: An Instrument of Tit-for-Tat Politics or Dharmkund? At the beginning it was simple Dharmkund reminder to officials who are not performing their duties but slowly people used these tools to meet their selfish ends for grabbing the power from ruling by organizing mass strike for evicting them forcefully prematurely. They used money, muscle powers and create manmade artificial situations and forced the authority to congregate for meeting their coveted agenda. How else would they use steps on the ladder of power? Hartal. This mass strike throws up leaders who are not charismatic. Once they acquire the status of elite class they forget those issues that made them heroes and to retain their top position they manipulate and behave as elite class does. Pondering leaders could not assert the principle of 'check& balances'

Different methods are popular throughout the world or correcting the system. 'Bossnapping' is popular in France and it is a form of lock-in where employees detain management in the workplace, often in protest against lay-offs and redundancies. A lockout is a work stoppage in which an employer prevents employees from working. Strike- employees refuse to work. The term *lock-in* refers to the practice of physically preventing workers from leaving a workplace. In all judicial systems this is illegal but is rarely reported, especially in some developing countries. More recently, lock-ins have been carried out by employees against management, which have been labeled 'bossnapping' by the mainstream media. Picketing is a form of protest in which people (called picketers) congregate outside a place of work or location where an event is taking place. Often, this is done in an attempt to dissuade others from going in ("crossing the picket line"), but it can also be done to draw public attention to a cause. Picketers normally endeavor to be non-violent. It can have a number of aims, but is generally to put right pressure on the party targeted to meet particular demands. Picketing is a common tactic used by trade unions during strikes, who will try to prevent dissident members of the union, members of other unions and ununionised workers from working. Those who cross the picket line and work despite the strike are known pejoratively as scabs. Bandh, originally meaning 'closed', is a form of protest used by political activists in some countries like India and Nepal. During a Bandh, a political party or a community declares a general strike. My intention is to give reference about how the rest of the world is practicing for correcting the system. Everywhere

people appear happy but how they are disgusted with the present system is understood by degree of mass strike. Either the system is rotten or not meeting the changing requirements, forces the affected peoples to take such extreme steps for attracting the authority. Those who are suffering keep inventing new methods of mass agitation mostly for their immediate requirements that are affecting their survival. Every agitators has some good intentions is to correct the systems wherever the fault lies. It is always opposed by those who are reaping the benefits or fear of change will bring economical, social loss to them.

With the advent of globalization these tactics seem irrelevant & nowhere valid. When I heard the 'pink sari gang' of illiterate women of remotest & poorest area of North India are challenging the local corrupt government officials who are either not performing what they are supposed to do or busy in corrupt practices. In India, group of women are leading the hope for fighting injustice and regiving dignity to the untouchables. They wear pink saris and go after corrupt officials and boorish men with sticks and axes. The several hundred vigilant women of India's northern Uttar Pradesh state's Banda area proudly call themselves the "gulabi gang" (pink gang), striking fear in the hearts of wrongdoers and earning the grudging respect of officials. Two years after they gave themselves a name and an attire, the women in pink have thrashed men who have abandoned or beaten their wives and unearthed corruption in the distribution of grain to the poor. This group is but a mean of information about these

amazing women who are truly changing India. Seldom they practice non violent techniques, otherwise they follow violent methods and create pressure to that level that concern officials mentally exhaust and act what law permits. The intensity of their violentnesses is reasonable. Our social designers should consider the degree of violentness of their actions in details and help women folk of south Asia to awaken.

Maximization of profits is not unlawful in any religion of the world and no holy books have ever touched this area. They have left this issue to individual's consciousness. Those who are investing money on venture, they think for optimum profits and laborers believe, it is, who are generating profits should be benefited more. This is bone of contentions and it invites strikes, call for bandh, lock-in, lock out etc. There is no written law or rule to settle these issues amicably. Both are in arm twisting business and whosoever is powerful that ultimately wins in longer runs. Working together is compulsion and it is unnatural activity. It is the selfishness that unites us. One has money and another group is to execute. This tug of war keeps on going from the day of industrial revolution and various models comes to the existence but no model has proved successful in attending all the issues related with relation of employer and employee, government with private partners and government officials with public. The longest serving model till today is capitalism. The world's largest economy is currently facing severe recession because they have free enterprise model and in this they have government – private business model for maximizing the profits. The real problem is when

anyone wishes to take away largest share and not willing to sacrifice a little for bigger cause. It makes their role improper and creates imbalance and may be one of the cause of recession of their economy. Adding fertilizers to exploit of our mother earth is ruining our natural resources but we are blindfolded by mind set of maximization of profits. We must pause and think for what we should do for correcting our centuries old practice of wrongdoing. Adam Smith has described these forces as an "invisible hand of the market" or Hegel has stated "universal permanent capital". What we act is nothing but combination of centuries old practice we have inherited and present knowledge. Our national pride is mixture of primitive and modern nationalism. Movements for nationalist and proto-national identities require fabricated admixtures of fact and fiction, ancient history and modern myth. These have created a local colour and flavour of nationalism. Nationalism and sharing of profits are two sides of human. Every country or tribe can boast of their heritage of the Holy book, divine music and religious scriptures. It is not unusual we need such artificial boosting for uniting them by using such icons, personalities etc. But real character surface when sharing of profits comes. That means local group's problems are local but appeal appears universal. They further said the interests of workers are more down-to-earth and immediate. The emergence of labour as an ideologised "factor of production" in bourgeois economy is having the same boundary with the growth of democracy in the initially developing sectors of global capitalism. The latter process had to contend with and harness the aspirations of the labouring classes to the

programme of capital – whether these were projects of imperial expansion in European countries, or of national independence in their colonies. But the attainment of hegemony over labour always carried a price. Political developments such as adult and women’s suffrage, combination rights and social welfare; and structural changes involving the regulation of working conditions and technical processes all expressed the growing significance of labour in modern society. In this sense it is relevant to pose the question whether capitalist democracy is at all a stable form of political association, the very end of History, or an inherently unstable form, given to authoritarian degeneration unless driven forward by the aspirations of labour. Stated differently, we might consider whether the labour movement is implicitly social-democratic in nature, not in this or that phase of accumulation, nor ideologically as a vehicle of nationalism or Leninism, but historically, as the constantly present and inassimilable object of capitalist exploitation. This is in fact a matter of unique design crisis and it needs proper attention of designers. Unique design needs unique handling in extra ordinary situations. By using strikes, protest they create artificial extra ordinary situations and forced the extra ordinary peoples to solve this extra ordinary problems.

Design Crisis-“an inability to synthesize diverse elements into meaningful products.” In lowest level when designers are designing the product and fail to achieve desired output or during design process he/she feels struck with brain and idea is not striking them freely and not allowing them to think

further. They keep on trying with trial & error technique and sometime they succeed in few experiments and mostly abandon the ideas either for future plan or completely forget. There are various type of design crisis it may be budgetary, hardware, shortage of ideas etc. Every crisis looks miniature when we look at social design. At the social level, there are crises. Sometimes social fabrics are torn because of caste, color, creed etc to meet the vested interest of ruling class. These come to foremost as our political system fails to perform the desired roles. I advocate the theory of 'don't worry' because every problem has some solutions. 'When a person is sufferings with ailments and doctors fail to make him to come back to his usual lifestyle and he is slipping into death and doctors accept the real facts of life that is inevitable. I call 'death is also solution.'

When population is growing and there is growing demand for foods, shelter and clothes and to satisfy the need of all is difficult task of designers when there is acute shortage of social design. Faulty design system only cares for those who are privileged. System's all possible opportunities are at their door steps .Other side majority is deprived and struggling hard to meet their daily basic needs. They survive minute by minute, day by day and year by year and as crisis over they thank 'I am still alive'. When we call 'a beggar has no choice' it means a few select groups are so powerful that majority becomes so helpless that they feel impotent and never dare to revolt against their injustice. They do not know the power of collectivism. They continue to live with mercy of others and

facing all sorts of vagaries. They invent new ways to face the current crisis without challenging them. In cold winter they make bonfire, scorching summer, to protect from heat wave they take shelter under the tree and in heavy rain look for place where they can use some shelter for protection of their lives. They keep on designing for survival. They keep on struggling and society never bothers for their welfare and feels they are no more useful. They feel these peoples are liability. I am admirer of skills of their survival of inventing. The moment they ignore the role of innovations, their lives comes under dark shadow and it put a question mark on their survival. They use survival instinct for creativity for surviving longer. The accepted definition of creativity is production of something original and useful, and that's what's reflected in their tests. There is never one right answer. To be creative requires divergent thinking (generating many unique ideas) and then convergent thinking (combining those ideas into the best result). When they try to solve a problem, they begin by concentrating on obvious facts and familiar solutions, to see if the answer lies there. This is a mostly left-brain stage of attack. If the answer doesn't come, the right and left hemispheres of the brain activate together. Neural networks on the right side scan remote memories that could be vaguely relevant. A wide range of distant information that is normally tuned out becomes available to the left hemisphere, which searches for unseen patterns, alternative meanings, and high-level abstractions. The problems we face now, and in the future, simply demand that we do more than just hope for inspiration to strike. Fortunately, they have never studied in

any schools or have any formal training but their general concepts of day to day living made them perfect in surviving art and develop need base technology . Our designers are formally trained and can perform better but either their minds are too obsessive with commercial gain or our society is not relying on their role .We are ignoring the role of designers in our society who can do a lot for betterment of society but reason unknown to them they are not coming out of box thinking. It's up to us to decide what our profession will be about. We live in a time of great fragility, yet there has never more hope, and designers have never had so much power. What will we choose to share with majority of downtrodden: our style addictions or ideas the world really needs to share? We can change the world. Let me share my passion: let me tell you how. Don't just do good design, do well!"

Having glimpsed such a connection, the left brain must quickly lock in on it before it escapes. The attention system must radically reverse gears, going from defocused attention to extremely focused attention. In a flash, the brain pulls together these disparate shreds of thought and binds them into a new single idea that enters consciousness. This is the "amazing" moment of insight, often followed by a spark of pleasure as the brain recognizes the novelty of what it's come up with. These amazing moments are real dynamo of majority of denied living inspite of such miserable conditions. Designers should not only focus on those designing areas where people who can afford and he will commercially benefited rather they should design for uplifting of millions who can not affords. The millions of

deprived peoples are looking toward our designers with some hope but our current designers are ignoring their social responsibility. 'Have our designers thought about social design?' I am afraid. Whenever we design we think in terms of market forces and to establish as man of sensitivity for social and environmental cause and they do all sort of marketing gimmicks and keep on trumpeting their contribution for social cause till they receive awards. Real facts are their design never reaches to millions of deprived. Anyone has ever designed any such article that can match the acceptance and utility of millions of the world like comb, mirror knife etc?' They were real designers and they have designed that was useful for all and never craved for any recognition and die unnoticed. By using their designed products millions are offering their tribute to unknown heroes. We should pledge on the occasion of our Independence Day of India that we will work for social design for uplifting of deprived. We should not only focus for fulfilling the requirement of elite class and never look for any kind of promotional support for our design. If it is really worth for people, in due course of time it will simply accepted by all. When we look toward institutes for some support our eyes lost their real shine and it reflects merciful eyes. When our eyes look toward millions it shines with some unknown divine power. "Let the divine force should guide us and should not pass what bad we have inherited to our coming generations. We live with ignorance and innocence. We have conquered ignorance by our knowledge but simultaneously we have killed our innocence. To regain our innocence we should look at the eyes of millions those are living every moment with hope that

their days will be like a normal human. These poor people have only fears of losing everything and a few ambitions. They need & support for their upcoming. Our designer's role is significant in uplifting the deprived millions so they should see beyond their survival. Denied millions have never had real freedom in their lives and they trust their half baked social design that they have learned from daily struggle of lives. World designers who are trained with formal training under the experts guidance should join hands for social design for eradicating poverty, education, foods and shelter etc. Designing for denied millions is discovery of our lost innocence"

Happy Independence Day 15th August 2010.

Dr. Sunil Bhatia

Design For All Institute of India

www.designforall.in

dr_subha@yahoo.com

Tel 91-11-27853470(R)

Book Received:



Once the exclusive domain of programmers, code is now being used by a new generation of designers, artists, and architects eager to explore how software can enable innovative ways of generating form and translating ideas. **Form+Code in Design, Art, and Architecture** offers an in-depth look at the use of software in a wide range of creative disciplines. This visually stimulating survey introduces readers to over 250 significant works and undertakings of the past 60 years in the fields of fine and applied art, architecture, industrial design, digital fabrication, visual cinema, photography, typography, interactive media, gaming, artificial intelligence (AI), artificial life (a-life), and graphic design, including data mapping and visualizations, and all forms of new media and expression.

Princeton Architectural Press

ISBN 9781568989372

7 x 8.5 inches (17.8 x 21.6 cm)

Paperback, 176 pages

Appeal:



First International Conference on
Intelligent Interactive Technologies and Multimedia (IITM 2010)
(Co-Sponsored by ACM IIIT Allahabad Professional Chapter)
Organized by Indian Institute of Information Technology Allahabad, India
December 28-30, 2010 Allahabad, India



CALL FOR PAPERS

First International Conference on Intelligent Interactive Technologies and Multimedia (IITM 2010) is being held during December 28-30, 2010 at Indian Institute of Information Technology, Allahabad (www.iiit.ac.in). It is well recognized that new paradigms for human-machine interfaces are being developed which will define the 21st century standards and enable the world to communicate and interact efficiently and effectively.

Authors are invited to submit both research and practice oriented papers in the broad areas of Interactive Technologies and Multimedia, covering topics (but not restricted to) as below:

User-Friendly, Technological & Tools in Interactive systems design
Accessibility and Usability, Interactive Systems Case Studies
Perceptual/ Adaptive/ Multi-Modal/ Multi-Context/ Smart Interfaces
Non-Visual and/Or Non-Computer Interfaces
Speech, Image, Video and/or Multilingual Language Processing
Knowledge-based approaches to User-Interface Design
Prototyping and agent-based paradigms for user interaction
Emergent-based and demonstration-based interfaces
Context-aware Computing
Cultural and Societal Aspects of Interactive systems
User Interface Design and Usability Evaluation Methods
Collaborative Systems
Hardware and Software Environment
Human-Robot Interaction

Intelligent Generation of Multimedia Presentations
e.g. for Learning systems, Health care, Professionals
Self-Organizing and Pattern Recognition
Interaction with Large and Small Displays
Power efficient interaction and expressive interactions
Learning in Interactive systems
User-Centered Systems Design
User and Task Analysis Methods
User Interface Engineering and Applications
Development suited for different devices,
based interaction, hardware, tools and systems
Cognitive Modeling of Users and Prediction of User Behavior
Multimedia Data Mining Techniques
Multimedia Signal Processing
Multimedia Web systems, databases, and retrieval
Visualization Techniques and Animation
Virtual, Augmented Reality and Games
Intelligent Systems for Game playing
Vision of Interactive Systems for the Future

Important Dates

Submission of papers	October 15, 2010
Notification of acceptance	October 20, 2010
Camera-ready manuscripts due	October 30, 2010
Conference Workshop	December 27, 2010
Conference dates	December 28-30, 2010
Early Bird Registration	October 20, 2010

Only original technical papers that show the unpublished original research work and are not already under review by any other conference or journal are invited. It is expected that the same set of authors would submit to more than two papers. The papers must reach the conference organizers within the deadline as above. The conference paper format specifications and templates can be found at: <http://www.iiit.ac.in/~iiitconferences/iiitconferences2010/>. A single desktop of volume of proceedings comprising of accepted papers in all tracks will be published. However, research papers of type A – Short communications (up to 4 pages) and B – Full research papers (up to 8 pages) considered by the reviewers should be published in the digital library of IIIT as conference proceedings of the ACM Chapter at IIIT Allahabad. The paper should be submitted through IITM-2010 submission page (<http://www.iiit.ac.in/~iiitconferences/iiitconferences2010/>) of EasyChair conference management system.

For any further information regarding conference visit <http://www.iiit.ac.in/~iiitconferences/> or email us at iiit@iiit.ac.in.

Conference Chairman

Dr. M. G. Tewari
Director, IIIT

Conference Co-Chairman

Prof. R. C. Tripathi
Dean (R&D), IIIT

Conference Coordinator

Dr. Anupam Agrawal
Associate Prof., IIIT

News:

PRESS NOTE 11TH August 2010

Jago! Senior Citizens, Jago!!

Senior Citizens' National Protest Day 16th August 2010

Senior Citizens to observe 16TH August as BLACK DAY

After 63 years of Independence and democracy experiment there are segments of people who are not treated at par with others, there is injustice and discrimination towards them. One of the most neglected and ignored segment is of Senior Citizens. Elders are not considered as part of mainstream, there is unjust treatment to those who gain 60 years of age, and they are suddenly considered 'Retired', good for nothing. Government and Civil Society are not bothered of this experienced and skill group of people.

For several decades, Governments at the center and in the states have been neglecting the problems of senior citizens. Just look at the plight of elders and gross indifference of our Rulers:

- Out of 10 crores of older persons, 66% go hungry every day; 90% have no social or health security; 37% are lonely and neglected.
- National Policy on Older Persons – Announced in 1999 – Not a single state has fully implemented this policy so far
- Only 3 states out of 35 have effectively implemented the Maintenance and Welfare of Parents and Senior Citizens Act – though three years have passed.
- Indira Gandhi National Old Age Pension Scheme implemented by only a few States
- There is no comprehensive medical or health care for old people even after 60 years

Several sincere and serious attempts to get Governments involved and to listen to our problems and demands have failed. **Should we take it lying down any more?** No, we should make our needs and demands known to public and pressure the Rulers to take notice. Therefore, a **Protest Day**, on an all India basis, will be observed on August 16. Nearly thirty State and National level organizations connected with senior citizens from all over India are taking part in this massive movement.

There will be protest activities in every city, town, district and Panchayat to highlight the indifferent attitude of the Governments to our concerns and to press our following major demands:

- Health insurance for all Senior Citizens without any age related restriction or that due to pre existing health condition.
- Immediate implementation of the Maintenance & Welfare of Parents & Senior Citizens Act all over the Country.
- Cover all BPL inmates of Old Age Homes including the terminally ill under fully subsidized health insurance and pay those eligible the Old Age Pension.
- Truthful and honest implementation of the Indira Gandhi National Old Age Pension Scheme all over the Country and payment of minimum of Rs 500/- pension.
- 50% concession in Railway and State Bus fares for all Senior Citizens.
- Exclusive Ministry and National Commission for Older Persons at the Centre.
- As India is Signatory to UN 'Madrid International Plan of Action on Ageing 2002' we hereby demand to implement/adopt all the principals of Madrid plan in **NPOP** (National Policy of Older Person).
- Uniform Age of 60 yrs

All senior citizens are requested to actively participate in observing the Protest Day to voice our above demands. What have you to do on the Protest Day?

- Wear a black band through out that day
- Write Post card for Protest to President ,Prime minister, MOSJE, CM's ,Municipal corporation of state
- Participate in any rally, procession, walkathon, human chain, signature campaign, public meeting, submission of memorandum to local MP's, MLA's, etc that may be organized by your local Senior Citizens' or Pensioners' Association.

The entire exercise will be peaceful, dignified and devoid of any violence – keeping in line with the expectations of the public from senior citizens. Please contact your local Senior Citizens'/Pensioners' Association and get to know the programme for the Day

We request all stake holders including NGO's, Academicians, Institutions, students and Senior Citizens themselves to come ahead and Protest against the neglect and abuse of Senior Citizens by central and state government.

In Mumbai on 16th August 2010 thousands of Seniors Citizens are going to assemble for Protest Meet at Azda Miadan, near CST station at 2pm to 4pm and submit Memorandum to Chief Minister and Governor for Maharashtra.,

Issued by Joint Action Committee for organizing Senior Citizens National

Protest Day

On behalf of Joint Action Committee, Mumbai:

Dr.S.P.Kinjawadekar, President AISCCON - 9820639773

Vijay Aundhe – Gen Sec. FESCOM – Mumbai - 9969845225

Keshav Samant, Gen Sec, General Insurance Pensioners All India Federation - 9869279034

Sailesh Mishra,(Coordinator, JAC All India Committee)President, Silver Inning Foundation - 9819819145 .

Email: saillesh2000@gmail.com

Encl: List of Maharashtra base organization Supporters

Senior Citizens National Protest Day, Maharashtra Supporting Organization

16th August 2010

1. **AISCCON**
2. **FESCOM**
3. **Silver Inning Foundation**
4. **International Longevity Center - India**
5. **Harmony for Silvers Foundation**
6. **GIC Pensioners Association**
7. **The Family Welfare Agency**
8. **General Insurance Pensioners, All India Federation**
9. **Brihan Mumbai Pensioners Association**
10. **All India Bank Retirees Federation**
11. **Jeevan Adhar Seva Sanstha**
12. **Dignity Foundation**
13. **Help Age India**
14. **Indian Federation of Ageing**
15. **Shree Ramanugrah Trust**
16. **All India Retired Reserve Bank Employee Association**
17. **MTNL Pensioners Workers Associations**
18. **All India Central Government Pensioners Association**
19. **Brihan Mumbai Retired Employees Association**

Program & Events:

1.



Access Tourism New Zealand Conference

October 4, 2010

Auckland University of Technology

Registration now open at

www.nztri.org/

2.



universal design

...a process,
not a standard.

universal design award 2011

universal design consumer favorite 2011



Bitte notieren • *please note:*
Anmeldeschluss: 30. November 2010
Erstmalig auch für studentische Teilnehmer.
*Registration deadline: November 30, 2010
Students are also invited to take part.*
universal design GmbH
Nienburgerstraße 14a
D-30167 Hannover • Germany
www.ud-germany.de

Universal design award 2011 will be opened for your registration till November 30, 2010.

For any questions and suggestions please contact:



Lisa Hirschberg
B.A. productdesign
mail: lh@ud-germany.de
phone number: 0049(0)511-70037987 (Germany)

3.



Am 18. und 19. November wird in der hessischen Landeshauptstadt Wiesbaden der Deutsche Marken- und Designkongress 2010 stattfinden. Unter dem Titel „Adding Value by Design“, im Anlehnung an die Studie "Die Schönheit des Mehrwertes" erörten die Referenten die Bandbreite der Designleistungen, die erheblich zur Steigerung des Markenwertes beitragen.

4.

SUMMER / AUTUMN DESIGNBOOM MART 2010

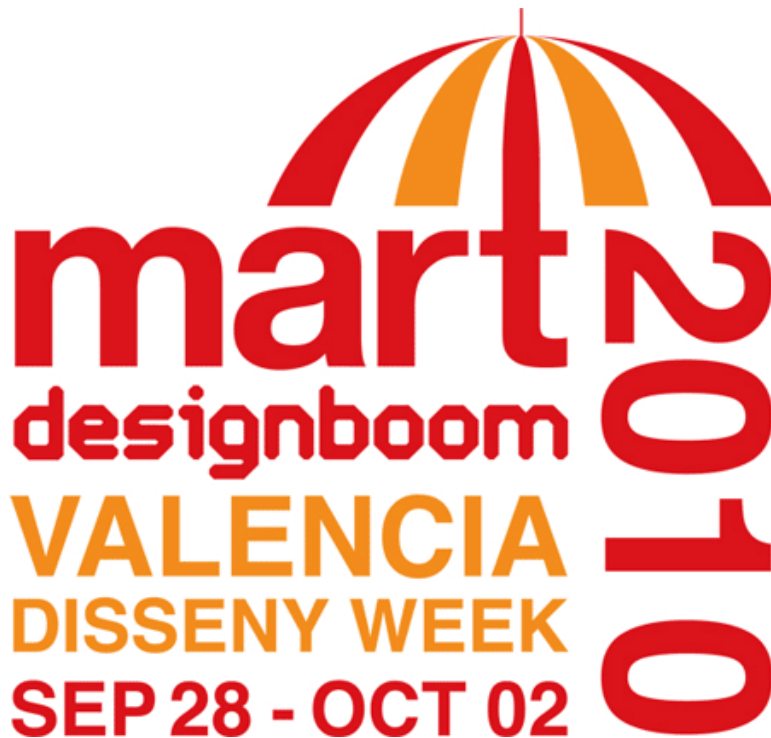



mart **N**
designboom **O**
TOKYO **T**
DESIGNERS WEEK **O**
OCT 29 - NOV 03

5.

OPTIMISM: ICOGRADA DESIGN WEEK BRISBANE 2010
11-17 OCTOBER 2010



REGISTER NOW

Register now to be part of the future of design.

Optimism: to expect the best possible outcome; the belief that good will ultimately triumph

Through the theme of 'Optimism', Icograda Design Week Brisbane 2010 aims to promote dialogue on issues shaping the nature and relevance of communication design practice today. Optimism 2010 will recognise the valuable contribution designers make to delivering benefits and results for business, community and culture. It will showcase businesses that embrace the power of good design to gain a competitive edge. Icograda Design Week Brisbane 2010 will provide a platform for conversation regarding design-led thinking and consciousness for a changing world.

Optimism: Icoграда Design Week Brisbane 2010 aims to inspire, challenge and engage, to provoke thinking and to create change.

Whatever colour, form or function 'Optimism' means to you, join designers and colleagues from around the world in celebration of creativity, communication and collaboration.

Optimism: Icoграда Design Week Brisbane 2010 will coincide with the key initiative of the Queensland Government's [Queensland Design Strategy 2020, Unlimited: Designing for the Asia Pacific](#). Taking place 4 -10 October 2010, [Unlimited:Designing for the Asia Pacific](#) is a new, unique and exciting international design event for the Asia-Pacific region. A diverse program of talks, exhibitions, seminars and workshops, for business leaders, the public, and the design industry, will develop a deeper understanding of the ways in which design is shaping the world around us.

Contemporary Australia abounds with a positive outlook. A powerful optimism lies at the heart of its people and drives the country forward, offering unlimited possibilities.

6.

RKW

[Home](#) | [Aktuelles](#) | [Über uns](#) | [Presse](#) | [Kontakt](#) | [Newsletter](#) | [RSS Feed](#)

BERATUNG WEITERBILDUNG VERANSTALTUNGEN PUBLIKATIONEN ONLINE-ANGEBOTE **PROJEKTE**

erweiterte Suche

Suche

Thema... ▼

Branche... ▼

Status... ▼

Stichwort

Design für Alle

Mit dem demographischen Wandel ändern sich auch die Bedürfnisse der Bevölkerung. Generationengerechte Lebensräume, Produkte und Dienstleistungen werden wichtiger, da sie ein weitestgehend selbstbestimmtes und selbstversorgendes Leben fördern.

DESIGN
FÜR ALLE

Im Zuge des demographischen Wandels stehen gerade mittelständische Unternehmen vor neuen Herausforderungen. Einerseits verringert sich das Angebot an Nachwuchskräften: Die Belegschaften werden insgesamt älter und die Konkurrenz um Fachkräfte zwingt Unternehmen dazu, eine nachhaltige Personalpolitik zu betreiben.

Kontakt

Beate Schlink

☎ 06196 495-3521

@ E-Mail

Events `10

📅 Am 15. September findet in Berlin die Veranstaltung "Tourismus" statt.

Nachfrager von Produkten und Dienstleistungen. So richtet ein wachsender Anteil älterer Kunden mit drohenden oder bereits ausgeprägten körperlichen Einschränkungen den Fokus stärker auf die Funktion und das Handling von Produkten.

Produkte mit hohem technischem Niveau, ansprechendem Design und intuitiver Bedienbarkeit sprechen aber nicht nur ältere Menschen an; sie sind für eine weitaus breitere Käuferschicht attraktiv. Hier bietet sich für Entwickler, Anbieter und Vermarkter ein enormer Wachstumsmarkt.

Das Projekt

"Design für Alle" (DfA) ist ein Konzept, das für eine sich am Menschen orientierende Gestaltung von Lebensräumen, Produkten und Dienstleistungen steht. Ziel ist es, die Lebensqualität der Menschen zu erhöhen, ihre Unabhängigkeit und Selbstbestimmung zu fördern und somit letztlich auch Beschäftigungsfähigkeit zu erhalten. Kennzeichnend für die DfA-Strategie ist, dass die Nutzer bereits in die Entwicklungsphase von entsprechenden Angeboten mit einbezogen werden.

In dem Projekt "Design für Alle" sind von 2009 bis 2012 insgesamt zehn Veranstaltungen geplant (s. a. Gutachten im Auftrag des BMWi). Ziel ist es, mittelständische Unternehmen für die Wachstumschancen zu sensibilisieren, die sich durch die Strategie des "Design für Alle" bieten. Es werden die Vorteile einer regionalen Vernetzung und der Kooperation von Unternehmen, Wissenschaft und Politik aufgezeigt und deren Realisierung vorangetrieben.

Vorgehen im Projekt

Pro Jahr werden jeweils eine Fachtagung auf Bundesebene sowie zwei Veranstaltungen auf regionaler Ebene durchgeführt.

Die Reihe startete am 3.11.2009 mit der Kick-off-Veranstaltung "Design für Alle. Markt der Möglichkeiten für den Mittelstand" in der Region Rhein-Neckar. Hier zeigten das RKW und die Handwerkskammer Mannheim Perspektiven auf, die sich insbesondere für kleine und mittlere Unternehmen durch diesen Gestaltungsansatz ergeben. Erfolgreiche Praxisbeispiele aus dem Mittelstand wurden vrnestellt

🏆 **Wettbewerb: Praxisbeispiele** aus dem Produkt- und Dienstleistungsbereich gesucht, die den Kriterien des DfA entsprechen!
Details und Profilbogen (Bewerbungsschluss: 16.8.)

Wohnen

Veranstaltung "Wohnen heute" am 31. Mai 2010 in Münster.

- 🗣️ [Vorträge der Veranstaltung](#)
- 📄 [Die Übersicht aller Vorträge entnehmen Sie auch dem Programm der Veranstaltung](#)
- 📁 [Dokumentation der Tagung](#)
- 📖 [Literaturempfehlungen zum Thema "Wohnen heute"](#)

Kick-off

- 📄 [Bericht zur Kick-off-Veranstaltung in Mannheim](#)

Job Openings:

1.

Company Profile A leading designer in the Indian fashion industry, synonymous to high-end fashion catering to diverse western and Indian range of clothes.

Job Title

Designer Fashion- Western (Women)

Designer Fashion- Denim (Women)

Lifestyle Accessory i.e bags, belts, jewelry, shoes, etc.

Type of work Design high end women's clothing from conceptualization to prototype, execution and supervision the new range for the season.

Accessory designers must have knowledge of production, market/ fashion trends, sourcing and buying.

Educational background degree in Fashion, from leading fashion institutes like NIFT etc

Years of work experience Two to four years

Location: Marol, Andheri East, Bombay

Please apply with a covering note to dcosta.francis@gmail.com with stating your current salary, expectations and the joining period.

2.

Responsibilities

Create/modify webpages with Web 2.0 technologies/features to best address customer needs

Lead with website best practices and write maintainable, clean HTML/CSS code

Troubleshoot cross-browser compatibility issues to assure our customers get the most trouble-free experience

Express your ideas as you build wireframes to test new layouts and web features

Educate our users better by creating informative icons, diagrams, videos, and other visual elements for the website.

Qualifications

Online portfolio and/or samples " A MUST HAVE

Minimum of 10 pieces accessible via the internet (please be able to provide a URL(s)).

Strong creative and organizational vision for the web, with a good understanding of design and user interaction

• Strong technical skills, including 4+ years experience with:

o Interactive multimedia design, information design, or application interface design

o Standards-compliant CSS/XHTML/PHP

o JavaScript programming experience in frameworks such as AJAX, YUI, JQuery, GWT, or MooTools

o Technical proficiency with Adobe Photoshop and Dreamweaver (CSx)

o Web optimization methods for imagery, video, PDFs, etc.

o Some technical proficiency in Flash

o Some experience with Search Engine Optimization

o Some familiarity with web video, Adobe Illustrator, and Adobe Acrobat Professional

o Some familiarity with Salesforce.com and Eloqua integration into website forms/emails/landing pages

Thorough knowledge of browser compatibility issues for all platforms/major browsers required

Strong graphic design sense

Good writing and verbal skills

Associate or Bachelor's degree preferred from a college/university (no online or distance learning)

A love or aptitude for technology (the Internet, video games, music, etc.)

KEY SUCCESS CRITERIA FOR ASSESSMENT

Experience Candidate needs to meet the requirements listed above regarding experience level and type. Previous design experience with online web properties is mandatory.

Attitude Candidate needs to have shown that s/he can thrive in the fast paced startup environment, someone who has experienced the no pain no gain rule of startups and is excited to commit to an intense environment, someone who can juggle many balls at once competently and with enthusiasm and a sense of humor.

Resourcefulness Candidate needs to show that s/he is adept at creating websites with sometimes only a minimal amount of available resources or direction.

Intelligence Candidate needs to demonstrate the ability to construct logical arguments in a clear, precise, persuasive manner. Candidate also needs to demonstrate that s/he can grasp concepts quickly.

Communication - Candidate needs to demonstrate that s/he can communicate verbally; clear, concise language is used, strong engaging dialogue is presented; and that s/he can demonstrate strong creative, writing and messaging skills.

Flexibility Candidate must be able to turn and burn, prioritizing projects quickly to determine which to complete, pursue, hold. Candidate must also be able to put own ideas aside if another path proves better.

Project Management Candidate must be able to demonstrate ability to operate autonomously and manage multiple simultaneous projects. They must be able to change projects or pace sometimes without much notice as per demands or deadlines.

3.

This is regarding an opportunity that we have UI Designer & Implementer role with one of our clients. This opportunity is based in Bangalore office. The job Description is attached with this mail.

Please let me know if you'd be interested in exploring this opportunity? If yes, it would be great if you can send across your contact number along with your updated profile for our reference.

Kindly let me know if you need any further information.

Note : If anyone from your friend circle is interested please ask them to send their updated resume in word format to me ASAP.

Lead Consultant - Recruitment
Shiksha Infotech Pvt. Ltd.
Contact : +91-9632581947 / 080 - 43340404
darshana@shikshaplanet.com
www.shikshaplanet.com

4.

The VeriSign User Experience team is seeking a passionate and experienced User Interface Designer and Front-End Implementer to create the best user experience for our enterprise and consumer products. In this role, you are a key member of the User Experience team and will participate in the iterative design, rapid prototyping and user testing of our next generation Web-based and mobile applications. You will use your experience in user-centered design and user experience to create innovative solutions for our enterprise applications and consumer products.

Responsibilities:

- **Rapidly prototype concepts and ideas into low and high-fidelity mockups.**
- **Create and translate interaction design and wireframes into visual user interfaces.**
- **Work with other team members to develop prototypes for user testing.**
- **Deliver visual concepts, comps, and other graphical assets.**
- **Translate visual designs into HTML and CSS; work with developers to ensure the user interface is implemented as designed.**
- **Participate in usability testing and user research in collaboration with other members of the User Experience team.**
- **Create wireframes, mock-ups, and UI specifications for our enterprise and consumer based products.**
- **Understand schedules and ensure that milestones are met.**
- **Identify, prioritize, and track usability issues and make design recommendations.**
- **Contribute to design standards, guidelines and usability processes.**

Qualifications:

- **BA/BS in Graphic Design, Industrial Design, Visual Communications, Human Computer Interaction or related field.**
- **7+ years of experience working in Web design, graphics design and/or UI design. Experience designing for mobile devices a plus.**
- **Articulate design concepts and prototypes, with the ability to define your "vision" for the project in a variety of ways - written, visually and verbally.**
- **Mastery of typography, color, and page layout.**
- **Mastery of Web standards, especially Web 2.0, user-centered design principles and knowledge of the software development process.**
- **Thorough understanding of the limitations and appropriate uses of HTML, JavaScript, CSS, AJAX and Flash.**
- **Solid knowledge of Adobe Photoshop, Illustrator and at least working knowledge of Adobe Flash.**
- **Solid knowledge of HTML and CSS; Javascript and Javascript toolkit knowledge a plus.**
- **Strong skills in mediating and resolving competing requirements and designs.**
- **Ability to work on multiple projects simultaneously.**
- **Outstanding presentation and interpersonal communication skills.**

5.

Yahoo is looking for a Creative Lead to join and lead its Custom Brand Experiences (CBE) Group. The position is based out of New Delhi. The CBE functions much like an interactive agency within Yahoo and is tasked with designing custom solutions for big brand advertisers wishing to have a presence on the Yahoo network. Custom brand solutions leverage Yahoo content and technology for building co-branded microsites, games, promotional campaigns and ad applications.

This is a senior position, open for creative folks with 8-10 years of interactive agency experience. User Experience Design professionals with some ad agency experience are also welcome to apply. A formal degree in Graphic Design, Interface Design or Visual Communication is preferred but not mandatory. A solid portfolio is a must, preferably available online for review.

As Creative Lead, you are expected to be very hands on to start with and gradually make a business case and build a team. Expertise with processes, tools and techniques coupled with experience managing small and medium size teams is essential. This position calls for superlative communication and articulation skills since you will work closely with clients and their ad agencies for requirements gathering and doing creative pitches.

This Custom Brand Experience UED team will be part of the larger Emerging markets Design team spread across India, Singapore, Middle East and Latam. The position reports into the Director, User Experience Design (UED) for Emerging Markets.

If this interests you, drop us a line at Join-ued@yahoo-inc.com with your CV and a link to your portfolio. Please enter "Creative Lead + Experience" as your subject

6.

There are openings for graphic designer and furniture designer at HOME CENTRE, DUBAI (Landmark Group).

Founded in 1973 in Bahrain, the Landmark Group has successfully grown into one of the largest and most successful retail organizations in the Middle East. An international, diversified retail conglomerate that encourages entrepreneurship to consistently deliver exceptional value, the Group operates over 900 stores encompassing a retail presence of over 13 million sq. ft. across Middle East, India, Egypt, Turkey, Yemen and Pakistan (franchise operation). The Group employs around 31,000 employees. Landmark Group has a diverse portfolio of retail and hospitality brands, HOME CENTRE being one off them. At over 50 stores spread across the GCC, North Africa, Jordan and the Indian Subcontinent, Home Centre is the leading retailer of furniture and home wares in the region. From its first store in Sharjah, UAE in 1995, Home Centre today occupies half a million sq. ft. of retail space within its stores in the UAE and targeting to take this to 750,000 sq. ft. by opening new stores by end of 2010, and over 2 million sq. ft. of retail space across the Middle East & its markets. Home Centre product range spans furniture, homeware & accessories for the living, bedrooms, dining, Kids, Outdoors & Home Office Segments.

Job profile:

1. GRAPHIC DESIGNER:

Should have good experience in graphic and visual design.
Ability to come up with new looks, themes and concepts for stores
Skills in the area of visual communication, exhibition design and store layouts, shop fittings etc.
Ability to create visual mock ups of merchandise enabling the stores to replicate the same. Good interpersonal skills with ability to interact with different departments

2. FURNITURE DESIGNER:

Should have good experience in furniture design
Strong understanding of processes, materials and finishes
Strong technical skills, knowledge of basic softwares like Photoshop, Adobe illustrator, Coral draw etc as well as 3D modeling softwares
Aesthetic sense enabling to coordinate between the categories
Good interpersonal skills with ability to interact with different departments like marketing, manufacturing/suppliers etc.

Remuneration will be as per industry standards.

Both the above positions are based in Dubai.

Interested candidates can mail their resume' and portfolios directly to Mr. Sitaram Kumar (sitaramkumar@lifestylestores.com)

7.

We require a designer with a work experience of 1 or 2 years in the field of event designs as well as exhibitions. Interested people can mail me their resume here as well as my gmail account. This is an urgent requirement and is based out from Bangalore.

gmail account: puneetsinghdesign@gmail.com

Job Requirement:

-Event Design as well as event management

-Exhibition Design and management

-He or she should have 1 or 2 years of experience in the relevant field.

-Graduate from any design institute are welcomed.

-The job is based out from Bangalore.

8.

Whirlpool Corporation is looking for an Interaction Designer to join its Global Consumer Design team. The position is based out of New Delhi (Gurgaon). Assuming this role, the candidate would be responsible for creating world class consumer experiences for the next generation home appliances. These appliances would be catering to markets like India , China & SEA.

The work environment fosters a culture of curiosity, creativity, problem-solving, and cross-disciplinary collaboration.

Qualification & Background

- Minimum 2 year's industry experience in Interaction Design

- Graduate degree in Interaction Design, Communications Design, or a related discipline preferred

If this interests you & you want to know more, drop me an email at varun.suri@gmail.com with your CV and a link to your portfolio. Please enter "Interaction Designer + Experience" as your subject.

9.

Think Design Collaborative, Hyderabad is looking for full time 3 User Interface Designers to join the User Experience Group. Interested candidates may apply by sending CV and portfolio to rama@thinkdesign.in

All the positions will be based in Hyderabad.

Freelancers (UI Designers and Visual Designers) can also apply for a project.

Requirements:

- **Execute the User Interface design projects successfully.**
- **Ability to convert the requirement into wire-frames.**
- **Creating high and low-fidelity wire-frames, task analysis and work flows.**
- **Good understanding of usability and User centered design principles.**
- **Ability to analyse product, gather user feedback through methodologies like task analysis, usability audit and usability methods.**
- **As a UI designer you will work closely with Visual Designers and if required with development teams to assist with user interface and specifications.**
- **Ability to work independently and in a team.**

Basic skills required:

- **Strong time management, communication and interpersonal skills.**
- **Working knowledge of UI prototyping tools, such as Visio, Photoshop, MS Office and other related tools.**
- **Excellent written and verbal communications.**
- **Bachelors or diploma in Visual Communication or any design related field.**

About Think Design:

Think Design is a Global Research, Design and Innovation consultancy with focus on User Experience Design and Industrial Design. We work across a broad spectrum of industries, including Appliances, Telecommunications, Automobiles, Education, Retail, Software Products, Enterprise & Web Application, Mobile Interfaces and Embedded Applications. Established in 2004, Think Design operates from New Delhi and Hyderabad, with partners across the globe.

Director - User Experience Design

Think Design Collaborative Pvt. Ltd.

**APM Square, Adjacent to Taj Deccan,
Banjara Hills, Hyderabad - 500016.**

M: +91 9849449014

rama@thinkdesign.in

10.

The following positions are based in Hyderabad with an US based software product MNC.

INTERACTION DESIGNER

- **Background in human-computer interaction or related field.**
- **Bachelors or Masters Degree in Interaction Design or related discipline.**
- **Strong experience designing usable, complex web-based interfaces.**
- **Solid understanding of DHTML, scripting, and web technologies**
- **Strong, clean visual design sense.**
- **Excellent leadership, communication and teamwork skills.**
- **Proficiency in process flow diagramming (Omnigraffle or Visio) and wireframing (Omnigraffle, Visio, Fireworks, Illustrator, or Photoshop)**

Web Graphic Designer

- **Online portfolio and/or samples – A MUST HAVE**
- o **Minimum of 10 pieces accessible via the internet (please be able to provide a URL(s)).**
- **Strong creative and organizational vision for the web, with a good understanding of design and user interaction**
- **Strong technical skills, including 4+ years experience with:**
- o **Interactive multimedia design, information design, or application interface**

design

- o **Standards-compliant CSS/XHTML/PHP**
 - o **JavaScript programming experience in frameworks such as AJAX, YUI, JQuery, GWT, or MooTools**
 - o **Technical proficiency with Adobe Photoshop and Dreamweaver (CSx)**
 - o **Web optimization methods for imagery, video, PDFs, etc.**
 - o **Some technical proficiency in Flash**
 - o **Some experience with Search Engine Optimization**
 - o **Some familiarity with web video, Adobe Illustrator, and Adobe Acrobat Professional**
 - o **Some familiarity with Salesforce.com and Eloqua integration into website forms/emails/landing pages**
 - **Thorough knowledge of browser compatibility issues for all platforms/major browsers required**
 - **Strong graphic design sense**
 - **Good writing and verbal skills**
 - **Associate or Bachelor's degree preferred from a college/university (no online or distance learning)**
 - **A love or aptitude for technology (the Internet, video games, music, etc.)**
- User Interface Engineer**

The right candidate will have a proven track-record of Web site development, a passion for usability and interaction design, and the ability to go deep into code to find the right solutions.

- **Bachelor's Degree in related technical discipline.**
- **2+ years experience with Web site and/or software development.**
- **Proven expertise with HTML/CSS and JavaScript.**
- **Experience with Struts, JSP tag libraries and Ajax development a plus.**
- **Understanding of object oriented programming concepts, Java and SQL.**
- **Working knowledge of software development methodology, Web-based programming (server & client), database programming and Web technology (application & Web servers, databases, networks).**

Position location: Hyderabad

Compensation: Highly competitive

Send resumes to reachabhijeet@gmail.com, if interested.

11.

141Wallstreet, the out of home Advertising and Communication design agency, a division of Bates 141 is looking for designers.

Senior Visualiser: Mumbai

The applicants need to have 2-3 years experience in the advertising industry. Be familiar with basic design softwares and be willing to work on them.

Creative Director: Delhi

The applicants need to have 4-5 years experience in the advertising industry. Be familiar with basic design softwares and be willing to work on them.

Please send your resume to Anish Biswas - anish.biswas@bates141.com

12.

Position: Lab Director

Location: Chennai, India

Company: One of the leading market research companies in the world

Job Purpose:

We are looking for a Lab Director to organize and lead the Mobile Innovation Lab in Chennai, India. The position is responsible for Lab's administrative functions, setting the research direction and initiating new projects related to Mobile and Telecom Innovation. The person will work with internal and external customers and stakeholders to ensure that the Lab's strategic objectives are achieved.

Responsibilities:

- Responsible for the efficient and viable running of the Mobile Innovation Lab**
- Actively lead the Lab's research activities in India.**
- To direct focused research efforts toward building India into a pioneer in IP (Intellectual Property) generation .**
- To build and leverage from meaningful relationships with academia as well as the major players in Telecom and IT domains.**
- Work to increase visibility of the company as an Innovator by participating in publications and public talks**
- Work closely with internal and external stakeholders and customers through collaborations**

·Track and monitor latest trends in mobile and wireless technologies to either leverage new opportunities or adapt to disruptive changes with a strong understanding of market dynamics.

·Work pragmatically with product teams to help transfer technology prototypes into the company products.

Qualifications:

· Master's Degree or PhD in Computer Science/Electrical Engineering/ Telecommunications with around 10 to 12 years overall experience out of which at least 4-6 years of industry experience in R&D and innovation.

· Demonstrated ability to generate new ideas and innovate with a proven research track record.

· Technical knowledge in- Mobile and Handset Architecture, Mobile OS, Mobile Server Technologies, Wireless technologies

· Knowledge of Mobile Advertising platforms / Mobile Content Delivery platform, Audience Measurement

· Excellent written, oral, communication and presentation skills

· Good network of India telecom industry and academia

In case you would like to pursue this do write to me on

nidhi.kalra@helix-hr.com

Partner

Helix-HR

Plot # 15,Sant Nagar

East of Kailash

New Delhi-65

Office Ph: 011-46141150 Mob: 9350206956

Email: nidhi.kalra@helix-hr.com

www.helix-hr.com

13.

Role: Lead Innovation Specialist

Location: Bangalore (1st preference), Mumbai or Delhi (2nd preference)

About IMRB Innovation Labs

As part of IMRB – one of India's oldest and largest market research firms, now a part of 'Kantar', the Consumer Insights Division of the multinational conglomerate, WPP (www.wpp.com) – IMRB Innovation Labs was setup in late 2009. With a 40 odd year in-depth experience and foundation of an

established institution like IMRB, yet the openness, freedom and flexibility of a new-born startup, IMRB Innovation Labs is uniquely setup for creating a new paradigm in the area of 'Design Thinking' led Innovation.

This is a specialized practice that works with clients on strategic business problems using 'Design Thinking' as a means to providing breakthrough and transformational results for our clients. These could be in the areas of Product, Service, Process or People Innovation for organizations.

The kinds of client engagements we have been working on include:

- Identifying and defining product and service innovation opportunities for a leading Telecom service provider for the Rural Indian market
- Scenario planning and future envisioning for a multinational technology company that was interested in defining their corporate strategy & roadmap for the year 2016 and beyond
- Identifying product and technology innovation opportunities for a multinational technology R&D Lab for small/micro businesses in the Indian market

Experience: 6-10 years relevant work experience

Skills: Design Ethnography, User Research, Design Thinking

- Proven work experience in the Ethnography / Design Ethnography, Design Research, or Design-led Innovation spaces
- Should have led several engagements with clients in some of these areas:
 - o Product Innovation
 - o Service Innovation / Service Design
- Must have proven experience and competencies in conceptualizing, designing and leading/delivering 'Design Ethnography' engagements. This includes being able to:
 - o Design the right kind of ethnographic interventions / tools based on the business goals and intended project outcomes
 - o Articulate and engage with clients & their stakeholders on the right kind of approach, methodology / tools
 - o Lead a team of Ethnographers, Researchers, Designers, Marketing, Innovation specialists in effectively analyzing and identifying the right kind of insights, opportunities and solutions for the given business goals

o Effectively articulate and engage with clients while presenting and working with the outcomes / recommendations / solutions to the clients and their stakeholders

· Those with solid grounding in any of the Design disciplines (including, but not limited to, Product Design, Communication Design, Interaction Design) will be preferred;

o *Note: This is NOT a rigid requirement, if the right candidate can articulate and clearly establish his/her skills in this type of work, that's also fine. Most importantly, he/she should be able to clearly articulate and demonstrate the value of 'Design Thinking' in addressing business problems*

· Must be obsessive about questioning and relooking at anything & everything; Not for the sake of questioning itself, but for the sake of finding 'transformative' solutions or opportunities

· Must be entrepreneurial in spirit; willing to be a part of a newly setup team that is still in the early days of defining, setting up and establishing itself and its way of working; Must be naturally proactive and be able to take the lead in defining / refining the way we work

14.

We have a multidisciplinary design group based out of Bangalore. We have been Instrumental in providing design solutions at Industrial design and User Experience levels. At Tata Elxsi we have the advantage of working with the world Leaders in various product spaces.

In the domain of Interaction design and User Experience, we have been catering to products and solutions for Next Gen Televisions, Touch Screen Kiosks, Mobile based UI's, Hand-held Media Players, Car Infotainment panels.

We offer the most exciting work environment, and opportunities to work on varied products and platforms.

We are looking for Interaction designers with 2 to 3 years of experience to lead our efforts in this area.

Kind request to mail me your resumes and some snapshots of your work at following address:

aurobindonayak@tataelxsi.co.in

You can alternately reach me on +91-9845514434 or 080-22979118.

15.

A full time Design Director at our Salem, Tamilnadu location.

Essential Functions

The successful candidate is a creative and inspirational thinker with a passion for developing unique and saleable product with the following qualification

To lead a team of 12 artists/designers to guide and execute the direction set by the parent company.

To communicate and understand the requirements of our US office on a daily basis.

Experience

in collaborating hand and digital work such as hand embellishments, hand and machine embroidery, hand painting on silks, Excellent layout and design expertise, along with a strong sense of color for Fashion, home décor and lifestyle products. High trend/style awareness and creative capabilities including strong color sense, pattern merchandising ability, retail and market knowledge.

Proven ability to research color and design trends and then interpret and apply trend knowledge to product.

Qualifications:

Degree or diploma from reputed design schools such as NID/NIFT with Textile/Surface design specialization. minimum of 2 years experience.

Ability to converse in Tamil /Kannada preferred.

Knowledge of design software – Adobe / Nedgraphics / Pointcarre is preferred but not required.

If interested, please send resume and examples of your recent work including salary requirements to info@tana-bana.com

16.

Location: RAMPgreen Technologies, Delhi

Experience: Minimum 2 years

If you are passionate about...

- **Working closely with usability team members, product managers, development teams and other internal stakeholders to build storyboards, proof-of-concept mockups, web interfaces, demos, prototypes of proposed and planned applications and products.**
- **Collaborate in the definition of user interface design standards for applications, to optimize ease-of-use and achieve an integrated and consistent look and feel.**
- **Conducting ongoing research of web-based user interface development best practices.**

And you have...

- **The ability to be a User-Oriented, UI Designer and you can think of ways to make a tool/product more user friendly.**

- More than 2 years of experience in UI designing, with specific expertise with web-based applications and products.
- Knowledge of usability and coding practices for accessibility.
- Demonstrated experience in designing intuitive, user-friendly, and easy-to-navigate web interfaces.
- Fluency with web standards and technologies, including CSS, XHTML, JavaScript, Ajax and cross-browser compatibility.
- Strong web graphics production capability and experience with Photoshop, Dreamweaver, Flash, Visio and other mockup tools.
- Creative approach to problem solving, innovation and issue resolution.
- Superior interpersonal skills and the ability to collaborate actively and proactively with others in a cross-functional team.
- Ability to communicate effectively in writing, verbally and as a presenter.
- Strong attention to detail, and a commitment to delivering highly-polished web-based prototypes under tight time constraints.

Icing on the cake if you...

- Worked on applications like Axure RP
- Graduate/Post- graduate in graphic design, user-interface design, human-computer interaction, or computer science.

...WE WANT TO HEAR FROM YOU!

We are not all Geeky, we want you to:

- Be a fun loving person and a good team player, because it's not just work
- Have the conviction to do the right thing under all circumstances and a commitment to the action

.. Because, at the end of the day we are all human

Rampgreen values Innovation, Collaboration and Integrity. If you have what it takes to be accountable, responsible and above all a child like curiosity to learn, send us your resume now!!

Please send your resumes to vineet.chaudhary@rampgreen.net

17.

Symantec is looking to hire dynamic, talented UX professionals for its UCD team in Pune. We have 5 openings, in (software) user interface design, and

user research/ usability testing, 3 of these are senior positions with 5-7 years experience, the others 1-2 years. We would prefer candidates with experience on software product development, especially in enterprise domain.

You need to have excellent communication skills with an flexible, open minded approach and attitude. A team player who is pleasant to work with, for you will be collaborating with product managers, engineers, visual designers, user researchers, and information developers, across the globe. And yes, you have thorough knowledge and understanding of design process -- UI review, task analysis, design, prototyping, specifying, documenting UIs. And find creative ways to address problems and situations. Skills and experience to design for complex enterprise domain and delivering for emerging technologies such as Silverlight, Flex is a big plus.

Senior UI Designers will be responsible for product UI design, and independently handle design projects. Someone who is a post graduate, or graduate in Industrial Design / Product Design / Software UI Design (SUID) / Information and Digital Design (IDD) / Interaction Design. User researchers with UI design inclination may also apply.

Senior User Researchers will plan, design and conduct user research and usability tests; collect, analyze, interpret user data as well as write and present reports. You will have experience in conducting user research activities like contextual inquiry, usability testing, heuristic evaluation, focus groups and survey design. The best person will be a post graduate/ graduate in Human Factors, HCI, Psychology, or related disciplines, or degree in marketing with qualitative research background. Industrial designers with an inclination for User research are welcome.

Symantec operates in 40 countries with headquarters in Cupertino, California. Its India R&D center at Pune is the largest. Symantec is best known for its consumer and enterprise products like Norton, NetBackup, VCS, Enterprise Vault, Backup Exec, Message Labs etc. 98% of the Fortune500 companies use Symantec products. There are 40+ UCD people working in Symantec at various locations. The team in India is a 20+ group with a mix of UI designers, visual designers and user researchers.

Reply to: nagesh_susarla@symantec.com

18.

Job Requirements:

- **3 plus years of experience with proven ability to lead and direct design styles and efforts for world class software companies. Apple, Microsoft and Google experience will be preferred.**
- **Must be highly proficient with interactive web technologies, software or web applications, and print and branding**
- **Ability to discuss and present an in-depth knowledge of typography is preferred**
- **Knowledge of all the latest web-application technologies, as well as standard HTML, DHTML, CSS, etc**
- **Bachelor's degree in Design, Graphic Design, Fine Arts, or related area required**

Reimbursement: Negotiable

Contact Person: Rakesh Tyagi (Mob no.: 09010168615)

About the company:

MAQ Software is a digital marketing and technology solutions company that helps customers service their markets effectively. We utilize the latest technologies using Cloud Computing architecture, Mobile Platforms, Business Intelligence and SharePoint Server to build great applications. We are based in Redmond with delivery centers in Hyderabad and Mumbai, India.

Visit our website: www.MAQSoftware.com

19.

UI Development director.

A professional having strong development experience in HTML, XHTML, CSS and javascript.

The creativity or the designing is not the major part of the requirement.

Our client is looking for a professional for UI Director role.

They are looking for professionals having more than 9 yrs of strong experience in UI development.

The opportunity is with a leading media digital agency in Mumbai which caters to client in UK, US.

Kindly let us know your opinion & send across your updated resumes at suchita@ehrm.com / priya@ehrm.com

IMPORTANT ANNOUNCEMENT:

We have released a video film of approximately 40 minutes on concept of Universal/ Design For All/ Inclusive Design in the Month of June 2009 and speakers are

Prof Peter Zec of Red Dot, Germany,

Prof Jim Sandhu, U.k

Mr Mike Brucks , ICDRI

Prof Lalit Das, India

Mr John Salmen of Universal Designers & Consultants, Inc. USA

Mr Pete Kercher, Ambassdor EIDD (2nd Volume)

Prof Ricard Duncan, USA,(2nd Volume)

Ms Onny Eiklong, Norweign Design Council(2nd Volume)



Those who are interseted in free DVD kindly write to us along with their postal address or you can download from our website www.designforall.in or download from below links for single clipping .

If you wish to download the film kindly click the below link of your choice

Prof Peter Zec of Red Dot Min -8

<http://www.youtube.com/watch?v=3JML2EbzxDM>

Mr. Mike Brucks of ICDRI Min 1.5

http://www.youtube.com/watch?v=4_7CbkLOkWc

Prof Jim Sandhu, UK Min-8

<http://www.youtube.com/watch?v=Std4PuK4CmM>

Index of the film Min-1.2

<http://www.youtube.com/watch?v=kFyCLPuQgkx>

John Salmen of UD Min-3

Universal Designers & Consultants, Inc

<http://www.youtube.com/watch?v=bU770Vqu19o>

Indian Example of Sari (female dress)

and Dhoti(Male dress) Min-4

http://www.youtube.com/watch?v=_vmAmRUFptE

Mr. Francesc Aragall Min- 5

http://www.youtube.com/watch?v=d-D3JH_JGpA

Welcome note of Design For All

Institute of India Min-1.3

<http://www.youtube.com/watch?v=yqW2vR-3kRg>

We solicit your cooperation and looking for feedback at Dr_subha@yahoo.com



For free Registration: write to
subscribe@designforall.in

Write to us about change of
e-mail address:
address@designforall.in

Advertising:

To advertise in digital Newsletter

advertisement@designforall.in

Acceptance of advertisement does not mean our endorsement of the products or services by the Design for All Institute of India

News and Views:

Regarding new products or events or seminars/conferences /workshops.

News@designforall.in

Feedback:

Readers are requested to express their views about our newsletter to the Editor

Feedback@designforall.in



*Dear Friends,
We need your feedback on our publication and your support for popularizing the concept of our social movement of Design For All/ Universal/ Barrier free/ Inclusive Design. It is our further request kindly submit your latest articles, research findings , news and events with us for publication in our newsletter.*

*With regards
Dr. Sunil Bhatia
Design For All Institute of India
www.designforall.in
dr_subha@yahoo.com
Tel:91-11-27853470(R)*

Forthcoming Events and Programs:

Editor@designforall.in

The views expressed in the signed articles do not necessarily reflect the official views of the Design for All Institute of India.

Chief-Editor:



**Dr .Sunil Kumar Bhatia Faculty Member,
13, Lodhi Institutional Area, Lodhi Road,
New Delhi-110003(INDIA)**

Editor:



**Shri L.K. Das
Former Head Industrial Design Center,
Indian Institute of Technology (Delhi),
India**

Associate Editor:

**Shri. Amitav Bhowmick Industrial
Designer Small Industries Service
Institute. Ministry of Small scale,
Government Of India, Delhi (INDIA)**

Editorial Board:

**Mr. M.L .Dhawan
Mr. Pankaj Sharma
Mr. Pramod Chauhan**

Special Correspondent:

**Ms Nemisha Sharma
Mumbai, India
Nemisha.17@hotmail.com**



Lalit



Pawan



Gogai



Priyavarta



Dinesh



Madhavi

**Address for Correspondence:
13, Lodhi Institutional Area,
Lodhi Road, New Delhi-110 003India.**

**Material appearing in this Newsletter may
be freely reproduced. A copy of the same
and acknowledgement would be
appreciated.**

**This Newsletter is published monthly, by
Design for All Institute of India,
3 Lodhi Institutional Area,
Lodhi Road, New Delhi-110 003 (INDIA)
Tel: +91-11-27853470
E-Mail: newsletter@designforall.in
Website: www.designforall.in**

***(Cover Design: Mr. Lalit Das, IIT-Delhi for
Design For All Institute of India)***