

# Design for All

November 2008 Vol-3 No-11

A publication of Design For All Institute of India





### **Chairman's Desk:**

**During my childhood, I observed that villagers used very old practice to tie the two legs of their domestic animals( Cows, horses, donkeys etc) with rope so that they could not run far away but walk with little difficulty and they left them uncaring in open field for the grazing on the grasses. Some time their owner applied another cruel method of fastening heavy, long enough log that touches the ground as they graze the grass with rope around the animals' necks. When animal wishes to run fast it hits and wounds its rear leg and it restricts their movements. No one was caring for them and as sun is about to set, owner hits them with stick and takes grazing animals back to home. Animals were free to graze in open field of their choice. It was man made torture for animal and owner makes animals artificially challenged.**

**It is well established practice among the bird fanciers in India; they clip few feathers so birds can not fly for long time and not too long distance. They fly for few minutes and ultimately feel tired and find they are not as fast as other normal birds and chances of loosing their life by enemy makes them to surrender to their cage where they feel safe. I call it man made disable birds. Man made them unfit in their lives. Disabled animals are**

**the vulnerable creatures, these are tortured by others living and healthy people.**

**When draught or draft animals are old and lose their physical strength and they are no more useful for transporting, water lifting for irrigation, to extract oil or threshing grains by trampling, either they are sent to slaughter house or they are abandoned . An ox is nothing more than a mature bovine with an education to respond to teamster's signals. To make ox for pulling the cart, villagers castrated males with unhygienic instrument when he is growing to be adult. Sometime they die in this operation if the person is inexperienced. This is not another form of cruelty? Why we are not sensitive enough to look after everyone?**

**Similarly with humans there are organized mafia preparing beggars who are expert in converting the able men and newer with injuries as disabled so they can earn lots of sympathy from normal humans and receive huge alms per day. When in any society, few persons to feed their stomach agreed to embrace permanent disability and use this disability as means for earning of their bread is shameful for all. It shows our sensitivity for others and they are equally culprit that they can go so low for earning few currencies. They are not aware of their precious life.**

**In olden days birth of child was associated with some part of the cosmos and they prepare the cosmic charts to know the affects of different planets on this child. It was very broad thinking for welcoming the new born child. Science has reduced the man as any another animal of the planet and we do not pay**

**much attention in welcoming the new born. Child also thinks as he grows in same manner and bonding between man and man, man with living being is loosing its charms and we are not that sensitive what we were used to be . Cosmos design was producing better psychological person. I am not arguing that this science is perfect or imperfect but it was the better way to welcome the newly born child by associating a biggest gift of the cosmos.**

**Our different governments have introduced many welfare scheme for different levels for different peoples for making them self-reliant by allotting shops, kiosks etc at marginal price or free. Either mafia grabbed those benefits of these schemes or those who got allotment sell their benefits at throw away price to others. They again come back to from where they have started their life and their empty eyes look for another opportunity from government.**

**My question is artificial man made disable persons are outnumbering the disabled with births or accidents. As long we do not control human greed of mafia who takes advantage of our children as well as young men who sell themselves for permanent misery in return they get permanent disability and from they reach to that point in life where there is no return for normal life. We must act and control such thing should not happen to anyone who are able if it continues like that we can not improve life of genuine disable persons.**

**When I look at the challenged person moving within the house or outside, we feel they are different abled person and face difficulty of visiting the place of their choice. Reason is, it is not**

properly accessible. The government in the era of globalization is diminishing welfare measures. We are passing it to private companies. The government has slogan that private companies should fulfil their social obligation of welfare of their countrymen. How can they respond to government call when the life span of companies is declining and life of human is rising? So we should not much expect from these profits oriented companies. It means much responsibility fall on the shoulder of designers. Designers should focus on well being and quality of life, provide for the physical, emotional and spiritual needs of each living being. They should design those products which should be cost effective and easily available.

I am not touching new problems it is well known to the different governments and they have done a lot to make all the possible places accessible. We must understand their limitations and should not doubt their sincerity. It reminds me a story that one cobbler experienced very hot in scorching summer while moving barefooted. He started killing the animals for making the leather for covering the earth. A saint was passing and questioned him. "Why are you killing so many animals?" He answered "this hot summer is horrible for my barefoot. I can not move because it burns my feet. I will cover the entire earth with animals' leather so that I can walk without experiencing burning on my sole."

That sage laughed "Do you know if you kill entire animals of the earth even you can not cover the entire surface of the earth and you will waste your life in doing no good for living being? It is better you make a pair of shoe with animal skin for your foot and move where ever you wish to"

**There are many ways to attack for the solution of the problem. We must look into the solution where minimum wastage of natural resources, less time consuming, simple and apt. We must look into any product simply not the cost of the ingredient but how much energy has been spent to each ingredient of the product and what energy we have spent to create that specific product. It should not be like we have designed and assembled the vehicle and after two years or less discarding and dumping in yard for new model. We must use the same vehicle and should not switch to new vehicle as long it is functional. The reverse approach will always lead to recession in the market. Artificial market dynamism also carries the inflation. Once the growth of the market stagnant, inflation starts mounting and at one point of time it is bound to take over the dynamics of the market. We must go back to our ancient wisdom. Once the grandfather buys the product grand son should be in position to use it. When I was leaving to stay in hostel of my high school, my father advised me two things, one- never borrow single penny under any conditions. This habit of borrowing ruins the peace of mind of a man .Second- never think another person's money is your money. What you have in your pocket is your money and you are authority and no accountable to anyone for taking good or bad decision for that money .I am still following his advice and I feel I am at more peace compared to those who are leading comfortable lives with credits.**

**Similarly our designers should work with those elements available to them for designing the products and borrowed idea**

**should be avoided because it will ruin the designer whatever position, respect he is enjoying presently.**

**While narrating this story of cobbler slaughtering the animals, I wish to attract the attention of the designers that they should design such kits which the challenged person can use with their convenience and make every place accessible. Let the governments of the different world should work in their own way and it needs lots of resources and time to accomplish these next to impossible task to make the world accessible for all.**

**This is first time from the day of our publication of newsletter I have received a article of Mr Bo Beolens on disabled interested in Bird watching. When first time I received the article, I thought it is the first article that is focussing on the disabled birds. I question "Why designers are not designing the product to make the life better of birds, animals and plants. Are they not living beings? When I see the cylindrical iron bar structure to protect the plant from animals both side of the road and plant keep growing and no one remove that protection. Ultimately growth of the plant goes out of the fencing but barbed wire becomes part of stem of the plants. We must use that materials that should have the life less than the secondary growth of the plants and it should dissolve as life span over. When I noticed while visiting the forest, those trees completed their primary growth of attaining the heights were tied with steel wire around the stem of the plant. Out of curiosity, I questioned the forest official, "Why have you fastened this steel wire around these trees stem?"**

**His face became long and was reluctant to reveal but informed 'these forest mafia are tying these wires and we are tired of untying it. They tied at the time of secondary growth of the tree when tree grow around the stem. That this wire prevents the growth of stem from that area and rest stem grows normally. A slight wind is enough to fall these green trees. Cutting of forest is banned. They have designed this technique as naturally trees have fallen. By applying artificial way to make it natural death of the trees for their own small benefits, aren't they playing with life of millions? This is also heinous crime for earning few currencies'.**

**We are advocating for better design for better life for living being. It is new avenue for designers and it will force them to think "We never imagine there is any role of designers for birds, animals and plants. We must act together and save our planets"**

**Earlier bullock cart wheels were huge of 10-12 feet diameter of iron. It was paining for the bullocks because it was huge, heavy and creating lots of resistance for movements. It was government of India who have passed a bill in the parliament that each cart will have tyre and tube wheel of motor with 30lbs air pressure and horizontal weight on the neck of the bullock should not exceed 10 kilograms. This has reduced the cruelty on animals. The role of designers were felt and onward this lots of academic institute of design started focusing on man pulled rickshaw and what we see today is improved design of man peddled rickshaw is the result of bill in the parliaments.**



**When I first time met Dr Scott while he was touring India with SATH to promote and attract the attention of authorities and allied areas persons regarding problems of accessibility, I was amazed to see his level of energy. He personally requested that he wished to give the students of Master of Design of Indian Institute of Technology, Delhi a practical knowledge and took students to one of the world's wonder TAJ MAHAL, Agra, India . Students also found it is the best way to experience the difficulties of challenged person and they can improve a lot while designing anything for challenged person. I proposed him to accept the invitation of one of the guest editor of our forthcoming issue of our monthly newsletter. He smiled and accepted our invitation. When you read this issue you will feel and experience his dedication, sincerity. I feel like to stand and salute him.**

**We believe that the designers of all countries need to step up. Every one has a contribution to make this world accessible. Shouting from the sidelines does not work. And if the technical community does not engage, we will get what we deserve. Everyone should work like Dr Scott. If it happens so, I foresee a better accessible world for all.**

**With regards**

**Dr. Sunil Bhatia**

**Design For All Institute of India**

**[www.designforall.in](http://www.designforall.in)**

**[dr\\_subha@yahoo.com](mailto:dr_subha@yahoo.com)**

**Tel-91-11-27853470®**

## **Forthcoming issues:**

**1.**

**Chairman ICDRI, Mr. Mike Burks has accepted the invitation of our Guest Editor of January 2009 Vol-4, No-1 issue of newsletter. We are honoring the inventor of Braille language for his role in 200 years on 9<sup>th</sup> January 2009**

**2.**

**December 2008 vol-3, No-12 issue is our special invited author's annual issue**

**3**

**Prof Ricardo Gomes of Industry and Design, San Francisco State University has accepted the invitation of Guest Editor and organizing for special issue.**

**4**

**Newly formed organization in Taiwan Asian Universal Design Network has expressed to collaborate with us for special issue and Mr Chang Tang is inviting articles on the behalf of Design For All Institute of India from their members.**

## **Content of November 2008 Vol-3, No-11**

<b>1. Chairman's Desk:.....</b>	<b>2</b>
<b>2. Guest Editor's Desk: Dr. Rain Scott.....</b>	<b>12</b>
<b>3. Creating an Inclusive Travel Product. Challenges in India:.....</b>	<b>18</b>
<b>4. The Waypoint – Backstrom Principles Maritime Inclusive Environments and Practice (Human-Centered Seaworthiness):.....</b>	<b>28</b>
<b>5. Accessible Boating facilities:.....</b>	<b>39</b>
<b>6. Is Delhi ready to accommodate disabled visitors during the Commonwealth Games?.....</b>	<b>61</b>
<b>7. Importance of Anthropometric Research in Developing Regional Accessibility Standards:.....</b>	<b>67</b>
<b>8. Designing a Disabled Friendly Inclusive World Class City Imperatives and Issues for Mumbai:.....</b>	<b>82</b>
<b>9. Designing a inclusive tourist destinations-India:.....</b>	<b>101</b>
<b>10. Overseas Birding with a Disability:.....</b>	<b>114</b>
<b>11. Bodystorming at Taj – Designers Day Out.....</b>	<b>124</b>

**Other regular features**

## **Guest Editorial:**



*Dr Scott Rains*

**Watching an entire subcontinent awaken to its potential is awe inspiring. Seeing India embrace Universal Design as part of its evolution to becoming an economic superpower is deeply satisfying to the disability community around the globe. Influencing the Indian travel and hospitality industry to apply Universal Design to its work, which is what the term “Inclusive Tourism” means at its simplest, has been a privilege. This issue of Design for All India documents that awakening, this evolution, and some of the work by those privileged to contribute. It is the first time a journal of this stature has explored Inclusive Tourism within the boundaries of a single nation and is a hopeful sign for India.**

**Let me first express gratitude to Dr. Sunil Bhatia for his suggestion that we devote an entire issue to the application of Universal Design to tourism in India. To be asked as a non-Indian to edit the first collection of papers on the topic is an honor.**

**Recognition must be given to organizers of a workshop on Inclusive Tourism that traveled through New Delhi, Mumbai.**

**Cochin, and Chennai from August 28 to September 4, 2008. Sponsored by the Ministry of Tourism, with support from Air India and Jet Airlines, this opportunity for travel industry professionals to spend a full day with specialists in Inclusive Tourism was organized by the India Chapter of the American Society of Travel Agents and SATH. The strong turnout by the industry and the effective presentations by local Indian Disabled Peoples' Organizations (DPOs) was the impetus for this issue. We hope it captures some of the excitement of growth in this field and gives exposure to the breadth of initiatives underway.**

**Historically the movement for Inclusive Tourism in India began with the work of Mr. Javed Abidi on the occasion of a visit by physicist Stephen Hawking to India. It is a story that has yet to be documented in print and would make a fine future article for this journal. Together with this issue of Design for All India detailing India's history it would be a valuable supplement to the first chronicling of the growth of Inclusive Tourism worldwide, "Toward a Global History of Inclusive Travel", by Laurel Van Horn M.A. of the Open Doors Organization and by José Isola, President of the Peruvian Polio Society in volume 2, number 2 of the journal *Review of Disability Studies*.**

**As recently as September 2008 India's Ministry of Tourism has affirmed Universal Design in both infrastructure and programs through ads in its *Incredible India!* campaign and by mandating application Inclusive Tourism principles in any project funded by MoT.**

**On a personal note, the dissemination of the Waypoint-Backstrom Principles on human-centered marine design**

through Saroma Holidays, the state of Kerala, and various Kerala houseboat (*kettuvallum*) builders, owners, and operators has been satisfying. In a previous Design for All India article I wrote about the process of cultural appropriation of Universal Design. While Universal Design for Learning (UDL) is the result of professional educators fully embracing, and thus transforming, the Seven Principles of Universal Design, so to the Waypoint-Backstrom Principles (W-BP) are the result of maritime culture accepting the variability of human functionality and ability in the design of boats, jetties, and nautical travel products. Here again India makes for an instructive case study as traditions of hand-crafted kettuvallum hulls, universally designed houseboat cabins, government regulated jetties and shore side accommodations, interface with an Indian cultural treasury including Vaastu Shastri and local mariner practices.

The potential for India to take a leading role in the next stage of the evolution of Universal Design is large. We hope you enjoy this glimpse of where the field is headed in the subcontinent.

**Guest Editor**

**Scott Rains, D. Min.**

**Publisher, The Rolling Rains Report and Tour Watch**

<http://www.RollingRains.com>

## From the Editors Desk



Prof Lalit Das

**A sleeping man hardly has any problems with his disabilities. The traveling women with disabilities, experiences a Pandora box of unexpected of frustrating happenings. Focusing on inclusive travel is the ultimate benchmark for an inclusive, barrier free society. It is our great pleasure that Dr. Rains Scott has currected this issue of Design for All India Newsletter which is increasingly becoming the voice of Design for All / Universal Design Movement around the world. A common platform was long needed. A platform that is free from professional ideological debates and rivalries. Here on this platform, every body has the right and freedom to share their thoughts and contributions. The increasing participation in this effort of Sunil, shows that this is what we needed but never dared to want. This is also the case with the coming of inclusive design, design for all, and universal design based society. What stands in the way is a thin psychological curtain that needs to be lifted.**

**Coming to the present issue it has a collection of original very interesting papers.**

**Soni Somarajan provides travel services for persons with disabilities and explores the potentialities available and how future challenges and changing life styles can even create new disabilities. Bo Beolens explores and shares his own personal experience as a bird watcher going around India. Among other places he visited was Bharatpur bird Sanctuary. I too visited this and was simply awed. On my return I suggested my students to design a pedal vehicle for tourists so that they can easily use binoculars, cameras and recording systems. Here is the result. Unfortunately I did not keep the disabled in mind. A better solution was possible. Sherri Backstrom, Director and co-owner of Waypoint Yacht Charter who is also a certified "Accessible Travel Specialist", writes about how Universal Design principles can be mesh with the challenges of yacht design and the associated rigorous requirements of designing a sea worthy water crafts. It is such application of UD in diverse areas that will actually advance UD. Prof Ms Ketna L Mehta writes about a future Mumbai, which will be disabled friendly. In another paper she speaks of how India can be made into an inclusive tourist Indian destination. Mr. Vikas Sharma talks of the Importance of Anthropometric Research in developing Regional Accessibility Standards. Ms Shivani Gupta writes on how we can make Delhi friendly to disabled visitors during the forthcoming Commonwealth Games.**





**In an earlier issue we had published a student project prototype of a vehicle that is friendly to wheel chair users and drivers. If only we could see this vehicle in production, it would solve many problems of the wheel chair based travellers. With this vehicle you can move at 30 km an hour on roads or at 5 km an hour in your self propelled wheel chair. For the wheel chair users, their wheel chair is like a old man's walking. It must always be with them. The prototype cost was a mere Rs. 70,000/=. That would be about US\$ 1500/=.**



**Happy reading and keep contributing. Let's create a better tomorrow.**

**Lalit Kumar Das**

**[lalitdas@gmail.com](mailto:lalitdas@gmail.com)**



*The author is Vice President - Product Development and E-Commerce at Destination Indus, an inbound holiday company with offices all over India. He is also visiting faculty in Customer Relationship Management at the premier Kerala Institute of Travel and Tourism Studies in Trivandrum. He can be reached at [sonimail@gmail.com](mailto:sonimail@gmail.com)*

## **Creating an Inclusive Travel Product: Challenges in India**

*Mr. Soni Somarajan, India*

**It is not easy being a person with disability and being a travel professional at the same time. I have Limb Girdle Muscular Dystrophy (LGMD) for the last 17 years and I use a wheelchair practically for every activity of mine. Being a travel professional, it has been interesting to note the gradual changes that India has undergone in terms of allowing accessibility in public places, not to mention special facilities being introduced in public transportation as well as support from the Government in terms of travel concessions that work towards providing some economic sense to travel for the disabled.**

**India began its formal tryst with recognizing the needs of people with disabilities (PwD) by the promulgation of [The Persons with Disabilities \(Equal Opportunities, Protection of Rights and Full Participation\) Act, 1995](#) which specifies empowering persons with disabilities and their associates. The endeavor of the Act has been to introduce an instrument for promoting equality and participation of persons with disability on the one hand, and eliminating discriminations of all kinds, on the other. Even after 13 years, this Act has still failed to bring about the necessary metamorphosis in recognizing the fact that PwD are not a special tribe that needs favours but are a recognized part and parcel of India that cannot be left behind in terms of rights.**

## **Being a Travel Consultant with Disability**

**In my field of work, having a disability often comes in my way when I am donning the robe of a travel consultant. There are areas in India which are not even basically accessible for a person like me and that prevents me from having a first-hand experience of a destination. In turn, the destination knowledge component within me which is crucial for being a successful tour consultant lies incomplete. This, albeit for no fault of mine, immediately places me at disadvantage when compared to a non-disabled colleague. Not to mention, a certain accepted mentality within my peers/colleagues regarding my ability/inability to travel which very often comes in the way of my inclusion in trips/official delegations to travel fairs, familiarization trips and exhibitions.**

**Having said that, *my immobility in general has also contributed to a state of greater creativity and thought in my work. Although unfair, we, PwD, are naturally endowed with lesser distractions that immobility guarantees and, therefore, have access to a disproportionate amount of free time to invest in whatever activities we are able to involve in. Consequently, these activities, by virtue of greater attention and involvement, more often do carry a stamp of work meticulously done.* My contributions in the areas of product development and e-commerce are a standing testimony to this and the senior management in my company does recognize this fact. It is both a blessing and curse to realize that they would turn to me to take charge of a situation because I am, more often than not, one of the senior employees who happen to be in station by virtue of the fact that I am not travelling.**

**I do get to travel more these days due to comparatively improved services with airlines and trains. The former is much better equipped to handle PwD while the latter has to go a long way in achieving a semblance of safe and accessible travel. Even though entrances to railways stations have ramps for wheelchairs, the whole thought behind this comes apart in the face of the fact that there is no wheelchair access to railway coaches from the platform and almost nil facilities for inter-platform transfer. Even though the Railways have special coaches for PwD, the purpose is lost when you realize that the wheelchair has to be manually lifted on to the train with the PwD for travel. The level of safety in such measures is appalling and it is with much dread and apprehension that I use these services.**

**Roads in the remote areas with a large tourism potential are still primitive when compared to their well-maintained cousins in the cities and travel on such roads can be bone-crushing experience. In my eagerness to learn more, I have gone through the travails of such travel and have found that the effects of such travel on a PwD is very negative with the constant bumps, gutters and irresponsible driving. This can mean, to a PwD, a whole holiday period being hospitalized due to aggravation of related symptoms or just plain fatigue which is amplified manifold due to the vulnerable nature of one's physical condition.**

### **Product Development for the PwD**

**When the Destination Management Company (DMC) I work for first realized the potential of inclusive travel, they naturally**

**turned to me to assist in the process of product development for this segment of travellers. Being a PwD, they naturally expected a much empathetic approach of product development from my side. The process of development threw up fresh challenges, opportunities, insights and plenty of information in terms of statistics that allowed us to offer a very comprehensive product in this area of travel.**

**The potential that India offers as a tourism product is untold. There is not a country more diverse than India and it is perhaps the best example of a melting pot. The colours, the culture, the history, the people all form a true fabric of patterns that lends itself nicely to the concept of tourism. The destination called India has 'arrived' in terms of tourism and, today, it is considered as a destination that is amongst the finest in the world in terms of the value it offers. In such a scenario, making the destination accessible to the PwD segment was only a natural corollary of the larger process at play in terms of destination development. With the growing numbers of travellers from the PwD segment and the resultant realization of the business potential by the Indian tourism industry, much thought and initiative has gone into development of a suitable product.**

*As a company offering tailor-made boutique holidays, it was imperative for us to create an inclusive travel product that would not compromise on the elements of 'personalization' and 'fantastic value' that we had built a reputation on. And all this had to couple up with the element of understandable cost for the PwD since it is a well-known fact that inclusive travel comes necessarily at a premium cost.*

**Our process of basic development in the first part of this decade involved a re-evaluation of the destinations, which we were already offering, in terms of feasibility for inclusive travel. The initial stages were ones filled with apprehension and disheartening facts as we found out that the destinations, hotels and the connectivity between them were nothing much to write home about for developing inclusive travel. The emphasis then turned to identifying destinations that were most conducive for developing a semblance of infrastructure for this segment of travel. We understood that itineraries, whatever the duration of stay, should not have too much of travelling and, therefore, should consist of lesser number of destinations when compared to the usual itineraries we were creating for our other travellers. This was partly due to the fact that we had to incorporate a decent period of rest at a destination for the PwD before proceeding to another and also keeping in mind that there wasn't a huge repertoire of choice available to us, in terms of destinations or hotels, to build full-blooded itineraries.**

*Another point of evaluation was from the perspective of the PwD – whether each day of the itinerary was able to instil a sense of safe predictability. A PwD is always racked by the sense of unpredictability that a day's events can carry. Our itineraries had to incorporate a significant level of predictability right from the first airport transfer to the last flight out. Everything had to be lent the undercurrent of meticulous planning which conveyed to the client that their state of mind during each day of the itinerary was paramount in ensuring the success of the tour. Empathy plays a large part at this level and*

any DMC building products for PwD have to ensure that they have a decent amount of feedback as well as consultation with travellers from this segment in order to build an error-free tour operation.

The third point was in approaching the identified hotel chains for their support. In this case, we have mixed experiences. *The larger chains with the required economic means supported our initiative by complying with the parameters that we had identified as key for a comfortable stay.* It was easier for them to make modifications in infrastructure like building ramps at all entry/exit points and making the rooms PwD friendly. *Yet, smaller hotels, especially boutique ones, were quite reluctant to incorporate changes because of the simple fear that the basic character of their hotel would be lost.* Even if some did make elementary changes for entry/exit points, the rooms were less conducive for changes which did force many of the PwD to complain. Soiled bed sheets, toilet height, bathroom space were a point of concern for these kinds of hotels and we were forced to take off these hotels off the brochure because of the differences in perception vis-à-vis inclusive travel between them and us. It is an accepted fact that in spite of greater awareness, there is still reluctance on the part of hotel owners in India to open their doors to inclusive travel.

India as a destination has places of interest distributed over considerable geographical distances. Even the famed Golden Triangle (Delhi-Agra-Jaipur) has each of its segments spanning between 200-250 kms. Travel by road over such distances can demand couple of breaks and this also demands adequate availability of refreshment points that are accessible for PwD.



**The quality of vehicles in relation to inclusive travel was pathetic at that point and service providers were not exactly knowledgeable about this aspect of travel. Convincing them was so difficult that transport rates had to be negotiated to their advantage in order to meet the demand from this segment. Educating drivers and chauffeurs about ambient cruising speeds, manoeuvring potholes and bumpy conditions meant virtual back-to-school status and it's worthwhile to emphasize here that re-educating set attitudes and ideas was perhaps the biggest obstacle we faced in our development process.**

**Even though, today, our inclusive travel packages are mostly error-free, the initial days were a mixture of disappointment and great personal anguish. This was partly driven by our passion to do our best for the client and ensuring that they derived great value from our products. When you nurse high standards, anything short of a smile at the end of a day from the PwD was enough to drive us nuts wondering where we had gone wrong. Yet, all this formed the core of the greater learning processes that enabled us, later, to build and operate fantastic itineraries for the PwD.**

### **Future of PwD Travel in India**

**Travel for PwD is only in its infant stages in India and there can only be marked improvement from where it stands right now. *The concept of Universal Design applies not only to developing inclusive infrastructure to enable seamless travel but also to help develop a innate mentality which will form the fulcrum that will accept change according to new forms of disabilities as they come to the fore.* Evolution has to be the central tenet**

**of all concepts related to PwD. It's worthwhile to note that some disabilities of today might cease to be disabilities in the future for e.g. devices that can enable vision for people with visual disability by transporting video images straight to the brain centres responsible for vision. Universal Design becomes encompassing when it includes change in the pattern of disabilities of the future.**

**I increasingly see the use of laptops even at the primary school level, and as I type this, I cannot help but notice the deterioration of dexterity in upper limb digits in children when it comes to using a writing instrument like a pen. We are seeing disuse/misuse of body parts as technology lends automation and ease to our lives and it's wise to note that newer disabilities and syndromes will begin to hold sway as a result of changing lifestyles. It is safe to say that the horizon of disabilities cannot be standardized and should incorporate the dimension of time and change to fairly accommodate the needs of the future for PwD.**

**Travel for PwD in India will largely depend on changing values within the tourism stakeholders community and their acceptance of this segment of travel that needs great thought and creativity. In every sense, companies that believe in the philosophy of tailoring itineraries will find it easier to make this transition to an inclusive travel scenario. An active initiative from the Incredible India campaign by the Indian Government supported by stakeholders within the tourism fraternity and other NGO's can make travel for PwDs within India an easier one. The hotel/transportation industry can play a great role in reducing tariff/fares for companions assisting PwD's so as to**

**bring down costs making travel affordable. Taxes on travel packages for PwD should be rationalized to support the initiative to bring down costs. The relevant trio of Hotel, Transportation industries and the local governing bodies has to form an apex body that will evaluate and form a comprehensive guiding policy and then lay guidelines for the Tourism industry to follow in general. There is a greater underlying benefit for all relevant players to gain from the inclusive travel segment by enabling its smooth existence.**

**The future remains bright even if it means having to go a long way.**

**Soni Somarajan**

**India**



*Sherri Backstrom, Director and co-owner of [Waypoint Yacht Charter Services](#) is the only broker in the industry who is certified as an "Accessible Travel Specialist". With many years of experience as a sailor with a disability she is also a member of the US [Power & Sail Squadron](#) and [ASA-certified](#). Waypoint represents a global fleet including partially and fully accessible boats for charter. One of Ms. Backstrom's primary goals in 2009 is to work with shipbuilders and marinas to improve their designs as she visits as many existing accessible yachts and venues as possible. To inquire about her services or to schedule a stop on her itinerary contact her at: [sherri@waypointcharter.com](mailto:sherri@waypointcharter.com)*

**Waypoint Yacht Charter Services**  
**4648 Lakeway Drive**  
**Bellingham, WA 98229**  
**Email: [contact@waypointcharter.com](mailto:contact@waypointcharter.com)**

# **The Waypoint – Backstrom Principles Maritime Inclusive Environments and Practice (Human-Centered Seaworthiness)**

*Ms .Sherri Backstrom, Director*

*Dr Scott Rains Publisher RollingRains.com*

**Maritime tradition as old as recorded history shapes human experience. As a species born on land yet fascinated with water humans endlessly take to waterways and the sea in ships.**

**Seaworthiness is a measure of the fit between the environment a watercraft must navigate and the ability of humans to use that craft for their own purposes. Universal Design captures this essential dynamic at the core of seaworthiness.**

**Universal (or “Inclusive”) Design is a set of seven principles (see Appendix or <http://www.slideshare.net/srains/universal-design-the-seven-principles> ) created to maintain balance between environmental and human requirements during the design, construction, and use of an environment, a product, or a product-service system. It is:**

*Universal Design is a framework for the design of places, things, information, communication and policy to be usable by the widest range of people operating in the widest range of situations without special or separate design. Most simply, Universal Design is human-centered design of everything with everyone in mind.*

*Universal Design is also called Inclusive Design, Design-for-All and Lifespan Design. It is not a design style but an orientation to any design process that starts with a responsibility to the experience of the user. (Source:*

<http://www.adaptiveenvironments.org/index.php?option=Content&Itemid=3> )

In a time where advances in materials and construction have met with new markets for watercraft, Universal Design has been applied successfully to kayaks, yachts, tenders and cruise line mega-ships – and everything in between. This democratization of boat ownership and the migration of leisure, sport, and luxury activity to a water environment by an ever-widening range of people both reflect and advances contemporary expectations of full social inclusion for people with all ranges of abilities.

Universal Design is a land-based tradition originated by quadriplegic architect Ron Mace and his colleagues during the 1970's. Systematically applied and modified to the maritime environment this design approach began to be known as the Waypoint-Backstrom Principles in the early 2000's through the work of Sherri Backstrom and colleagues gathered around [Waypoint Yacht Charter Services](#).

*The Waypoint-Backstrom Principles assume the application of the principles of Universal Design but the highly changeable nature of water-borne environments brings into even higher relief issues of entry and egress (embarkation and debarkation), intermodal transport, personal safety, and human impact on the natural environment.*

*It is hoped that these principles will continue to shape the maritime tradition toward the day when all people or all ranges of abilities may freely and safely "take to the sea in ships."*

## **Principles**

### **1) Begin with Universal Design**

**The principles of Universal Design are an essential element of seaworthiness. Assumptions of the abilities (physical, mental, or sensory functionality) of crew or passengers as constant over time in any single individual or uniform throughout the population of owners and users of the watercraft throughout its lifespan are to be questioned. Design decisions made on exclusionary assumptions about human users are to be challenged as creating an unseaworthy craft.**

## **2) Design for Self-Sufficiency**

**Watercrafts are the insertion of a terrestrial into a maritime environment. Issues of provisioning, fueling, and waste disposal introduce unique design constraints that require balanced attention to both social sustainability (Universal Design) and environmental sustainability (green design).**

## **3) Design for Extraordinary Conditions**

**Maritime practice traditionally assigns clearly-defined shipboard roles and responsibilities. Design assumptions follow. Assumptions about the abilities (physical, mental, or sensory) of the idealized role-holder as they are designed into products, spaces, and practices may prove to be disastrous in emergency situations. In such cases the only person available to fulfill a lifesaving task may not share the ability set assumed in the design whether that is through temporary injury of the crew, or substitution of a child, elderly person, or person with a permanent disability. Designing for extraordinary conditions is a principle that accepts current evolving definitions of disability as the interaction between ability (functionality) and**

environment (design; social response to variety in human functionality). It “imagines” disability as a normal consequence of life and designs for it proactively.

#### **4) Design for Modularity and Revision**

While a core tenet of Universal Design is that the design be sufficient “without special or separate design” the frequency of maintenance necessary for watercraft, especially in a saltwater environment, leads to frequent opportunities for upgrade to accommodate the range of abilities in crew and passengers. Original ship design that envisions modular upgrading and maintenance protocols that actively query shipboard experience for opportunities to design for improved inclusion are to be encouraged.

#### **5) Design for Seamless Intermodal Transfer**

Sophisticated and efficient systems have been developed to load and unload watercraft, haul them ashore, or transport them. Similar breadth of imagination and technology is often lacking in relation to human passengers. Assumptions that all crew and passengers can safely and independently embark, move freely through, and disembark a vessel are to be examined thoroughly at the design stage and reviewed systematically through the vessel’s operation. Special attention is to be paid to the effect of climactic and environmental conditions, aging, and temporary or permanent disability on the part of crew and passengers. Intermodal transfer by its nature involves more than design of a single vessel. It requires attention to the interface between vessels and docking systems



(fixed or temporary), tenders, and emergency evacuation systems.

The current world standard document on this topic is entitled *Accessible Boating Facilities: A Summary of Accessibility Guidelines for Recreation Facilities* finalized in 2002 and published by the United States Access Board in 2003 with subsequent updates and commentary. (See Appendix)

For further information:

**Sherri Backstrom, Director**

**[sherri@waypointcharter.com](mailto:sherri@waypointcharter.com)**

**Waypoint Yacht Charter Services**

**4648 Lakeway Drive**

**Bellingham, WA 98229**

**Toll Free (US & Canada): (888) 491-2949**

**Office Phone & Fax: (360) 656-5934**

**Email: [contact@waypointcharter.com](mailto:contact@waypointcharter.com)**

*Ms. Sherri Backstrom, Director*

**[sherri@waypointcharter.com](mailto:sherri@waypointcharter.com)**

*Dr. Scott Rains, D. Min.*

*Publisher, The Rolling Rains Report and Tour Watch*

**<http://www.RollingRains.com>**

# Appendices

## Principles of Universal Design

1. *Equitable Use*: The design does not disadvantage or stigmatize any group of users.
2. *Flexibility in Use*: The design accommodates a wide range of individual preferences and abilities.
3. *Simple, Intuitive Use*: Use of the design is easy to understand, regardless of the user's experience, knowledge, language skills, or current concentration level.
4. *Perceptible Information*: The design communicates necessary information effectively to the user, regardless of ambient conditions or the user's sensory abilities.
5. *Tolerance for Error*: The design minimizes hazards and the adverse consequences of accidental or unintended actions.
6. *Low Physical Effort*: The design can be used efficiently and comfortably, and with a minimum of fatigue.
7. *Size and Space for Approach & Use*: Appropriate size and space is provided for approach, reach, manipulation, and use, regardless of the user's body size, posture, or mobility.

*Compiled by advocates of Universal Design in 1997. Participants are listed in alphabetical order: Bettye Rose Connell, Mike Jones, Ron Mace, Jim Mueller, Abir Mullick, Elaine Ostroff, Jon Sanford, Ed Steinfeld, Molly Story, Gregg Vanderheiden. The Principles are copyrighted to the Center for Universal Design, School of Design, State University of North Carolina at Raleigh [USA].*

The Principles established a valuable language for explaining the characteristics of Universal Design. They are in common use around the world, sometimes with slight modifications, primarily one or two principles grouped together. It is expected that the principles will be reconsidered on the occasion of their tenth anniversary in 2007 and are likely to evolve in response to experience with implementation and in order to incorporate insights and perspectives from the engagement of more diverse cultures.

Source:

<http://www.adaptiveenvironments.org/index.php?option=Content&Itemid=25>

## **Sample Information Sheet on Yacht Designed for Passengers with Disabilities**

**All cruise ships have a limited number of accessible cabins and in-room special needs amenities such as TTY phones and vibrating alarm clocks. To obtain the cabin and amenities you require, book early.**

**For complete information about this cruise ship, including a picture, [click here](#).**

**For passengers who are Deaf or Hard of Hearing**

**For passengers with limited mobility**

<b>Wheelchair accessible cabins</b>	<b>Yes</b>
<b>Cabins with widened stateroom door</b>	<b>Yes</b>
<b>Cabins with widened bathroom door</b>	<b>Yes</b>
<b>Cabins with roll-In shower</b>	<b>No</b>
<b>Cabins with fold down shower bench</b>	<b>No</b>
<b>Shower stool upon request</b>	<b>Yes</b>
<b>Number of inside accessible cabins</b>	<b>0</b>
<b>Number of outside accessible cabins</b>	<b>0</b>
<b>Number of veranda accessible cabins</b>	<b>0</b>
<b>Number of suite accessible cabins</b>	<b>1</b>
<b>Push-button cabin door</b>	<b>No</b>
<b>Push-button bathroom door</b>	<b>No</b>
<b>Additional grab bars in bathroom and shower</b>	<b>Yes</b>
<b>Raised toilet seats</b>	<b>Yes</b>
<b>Toilet grab bar</b>	<b>Yes</b>
<b>Transfer bench upon request</b>	<b>Yes</b>
<b>Adjustable shower height</b>	<b>Yes</b>
<b>Closet bars lowered</b>	<b>No</b>
<b>Safe accessible from wheelchair</b>	<b>No</b>
<b>Elevators support wheelchairs</b>	<b>Yes</b>
<b>Elevators support scooters</b>	<b>No</b>
<b>Wheelchair access to all public rooms</b>	<b>No</b>

<b>istive listening devices available on request</b>	<b>No</b>
<b>Infrared system in show area to amplify dialogue</b>	<b>No</b>
<b>TTY phone in stateroom</b>	<b>Yes</b>
<b>Shake awake or flashing light alarm clock on request</b>	<b>No</b>
<b>Flashing light warnings for emergencies</b>	<b>No</b>
<b>Closed caption decoders on televisions</b>	<b>No</b>
<b>Flashing light door buzzers available</b>	<b>Yes</b>
<b>Flashing light smoke detectors</b>	<b>Yes</b>
<b>Quiet area in dining room available</b>	<b>No</b>
<b>For passengers with low vision or who are blind</b>	
<b>Daily activity list offered in large print</b>	<b>Yes</b>
<b>Note: On request</b>	
<b>Daily activity list offered in braille</b>	<b>No</b>
<b>Menus offered in large print</b>	<b>Yes</b>
<b>Note: On request</b>	
<b>Menus offered in braille</b>	<b>No</b>
<b>Cruise services directories offered in large print</b>	<b>Yes</b>
<b>Note: On request</b>	
<b>Cruise services directories offered in braille</b>	<b>No</b>
<b>Personnel assigned for assistance in case of emergency</b>	<b>Yes</b>
<b>Cabin steward can orient passenger to cabin facilities</b>	<b>Yes</b>
<b>Elevators have braille, tactile and audible arrival alerts</b>	<b>Yes</b>

<b>Service animals allowed onboard</b>	<b>Yes</b>
<b>Personnel will orient passenger to the ship upon embarkation</b>	<b>Yes</b>
<b>Early embarkation/disembarkation upon request</b>	<b>No</b>
<b>Emergency procedures offered in braille</b>	<b>Yes</b>
<b>Internet café equipped with Jaws and a KOSS - TD/80 headset</b>	<b>No</b>
<b>Tactile and braille signage in public areas</b>	<b>Yes</b>
<b>For Passengers with Diabetes</b>	
<b>24-Hour room service</b>	<b>Yes</b>
<b>Refrigerator in cabin</b>	<b>Yes</b>
<b>Sugar-Free desserts available</b>	<b>Yes</b>
<b>Container for needle disposal on request</b>	<b>Yes</b>
<b>Doctor on board</b>	<b>Yes</b>

**Please note that there is no wheelchair access to the Sports Marina, the outdoor section of deck 4 aft, and all of deck 6 including the Balinese sunbeds. The Top of the Yacht Bar and the golf simulator are also inaccessible by wheelchair.**

**Source document: *SeaDream II Special Needs Info***



UNITED STATES ACCESS BOARD

amusement rides boating facilities fishing piers & platforms golf courses miniature golf sports facilities swimming pools & spa

# accessible boating facilities



a summary of  
accessibility guidelines  
for recreation facilities

JUNE 2003

A FEDERAL AGENCY COMMITTED TO ACCESSIBLE DESIGN

# **Accessibility Guidelines for Recreation Facilities**

## **Introduction**



**The Americans with Disabilities Act (ADA) is a comprehensive civil rights law that prohibits discrimination on the basis of disability. The ADA requires that newly constructed and altered state and local government facilities, places of public accommodation, and commercial facilities be**

**readily accessible to, and usable by, individuals with disabilities. The ADA Accessibility Guidelines (ADAAG) is the standard applied to buildings and facilities. Recreational facilities, including boating facilities, are among the facilities required to comply with the ADA.**

**The Access Board issued accessibility guidelines for newly constructed and altered recreation facilities in 2002. The recreation facility guidelines are a supplement to ADAAG. As a supplement, they must be used in conjunction with ADAAG. References to ADAAG are mentioned throughout this summary. Copies of ADAAG and the recreation facility accessibility guidelines can be obtained through the Board's website at [www.access-board.gov](http://www.access-board.gov) or by calling 1-800-872-2253 or 1-800-993-2822 (TTY). Once these guidelines are adopted by the**



**Department of Justice (DOJ), all newly designed, constructed and altered recreation facilities covered by the ADA will be required to comply.**

**The recreation facility guidelines cover the following facilities and elements:**

- . Amusement rides**
- Exercise equipment**
- Boating facilities**
- . Bowling lanes**
- Fishing piers and platforms**
- . Shooting facilities**
- . Miniature golf Courses**
- Swimming pools, wading pools,**
- Golf courses and Spa**



**This guide is intended to help designers and operators in using the accessibility guide lines for boating facilities. These guidelines establish minimum accessibility requirements for newly designed or newly constructed and altered boating facilities. This guide is not a collection of boating facility designs. Rather, it provides specifications for elements**

**within a boating facility to create a general level of usability for individuals with disabilities. Emphasis is placed on ensuring that individuals with disabilities are generally able to access the boating facility and use a variety of elements. Designers and operators are encouraged to exceed the guidelines where possible to provide increased accessibility and opportunities. Incorporating accessibility into the design of a boating facility should begin early in the planning process with careful consideration to accessible routes.**

**The recreation facility guidelines were developed with significant public participation. In 1993, the Access Board established an advisory committee of 27 members to recommend accessibility guidelines for recreation facilities. The Recreation Access Advisory Committee represented the following groups and associations:**

**▪ American Ski Federation**

**▪ American Society for Testing and Materials (Public Playground Safety Committee)**

**▪ American Society of Landscape Architects**

**▪ Beneficial Designs**

**▪ City and County of San Francisco, California, Department of Public Works**

**▪ Disabled American Veterans**



- **Environmental Access**
- **Golf Course Superintendents Association of America**
- **Hawaii Disability and Communication Access Board**
- **International Association of Amusement Parks and Attractions**
- **Katherine McGuinness and Associates**
- **Lehman, Smith, and Wiseman Associates**
- **Michigan Department of Natural Resources**
- **National Council on Independent Living**
- **National Park Service**
- **National Recreation and Park Association**
- . **States Organization**
- **New Jersey Department**  
**for Boating Access of Community Affairs**
- . **Universal Studios**
- **Outdoor Amusement**
- . **US Army Corps**
- . **Business Association of Engineers**
- . **Paralyzed Veterans**
- **U.S. Forest Service of America**
- **Y.M.C.A. of the U.S.A**

- Professional Golfer's
- Walt Disney Imagineering
- Self Help for Hard of Hearing People

The public was given an opportunity to comment on the recommended accessibility guidelines, and the Access Board made changes to the recommended guidelines based on the public comments. A notice of proposed rulemaking (NPRM) was published in the Federal Register in July 1999, followed by a five-month public comment period. Further input from the public was sought in July 2000 when the Access Board published a draft final rule soliciting comment. A final rule was published in September 2002.

*"Whenever a door is closed to anyone because of a disability, we must work to open it.... Whenever any barrier stands between you and the full rights and dignity of citizenship, we must work to remove it, in the name of simple decency and justice. The promise of the ADA...has enabled people with disabilities to enjoy much greater access to a wide range of affordable travel, recreational opportunities and life-enriching services."*

*President George W. Bush, New Freedom Initiative, February 1, 2001*

## **Boating Facilities**



**The recreation facility guidelines described in this guide focus on newly designed or newly constructed and altered boating facilities. Other provisions contained in ADAAG address elements commonly found at a boating facility, such as accessible vehicle parking spaces, exterior accessible routes, and toilet and bathing facilities. ADAAG addresses only the built environment (structures and grounds). The guidelines do not address operational issues of a facility. Questions regarding operational issues should be directed to the Department of Justice, 1-800-514-0301 or 1-800-514-0383 (TTY).**

**Recreational boating facilities can include fixed and floating facilities. Facilities can vary in size from one boat slip (for example, at a small campground facility) to several thousand slips, and can handle boats ranging in size from small canoes to large sailboats and powerboats. Facilities may be located in the same waterfront area or even in the same site (such as a State park with a large lake) and include marinas, launching facilities, piers, and docks that are designed for recreational use.**

**These guidelines do not cover the design of passenger vessels or ferry docks, and do not address access on and off passenger**

**vessels. These issues will be addressed in future rulemaking for passenger vessels.**

### **Accessible Routes**



**ADAAG requires that at least one accessible route connect accessible buildings, facilities, elements, and spaces on a site . Accessible boat slips, accessible boarding piers at boat launch ramps, and other accessible spaces and elements within a boating facility must also be connected by an accessible route.**

**The accessible route must comply with ADAAG provisions for the location, width (minimum of 36 inches), passing space, head room, surface, slope (maximum of 1:12 or 8.33%), changes in level, doors, egress, and areas of rescue assistance, unless otherwise modified by specific provisions outlined in this guide.**

### **Gangways**

**A gangway is a variable-sloped pedestrian walkway linking a fixed structure or land with a floating structure. Where gangways are provided as part of accessible routes to connect accessible boat slips on floating piers, the following exceptions to the ADAAG accessible route provisions have been included in the guidelines to deal with the varying water level changes and other factors in this dynamic environment. Designers and operators should note that there are no exceptions to the accessible route requirements where the accessible route connects fixed piers to land or other fixed structures.**

### **Gangway Slope and Rise Exceptions**

**Gangways designed for the least possible slope will provide more independent access for persons with disabilities. As a minimum however, gangways must be designed to provide for a maximum 1:12 (8.33%) slope but are not required to be longer than 80 feet in length. For example, if the vertical distance between where the gangway departs the landside connection and the elevation of the pier surface at the lowest water level is 10 feet, the gangway would have to be at least 80 feet long. As water levels rise and fall, gangway slopes also rise and fall. At times, this gangway slope may be less than**

**1:20 (5%) and at other times it may be more than 1:12 (8.33%). In smaller facilities with less than 25 boat**

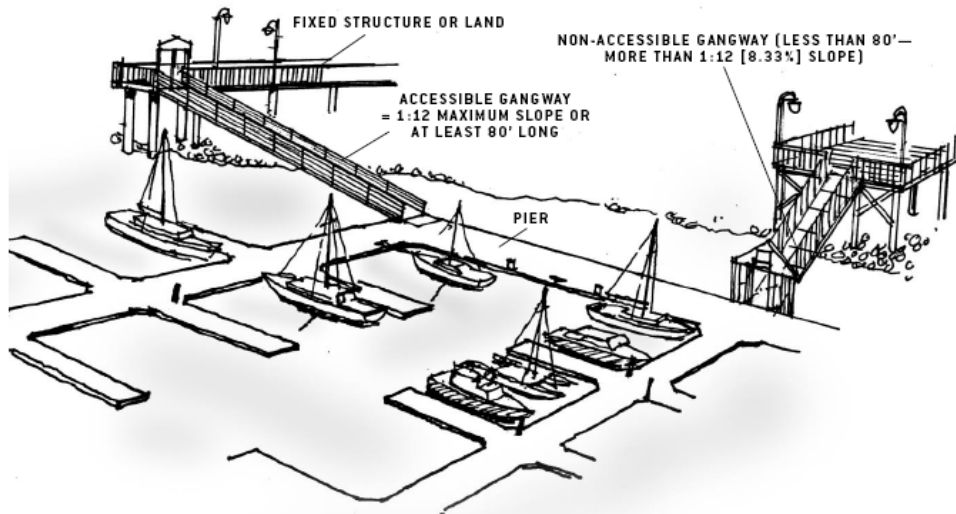

**ACCESSIBLE GANGWAY SERVING ACCESSIBLE BOAT SLIPS IN A LARGE FACILITY**

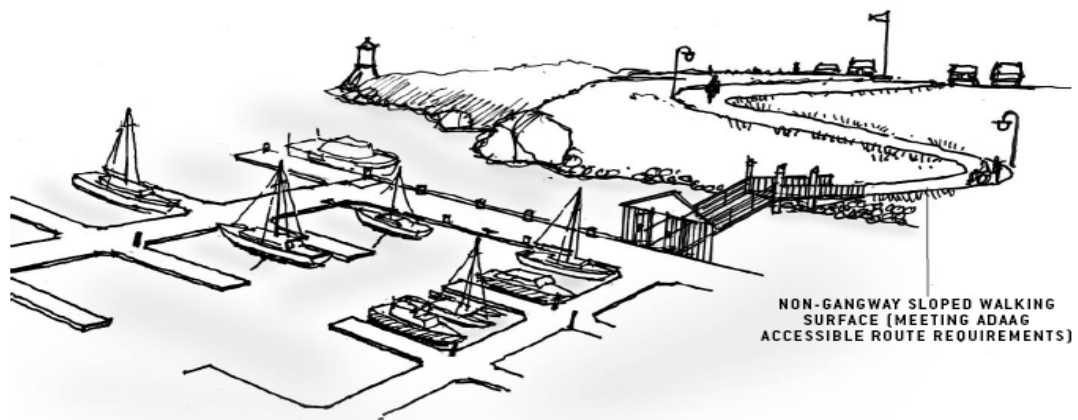

**slips, the slope of the gangway may exceed 1:12 (8.33%), if the gangway is at least 30 feet long.**

**The maximum rise requirements in ADAAG do not apply to gangways. As a result, no intermediate landings on the gangways are required and gangways may be any length.**

**The gangway slope and rise exceptions do not apply to other sloped walking surfaces that may be part of the accessible**



route. For example, where a non-gangway sloped walking surface greater than 1:20 (5%) is provided as part of an accessible route connecting accessible spaces of a boating facility, it must comply with ADAAG slope and rise requirements. This would include a ramp connecting a fixed pier or a float with fixed switchback ramps.

### Gangway Alterations

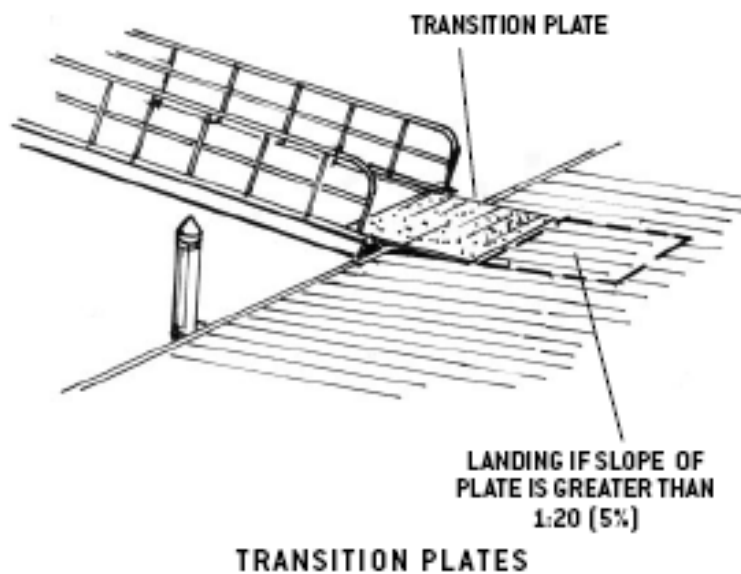

Gangways on existing boating facilities may be repaired or replaced without triggering the requirement to increase the gangway length. However, if the areas altered contain primary

functions (such as a boat slip or boat dock), existing gangways are considered part of the path of travel to the altered primary function area and must be made accessible, if the cost to do so is not disproportionate. The Department of Justice has determined that it is not disproportionate to spend up to an additional 20 percent of the overall costs of alterations to the primary function areas to make the path of travel accessible.

## **Transition Plates**

**Transition plates are sloping pedestrian walking surfaces**

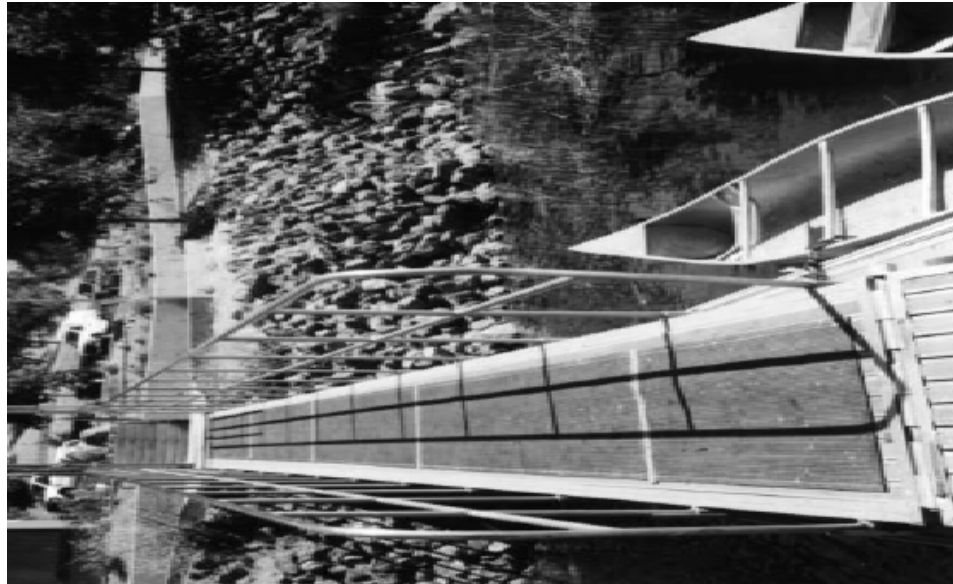

**located at the end of a gangway. Gangways are not required to have landings at the end, if transition plates are provided. If the slope of a transition plate is greater than 1:20 (5%), the transition plate must have a landing at the non-gangway end of the transition plate and comply with other ADAAG ramp requirements.**

## **Handrail Extensions**

**ADAAG addresses handrail height, diameter, and extensions provided to the end of the gangway. Other specifications regarding vertical supports are not addressed by ADAAG, but may be addressed in local building codes. Handrail extensions are not required where gangways and transition plates connect and both are provided with handrails. ADAAG does not require handrails on sloped surfaces that have a rise of less than 6 inches or a projection less than 72 inches, or a slope of 1:20 (5%) or less. Where handrail extensions are provided, they do not need to be parallel with the ground or floor surface, since the surface may be moving due to water conditions.**

## Cross Slope

The cross slopes of gangways, transition plates and floating piers that are part of an accessible route must be designed and constructed to not exceed a maximum of 2 percent (1:50). Gangways and piers that are part of an accessible route are expected to be designed and constructed to meet the 2 percent requirement. Once placed in the water, measurements, absent live loads, are to be made from a static condition (i.e., absence of movement that results from wind, waves, etc.). Where floating piers are grounded out due to low water conditions, slope requirements would not apply.

### Elevators and Platform Lifts

In addition to regular elevators, limited use/limited application elevators (smaller, slower elevators used for low-traffic, low-rise facilities) or platform lifts that comply with ADAAG may be used instead of gangways as part of an accessible route connecting floating piers.

### Boat Slips

A boat slip is the portion of a pier, main pier, finger pier, or float where a boat is berthed or moored, or used for

NUMBER OF ACCESSIBLE BOAT SLIPS REQUIRED	
Total Slips in Facility	Minimum Accessible Slips
1-25	1
26-50	2
51-100	3
101-150	4
151-300	5
301-400	6
401-500	7
501-600	8
601-700	9
701-800	10
801-900	11
901-1000	12
1001 and over	12 plus 1 for each 100 or fraction thereof

embarking or disembarking. Where boat slips are provided, the number of boat slips required to be accessible must comply with the table shown to the right. In these guidelines, boarding piers that are not part of boat launch ramps are also classified as boat slips. For purposes of these guidelines, piers not typically thought of as providing boat slips where boats can be moored, such as a fuel pier, are also included in determining the total number of slips at the facility.

If boat slips at a facility are not identified or demarcated by length, each 40 feet of boat slip edge along the perimeter of a pier will be counted as one boat slip. For example, a new boating facility will provide a single 60-foot pier with boats moored parallel to the pier on both sides. The pier has 120 feet of boat slip edge, which equates to three boat slips. According

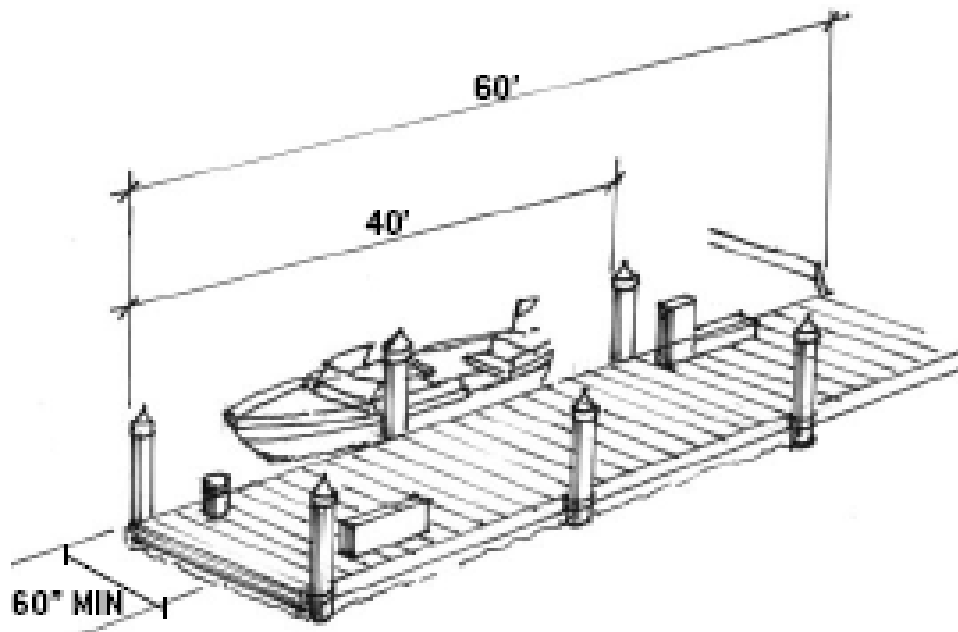

### REQUIRED CLEAR SPACE FOR 60-FOOT PIER

to the table, one slip must be accessible, with clear pier space at least 40 feet long and a minimum width of 60 inches. In this case, the width of the pier is not considered when totalling the amount of boat slip edge, since it is not designed for mooring.

Another new boating facility plans to provide a single pier that is 25 feet long and 3 feet wide and will allow boats to moor on both sides and on one end. The pier has 53 feet of boat slip edge, which equates to two boat slips. According to the table, one slip must be accessible, and the width of the pier must be 60-FOOT PIER increased to a minimum of 60 inches.

### Dispersion

Accessible boat slips must be dispersed throughout the various types of slips a facility provides, but a facility does not have to

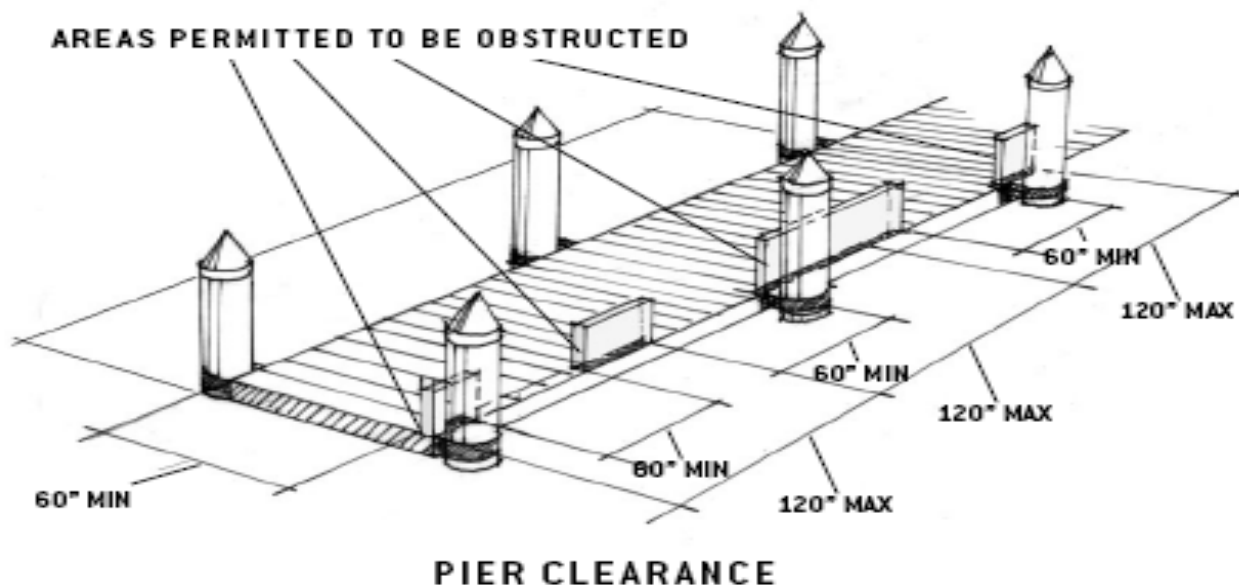

**provide more accessible boat slips than required in the table. Accessible slips may be grouped on one pier if the requirement for different types of slips is met. Types could include shallow-water or deep water; transient or longer-term lease; covered or uncovered; and whether slips are equipped with features such as telephone, water, electricity, or cable connections. Accessible boat slips do not need to be marked and are not reserved in the same way as accessible vehicle parking spaces. For example, facilities should hold the accessible slips open for persons with disabilities until all other slips are filled. At that point, the slip may be made available for general use. For seasonal slip holders, accessible slips should be held until the expiration period for slip contracts has expired. Marina operators may choose to make information regarding accessible boat slips available in promotional material or a facility guide. Ensuring that accessible slips are available to persons with disabilities is an operational issue and operators should contact the Department of Justice for further information.**

### **Accessible Boat Slips**

**Accessible boat slips must have clear pier space at least 60 inches wide and as long as the slip. Providing more than 60 inches wide clear space will improve safety for people with disabilities, especially on floating piers. This space is the minimum necessary for individuals with disabilities to have sufficient space adjacent to their boat slip to use a chair lift or transfer device for getting on or off their vessel and provide a turning space for changing directions. Every 10 feet of linear pier edge serving the accessible slips must**

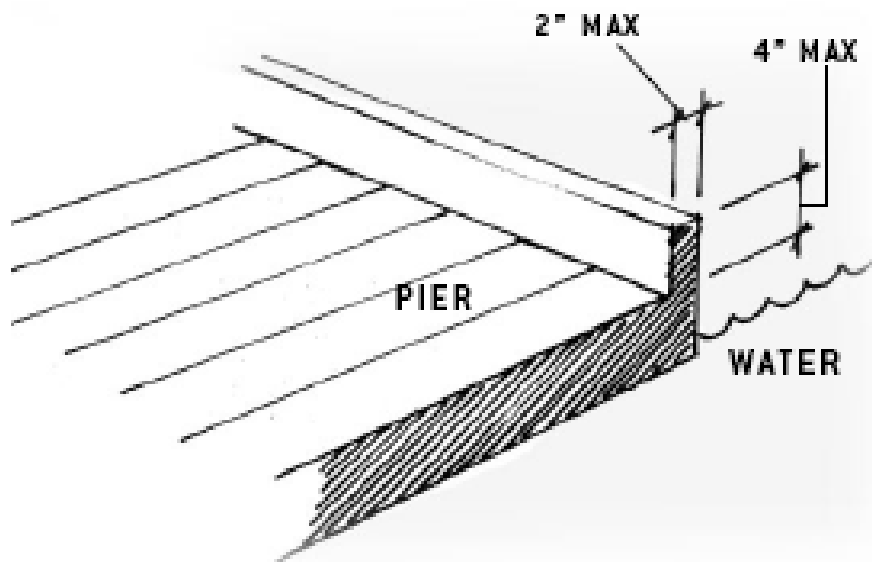
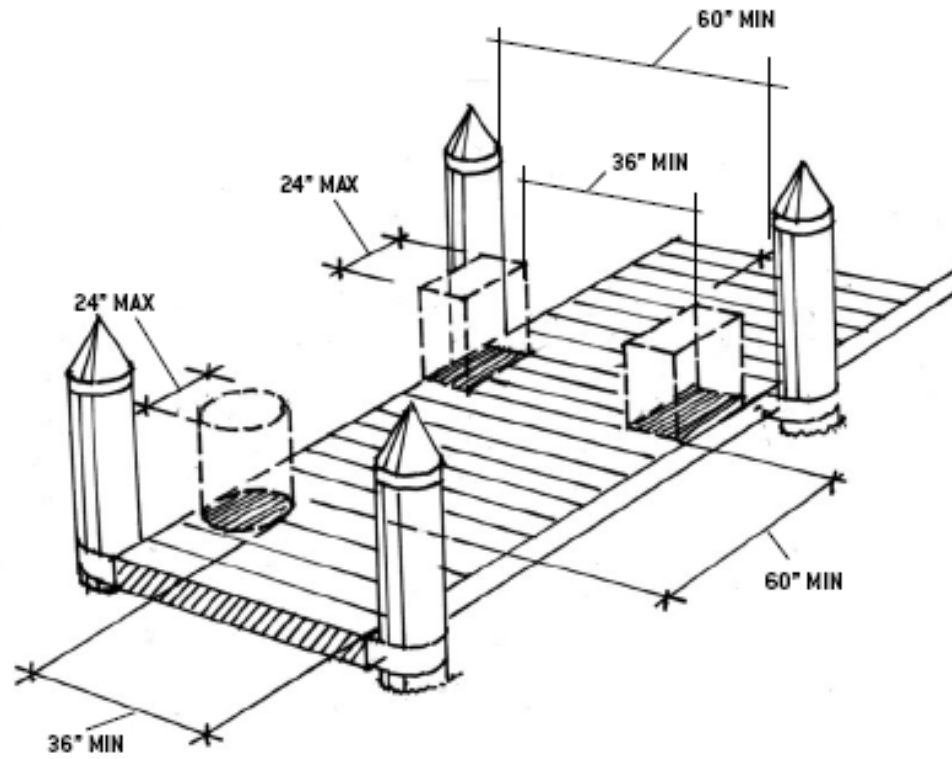

## EDGE PROTECTION AT PIER

have at least one continuous clear opening that is at least 60 inches wide. There are three exceptions: ▪ the width of the clear pier space may be 36 inches wide for a length of 24 inches, as long as multiple 36-inch segments are separated by segments that are 60 inches minimum clear in width and 60 inches minimum clear in length, and the clear openings are at least 60 inches deep.

▪ Edge protection is not required, but if provided, it can be 4 inches high maximum and 2 inches deep maximum at the continuous clear openings.

▪ In alterations, facilities with finger piers must have at least one accessible finger pier, which is the length of the boat slip and a minimum of 60 inches wide. Other accessible slips can be located perpendicular to the end of the pier with

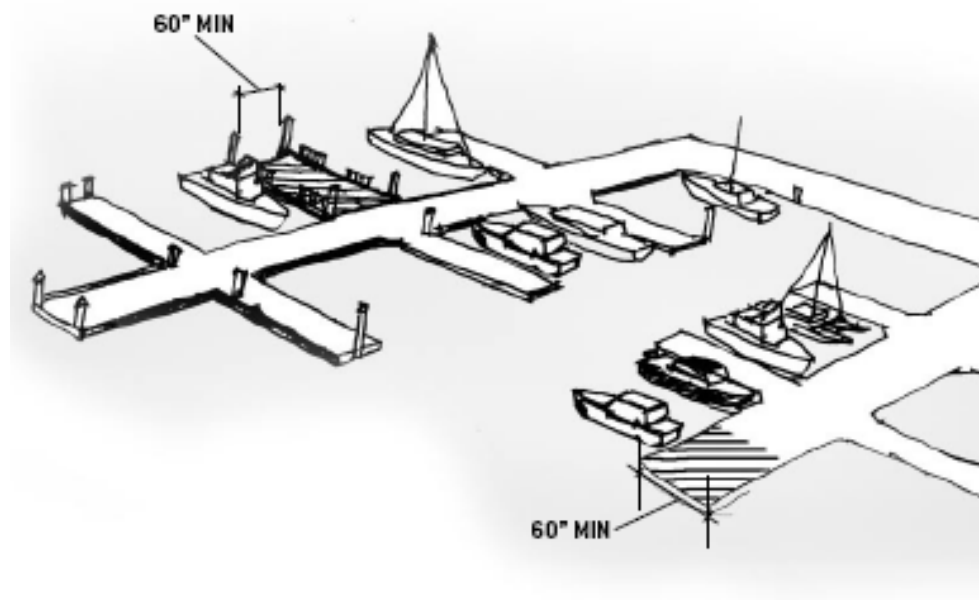

**ACCESSIBLE FINGER PIERS**



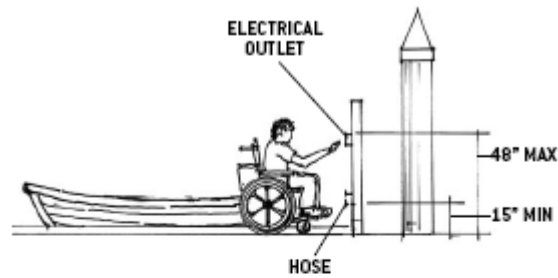

FORWARD REACH RANGES

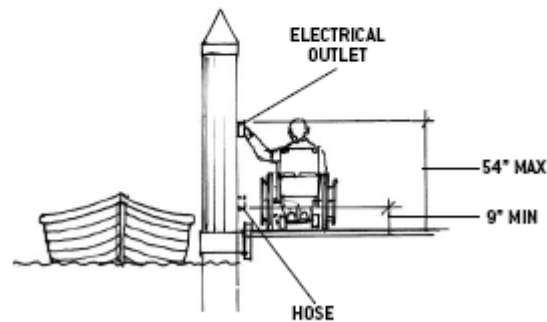

SIDE REACH RANGES

clearance extending the width of the slip. In facilities without finger piers, at least one accessible slip must be parallel to the pier and be a minimum of 60 inches wide (shown above).

Cleats and other boat securement devices at accessible slips do not have to comply with ADAAG reach range requirements. However, clear space must be provided attach securement device and each device must be located on an accessible route. This reach range exception does not apply to other controls and operating mechanisms such as hose bibbs, water supply hoses, outlets for electrical power, telephones, or cable TV

### Boarding Piers at Boat Launch Ramps

A boarding pier (sometimes called a courtesy pier or a launch dock) is the part of a pier where a boat is temporarily moored for embarking and disembarking. A boat launch ramp is a

**sloped surface designed for launching and retrieving trailered**



**boats and other watercraft to and from a body of water. The provisions for boarding piers cover only those that are associated with boat launch ramps. Boarding piers that are not part of a boat launch ramp are classified as “boat slips” for purposes of these guidelines. If boarding piers at boat launch ramps are provided, at least 5**

**percent but not less than one, must comply with these guidelines and be served by an accessible route. The exceptions for gangways, previously described above, may be applied to boarding piers (see pages 5–8).**

**In addition, gangways connecting floating boarding piers may exceed the maximum slope specified in the guidelines, If the total length of the gangway is at least 30 feet. ADAAG ramp requirements do not apply to the portion of the accessible route serving a floating boarding pier or skid pier if it is located within a boat launch ramp. For example, a facility provides a chain of floats on a launch ramp to be used as an accessible boarding pier. At high water, the entire chain is floating and a transition plate connects the first float to the surface of the launch ramp. As the water level decreases, segments of the chain rest on the launch ramp surface, matching the slope of the launch ramp. An accessible route must serve the last float because it would function as the boarding pier at the lowest water level, before it possibly grounded out. Because the entire**

chain also functions as a boarding pier, it must comply with all ADAAG provisions, including the 60-inch minimum clear pier width provision. Another facility provides a non-floating boarding pier that is supported by piles and divides a launch area into two launch ramps. An accessible route must connect the boarding pier with other accessible buildings, facilities, elements and spaces on the site. Although the boarding pier is located within a launch ramp, because the pier is not a floating pier or a skid pier, no exceptions apply. To comply with ADAAG, the accessible route could run down between the two launch ramps. Or, the fixed boarding pier could be relocated to the side of one of the launch ramps, which would allow the slope of the launch ramps to remain unchanged since the accessible route would run outside the launch ramps.

#### **Boarding Pier Clearances**



The entire length of accessible boarding piers must comply with the same technical provisions that apply to boat slips. There is no minimum length for the pier. However, the accessible boarding pier should be at least as long as other piers provided at the facility. If no other boarding pier is provided, it should be at least as long as what would have been provided if no access requirements applied. For example, at a launch ramp, if a

20-foot accessible boarding pier is provided, the entire 20 feet

**must comply with the pier clearance requirements. If a 60-foot accessible boarding pier is provided, the entire 60 feet must comply with the pier clearance requirements.**

### **Launch Ramps without Piers**

**There are no specific provisions that address access to launch ramps without boarding piers. The Department of Justice advises that if there are no applicable scoping requirements (i.e., how many features must be accessible), then a reasonable number, but at least one, must be accessible. It is recommended that an accessible route serve at least one launch ramp. The portion of the accessible route located within the launch ramp is not required to comply with the slope requirements for accessible routes. More Information You can obtain copies of the recreation facility guidelines, which include boating facilities, and further technical assistance from the U.S. Access Board at [www.access-board.gov](http://www.access-board.gov), 1-800-872-2253, or 1-800-993-2822 (TTY).**



***Ms. Shivani Gupta***

***With a double graduation in Hotel Management and Architecture, and a PG degree in Inclusive Environments from UK under her belt, Shivani Gupta is a well known Access Consultant in India. In the last eight years of her work, Shivani has authored several subject books on accessibility which are widely used as resource manuals by the practicing architects and designers. She is regularly nominated by the Government of India as a subject expert to advise on issues and policies relating to accessibility, and has been a recipient of several awards including the Cavinkare Ability Mastery Award (2008), National (Role Model) Award given by the President of India (2004), Neerja Bhanot Award (2002), Red and White Social Bravery Award (1999), and Sulabh International Women of the Year Award (1996) for her consistent inputs towards promotion of inclusive environments. She presently chairs AccessAbility, India's premier Access Consultancy firm, and, with her motto 'Access = Ability', strongly believes that an inclusive environment significantly contributes towards making a better tomorrow for all.***

## **Is Delhi ready to accommodate disabled visitors during the Commonwealth Games?**

*Ms. Shivani Gupta*

*Director, AccessAbility*

**As the clock is ticking for the Commonwealth Games, Delhi is seemingly gearing up fast, The government is spending \$37.5 b into Delhi to make it ready for 2010 Commonwealth Games. There is tremendous spur in infrastructure development to meet the deadlines.**

**There will be an expected inflow of 50,000 foreign visitors during this time requiring 30,000 hotel rooms to accommodate them as per Jones Lang LaSalle Hotels (JLLH), global hotel investment service firm. With less than 2 years left for the event there are presently only about 11000 rooms available with an obviously huge dearth of available accommodation. In this crunch there is neither a talk about accommodation for visitors with disabilities nor any concrete efforts are being made in this direction. If the Government was to take a count of rooms that are accessible for disabled visitors, the numbers will not be more than 80 considering that only 4 star and 5 star hotels need to be accessible.**

### ***Regulation for Accessible accommodation***

**The Ministry of Tourism has a voluntary scheme for classification of fully operational hotels in categories. These classifications are made so as to equip Indian tourism sector to meet international standards. The 4 star, 5 star and 5 star**

**Deluxe hotels have some basic accessibility requirements they need to comply with in order to get the star rating from Ministry. A brief of these requirements is as follows:**

a) Classification Checklist	1*	2*	3*	4*	5*/5* D
<b>General</b>					
Accessible <b>Lifts</b> for buildings higher than G + 2	N	N	N	N	N
<b>Public Areas</b>					
<b>Accessible Public Restrooms</b>					
<b>Ramps</b> with anti-slip floors and handrails at the entrance.					
<b>Minimum door width</b> should be 32" to allow wheelchair access and other facilities for the physically challenged	D	D	D	N	N
Wheelchair access with suitable table in at least one <b>Restaurant</b> .					
Facilities for <b>Aurally/ Visually handicapped</b>					
<b>Safety &amp; Security</b>					
Visual & Audible <b>Fire and Emergency alarms</b> .	N	N	N	N	N
Earmarked Accessible <b>Parking</b> Facilities	D	D	N	N	N

**(N = necessary; D = desirable; \* = star)**

**Through these classifications the Ministry of Tourism require all new hotel projects to adopt facilities for physically challenged persons, since 31<sup>st</sup> December 2003 the ministry mandated all existing 4\*, 5\* and 5\*D hotels to add facilities for physically challenged persons.**

### ***The Ground Situation***

**As per the Ministry of Tourism's 'Hotel Classification System' all 4 star, 5 star and 5 star deluxe hotels should have incorporated accessibility by January 1, 2004. Based on a research conducted by AccessAbility, a leading Universal design consulting firm in Delhi which also makes travel guides for**

**tourists with disabilities, in 2008 shows the reality far from being so.**

**The research was conducted on 15 hotels in Delhi. The breakup included eleven 5 star hotels and four 4 star hotels. The study evaluated these hotels based on requirements of a wheelchair user.**

**While according to the criteria for the stars awarded by the Ministry of Tourism all these should have been accessible to guests with disabilities, the ground reality reveals that only:**

- 33% hotels had a guest room that could be used by a guest on a wheelchair user.**
- 7% had accessible public restrooms**
- 73% had at least one restaurant that was accessible.**
- Out of the four 4 star hotels that were reviewed, a glaring 50% of them had absolutely no provisions for guests with disabilities.**

### ***Major Drawbacks Noticed***

**Considering that all 4 and 5 star hotels should have been accessible by 1<sup>st</sup> January 2004 but almost five years later the reality remains bleak. Some of the major drawbacks that have emerged are as follows:**

- 1. Ambiguous and inadequate accessibility requirements in the present Hotel Classification System - Considering that design layout for disabled must meet some minimum space requirements, the lack of these specifications in the rating criteria opens the doors for subjective**



**interpretation by hoteliers thereby resulting in the 'facilities for physically challenged' guests that are actually unusable by the very client group these facilities are supposed to cater. Also the Hotel Classification System does not include fitness and entertainment areas that are bundled into the room tariff. Additionally these classifications do not adequately address needs of people with sensory impairments.**

- 2. Lack of accessible budget hotels – Presently the accessibility requirement of the Hotel Classification system apply only to the 4 star and 5 star hotels. Accessibility is not a requirement that budget hotels need to fulfil, forcing the majority of disabled travellers to spend their entire savings on luxury hotels.**
- 3. Poor enforcement by the Ministry – The evaluation and auditing committee deputed by the Ministry deputed for checking against the said classification before a hotel gets its star rating have no knowledge of accessibility for people with disabilities and hence are unable to check the disabled friendliness of the various hotels.**
- 4. The exemption mechanism not specified – There may be instances where the existing structural limitations, especially in heritage hotels, make it difficult to cater to the needs of persons with disabilities. There is no exemption mechanism specified by which hoteliers may apply for to get a waiver in such instances.**

## *Summary*

**With the upcoming Commonwealth Games, it is not only will the requirement for regular accommodation that will multiply, but also the need for accessible accommodation will increase many fold. While people are aware and working towards filling the regular accommodation shortfall, there is no awareness or concern about accessible accommodation for visitors with disabilities. Today Delhi may boast of merely 80 hotel rooms that are supposedly accessible (based on their star ratings) to disabled travellers and that too only in the 4 star and 5 star categories.**

**While the Ministry is planning to revise the Hotel Classification requirements but it is not clear yet if they will strengthen the accessibility component of this classification. Even if they do consider strengthening it – the time may not be enough for the industry, especially the budget hotels, to gear up the increased demand of accessible accommodation.**

**For further information, please contact:**

**Shivani Gupta**

**Director**

**AccessAbility | Delhi**

**Mob. (0) 9310245743**

**[shivani@accessability.co.in](mailto:shivani@accessability.co.in)**

**[www.AccessAbility.co.in](http://www.AccessAbility.co.in)**



**Vikas Sharma**

**E-mail: [vikas@accessability.co.in](mailto:vikas@accessability.co.in); Mobile no. - (0044) 07961855855, (0091) 9910383522**

**PROFESSIONAL EXPERIENCE**

**Chief Access Consultant, AccessAbility, New Delhi, India (Nov 2006 – present)**

**Access Consultant, Svayam (CSR programme of Jindal SAW Ltd), New Delhi, India (Nov – Dec 2006)**

**Advisor, REMAP (south-east division), a UK based charity which makes customized engineering solutions for people with disabilities (July 2006 – present).**

**Member, 'Disability Equality Scheme' Implementation Working Group at Royal Berkshire NHS Foundation Trust, UK (July – December 2006).**

**Co-auditing for the editing of a book titled "Access in London" written by Mr. Gordon Couch, published by Quiller Press, London, UK (July and August 2002).**

**Guest Lecturer on "Accessibility" and "Assistive Technology" for M.Sc. Occupational Therapy (Neurology & Orthopedics), College of Occupational Therapy, Jamia Hamdard University, New Delhi, India (February 2002 to September 2002).**

*Master Trainer, "Access for all – A New Initiative" (a series of six workshops) organized by Ministry of Social Justice and Empowerment. Government of India July 2001 to March 2002).*

*Lecturer on "Home Modifications" and "ADL Adaptations" for Rehabilitation Council of India's "Career Training Program" at Indian Spinal Injuries Centre, New Delhi, India (April 2001 to July 2002).*

*Member, National Core Access Committee, Ministry of Social Justice and Empowerment, Government of India (May 2001 to September 2002).*

*Technical Advisor and Board Member of 'ACCESS', a NGO/ Voluntary organization promoting architectural access and independent living for people with disabilities (October 2000 - present).*

*Clinical Occupational Therapist, India & UK (August 1998 - present)*

# **Importance of Anthropometric Research in developing Regional Accessibility Standards**

*Mr. Vikas Sharma*

*Chief Access Consultant, AccessAbility, India*

[www.AccessAbility.co.in](http://www.AccessAbility.co.in)

## **About AccessAbility**

- **Motto: Access = Ability**
- **An organisation working towards inclusion of PwD through:**
  - **Providing infrastructural accessibility**
  - **Promoting job opportunities**
  - **Sensitization and awareness**
  - **Research in Inclusive Environments**
- **The services we provide for Infrastructural Accessibility include:**
  - **Access Audits & Appraisals;**
  - **Access Consultancy - Implementation Strategies,**
  - **Architectural support services;**
    - **Research – developing local technical standards;**
    - **Subject training – architects, designers, town planners;**
    - **Information dissemination – website, online discussion forum, etc.**

## **Background – Barrier Free Environment**

- **The concept of 'Barrier-Free Design' evolved during the Civil Rights and Disability Rights Movements in 1970s to prevent discrimination against people with disabilities**
- **Physical barriers were recognized as a hindrance to freedom**
- **The 1990's finally acknowledged the special needs of the 'differently-abled' and prohibited discrimination on the basis of disability through the enactment of the**
  - **Americans with Disabilities Act (1990) in the USA,**
  - **Persons With Disabilities Act (1995) in India and**
  - **Disability Discrimination Act (1995) in UK .....  
the list goes on**

## **Anthropometrics**

- **the measurement of dimensions of the human body**
  - **physical characteristics (i.e. peoples' sizes) and**
  - **abilities of people (i.e. how people move)**
- **provides information that is essential for the appropriate design of occupational, public, residential and recreational environments, as well as for the design of consumer products, clothes, equipment and tools**

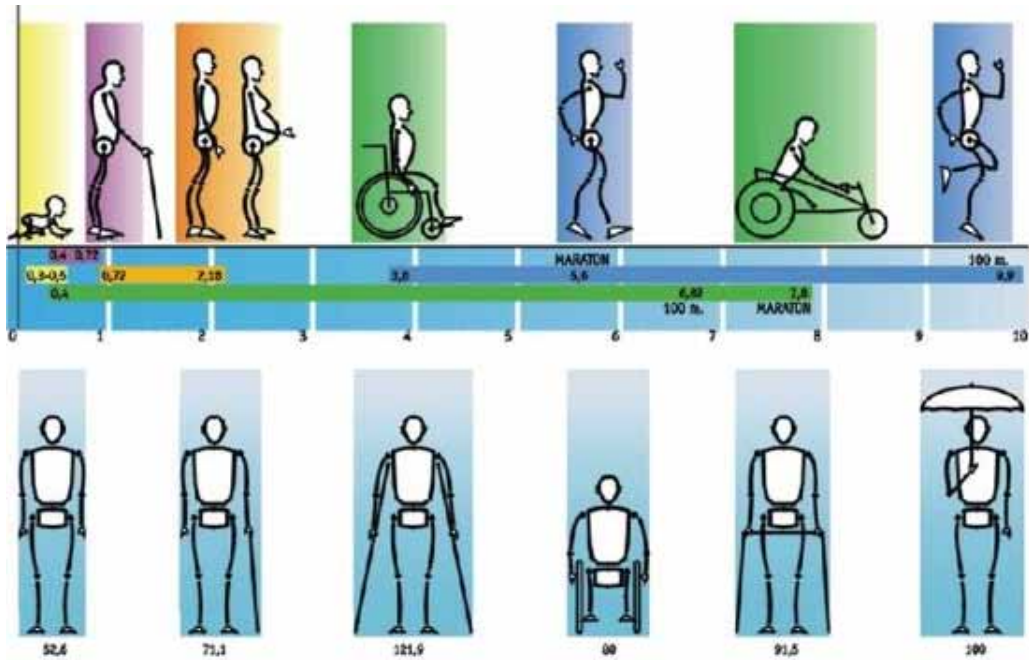

### Anthropometrics & Inclusive Design

- Anthropometric data permit the policy makers and designers to include as large a population as possible.
- Guidelines & Access Standards are based on dimensional data derived from anthropometric research on PWD.

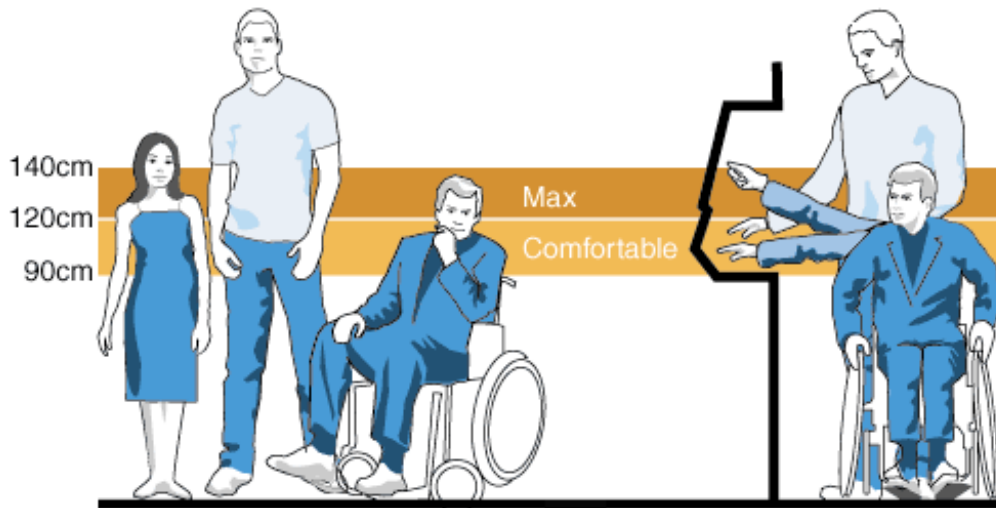

## Application of Anthropometry

- Anthropometric data is statically represented in terms of mean, median, mode, standard deviation and percentiles
- Designers draw upon 5th percentile female stature to 95th percentile male stature.
- Static anthropometric data is very useful but should be carefully applied, because:
  - when people move their static measurements don't reflect the actual size required
  - important to understand how people relate to their environment

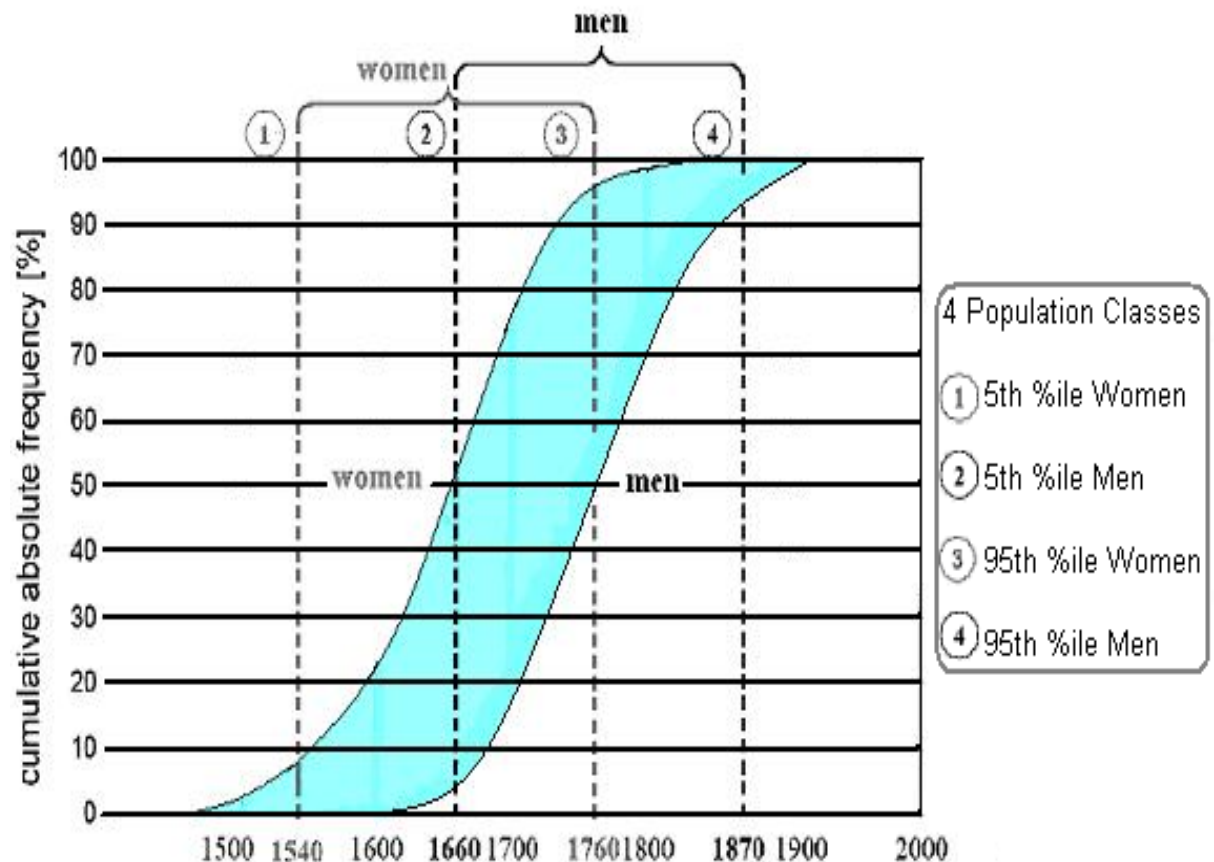



## **Problems with existing databases**

- **Insufficient Database**
  - **Very few studies include the elderly and PWD**
    - **This severely limits our ability to design environments and products that are usable by all**
  - **The most comprehensive anthropometric studies have focused on non-disabled adults, from western worlds, with much of the work performed on military personnel (Paquet, 2004).**
    - **Data collected exclusively from able bodied persons is useless when designing inclusive environments**
    - **Data that is directed towards populations of users and wheelchairs in predominantly western countries and their environment has limited application in this region where people's sizes, characteristics of assistive devices used and the environment are all different.**
- **There are no standards for the measurement techniques to produce this data (Brown et al.,1995; Goswami, 1997)**
- **The anthropometric data typically used by designers is extremely outdated, with many of the data sources and tools developed in the 1970s or earlier (Steinfeld and Paquet, 2004).**
  - **Since this time, there have been important changes in**

- the physical characteristics of the population,
  - the demographics of the population and
  - the technologies used by wheeled mobility users.
  - Most recent anthropometric studies have been conducted in UK, USA, Australia and Canada
- evidence suggests that the current access standards in use no longer represent the range of using population.
  - All these countries have revised or are revising their standards.

### Indian Accessibility Standards & Guidelines

Name	Developed by	Published	Revised	Enforcement
<b>IS4963: Recommendations for Buildings and Facilities for the Physically Handicapped</b>	<b>Bureau of Indian Standards (BIS)</b>	<b>1968</b>	<b>1992</b> <b>(Being aligned with ISO/TR 9527)</b>	<b>Standard</b>
<b>National Building Code</b>	<b>BIS</b>	<b>1970</b>	<b>2005</b>	<b>Standard</b>
<b>IS 7454: Rehabilitation Equipment-</b>	<b>BIS</b>	<b>1974</b>	<b>1997</b>	<b>Standard</b>

<b>Wheelchairs, Folding, Adult Size – Specification</b>				
<b>Guidelines and Space Standards for Barrier Free Built Environment for Disabled and Elderly Persons</b>	<b>Central Public Works Department</b>	<b>1998</b>	<b>1998</b>	<b>Guideline</b>
<b>Planning a Barrier Free Environment</b>	<b>Office of Chief Commissioner, Disabilities</b>	<b>2001</b>	<b>2001</b>	<b>Guideline</b>
<b>Delhi Building Byelaws (proposed)</b>	<b>Delhi Municipal Corporation</b>	<b>2005</b>	<b>-----</b>	<b>Standard</b>

### **Standard Wheelchair (IS 7454)**



## Statement of Problem – Indian Context

- **Indian anthropometric standards were made in early 1970s**
  - **No documented anthropometric research to back these up**
  - **No significant changes in subsequent revisions over the next 3 decades**
  - **No research to verify the effectiveness and validity of the standards**
- **Indian Anthropometric data next to nonexistent (Chakrabarti, 1997)**
  - **Most studies had small sample sizes (under 100)**
  - **Data concentrating on specific applications with few design implications e.g. Kinematics, seating for workplace design.**
  - **Others not from Indian population**



- **None of the standards take into account needs of users of traditional mobility devices**

**Pictures of mobility devices used in suburban and rural India:-**

**Left: Tricycles**

**Below: Castor Carts**

**(Source: UN ESCAP ISBN: 92-1-119775-9)**

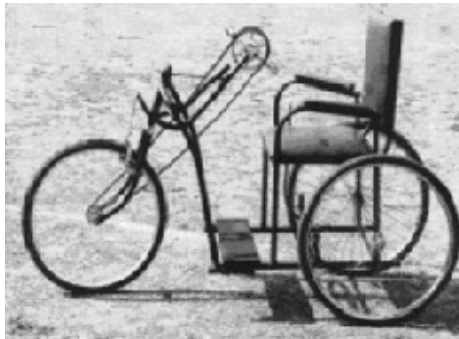

### **Validation Study of Indian Standards**

- **October 2006**
- **Sample size: 15**
- **Site: Indian Spinal Injuries Centre, New Delhi**
  
- **Target population: Manual Wheelchair users**
  
- **Sampling Strategy**
  - **Indians,  $\geq 18$  years of age**
  - **Spinal Cord Injury**

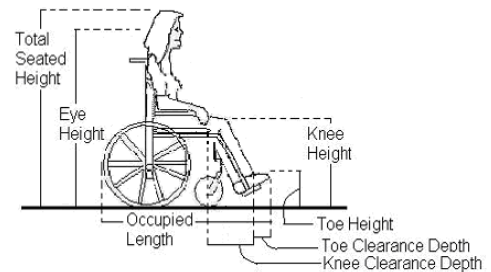
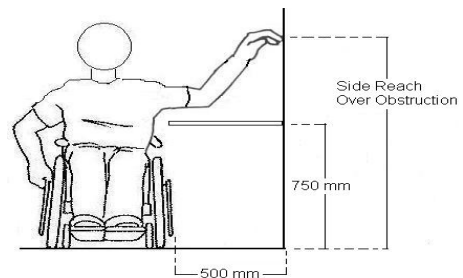

- Using 'own' wheelchair
- Defining variables: see pics
- Measurement protocol: manual, conventional (ruler, tape measure, spirit level, steel square)

### Other Variables Studied

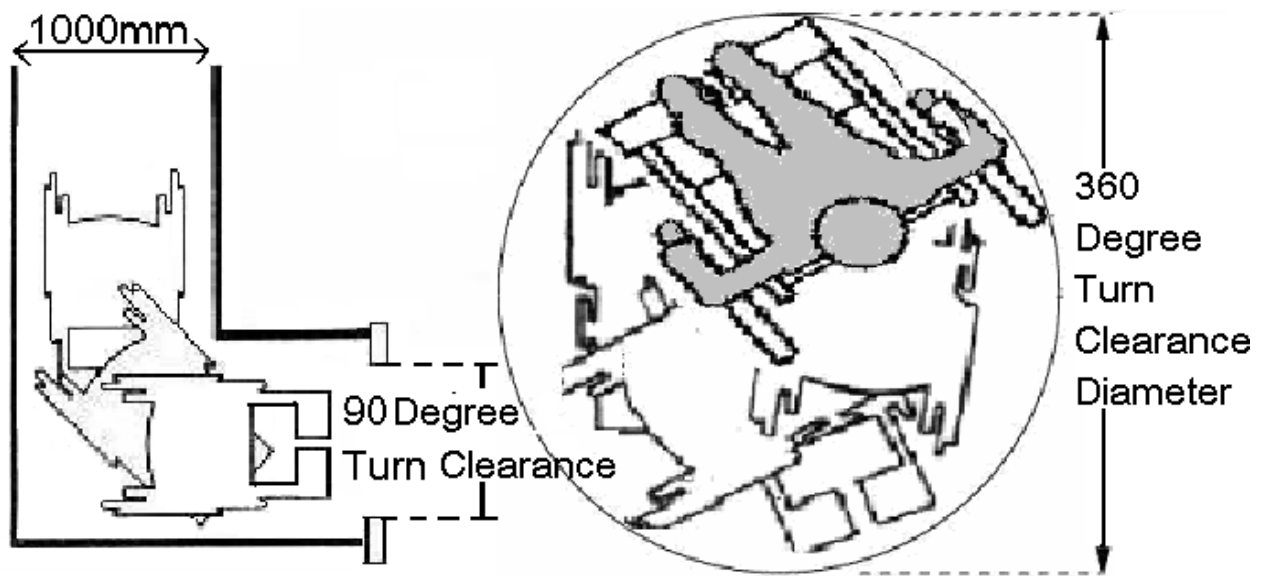

### Recap

- To date, the majority of wheelchair research stems from research groups based in western countries and obviously is directed towards populations of users and wheelchairs in predominantly western countries and their environment.
- The United Nations accessibility guidelines on 'Promotion of Non-Handicapping Environments for Disabled Persons in the Asia and Pacific region' (1995) conclude that:
  - 1) in many developing countries, the necessary professional, land and economic resources have not yet

**been allocated to support research and development work in this field,**

**2) studies of access issues in rural areas are important and remain to be undertaken,**

**3) research methods applicable to local national conditions must be developed, and**

**4) differences in cultural and economic prerequisites must be taken into consideration.**

**..... 13 years later, the research needs still stand unaddressed**

- This stresses the importance of the much needed local anthropometric research in the South Asian subcontinent, if standards are to represent the existing population of regional PWDs.**

## References

- *Brown, R, Rogers, N, Ward, J and Jeffries, G (1995). 'The Application of an Anthropometric Database of Elderly and Disabled People'. Journal of Biomedicine and Scientific Instrumentation, 31: 235-9*
- *Bureau of Indian Standards (1983). National Building Code of India. New Delhi, India. Retrieved 23 February 2006, from <http://www.disabilityindia.org/national.html>*
- *Bureau of Indian Standards (1992). IS 4963: 1987 (Reaffirmed 1992) Indian Standard: Recommendations for Buildings and Facilities for the Physically Handicapped (First Revision). UDC 69'03: 725'54. New Delhi, India*
- *Bureau of Indian Standards (1997). IS 7454: 1991 (Reaffirmed 1997) Indian Standard: Rehabilitation Equipment - Wheelchairs, Folding, Adult Size - Specification (First Revision). UDC 684'432: 615'478'3. New Delhi, India*
- *Chakrabati, D (1997). Indian anthropometric dimensions for ergonomic design practice. National Institute of Design Publication, Ahmedabad, India. ISBN 81-86199-15-0*
- *Goswami, A (1997). 'Anthropometry of People with Disability' (chapter 13). In: Kumar, S (ed.), Perspectives in Rehabilitation Ergonomics, Taylor and Francis Ltd, London, UK. 339-359*
- *International Organisation for Standardisation (1994). ISO/TR 9527: Building Construction - Needs of disabled people in buildings - Design guidelines. Geneva, Switzerland*
- *Paquet, V (2004). 'Preface', Journal of Industrial Ergonomics, 33: 177-180.*
- *Steinfeld, E and Paquet, V (2004). Space Requirements for Wheeled Mobility: An International Workshop. Report Prepared for US Access Board, Washington, USA. Retrieved 13 January 2006, from <http://www.ap.buffalo.edu/idea/Anthro/index.asp>*
- *Stoudt, H (1981). 'The Anthropometry of the Elderly'. Human Factors, 23 (1): 29-37.*
- *United Nations Economic and Social Commission for Asia and the Pacific (1995). Promotion of Non-Handicapping*



*Environments for Disabled Persons: Guidelines. Bangkok, Thailand. Retrieved 02 February 2006, from*

- <http://www.dinf.ne.jp/doc/english/intl/z15/z15009gl/z1500902.htm#E>
- *World Health Organisation (1996). 'Anthropometric Reference Data for International Use: Recommendations From a WHO Expert Committee'. American Journal of Clinical Nutrition, 64: 650-8.*
- *Yammiyavar, P (2005). 'Usability Heuristics and their Role in Designing Vehicles – A Case Study of an Electric-Hybrid Vehicle Body Design'. Journal of the Indian Institute of Science, 85: 67-82. Retrieved 05 February 2006, from*  
<http://journal.library.iisc.ernet.in/vol200502/paper3/67.pdf>

**Vikas Sharma**

**Chief Access Consultant, AccessAbility, India**

[www.AccessAbility.co.in](http://www.AccessAbility.co.in)



*Prof Ms Ketna L Mehta is editor and Associate Dean, Research with Welingkar Institute of Management development and Research, Mumbai, India. She is also Founder Trustee of Nina Foundation, an NGO for rehabilitation for people with spinal cord injury. She is editor of their bi monthly publication: One World, Voice of Paraplegics. She has spinal cord injury due to a paragliding accident in 1995 and champions for the cause of people with disabilities.*

[www.ninafoundation.org](http://www.ninafoundation.org)

[ketna@vsnl.com](mailto:ketna@vsnl.com)

[ketnam@gmail.com](mailto:ketnam@gmail.com)

# **Designing a Disabled Friendly Inclusive World Class City**

## **Imperatives and Issues for Mumbai**

*Prof Ketna L Mehta*

**KEYWORDS:** Disability, PwD (Person with Disability), World Class City.

### **INTRODUCTION:**

**This paper proposes a path breaking concept of a completely disabled friendly city, Mumbai. Generally, when one thinks world class cities, we conjure up images of 4 lane expressways, metro trains, skylines, speed trains, Airports, Malls with a art museum or a Zoo. Designing in this paper is considered in a holistic manner which is a synthesis of logic + knowledge + feeling; its being visionary, futuristic and humane.**

**When people of all socio economic strata are mainstreamed and all have equal access to world class infrastructure that is indeed a world class city.**

**The disabled are at the bottom of the pyramid, so far as the government, BMC or the private enterprises are concerned both in thought and in action. PWD are living, feeling, active human beings contributing to the exchequer as an economic component. The author has conducted an empirical research over the span of 12 years and concludes that a World Class City is one where the differently abled are given dignity and equality by providing quality infrastructure like access, education, employment, health services and recreation. Just**

like the animals in the Zoo and the fishes in the aquarium merit a quality infrastructure, so does the 5 lac disabled in this city. According to census 2001, PWD in Mumbai are 5 lacs (3% of the total population, which according to the sector is a very conservative estimate). The paper benchmarks cities globally like Denver, Berkley, Netherlands and Sydney identifying the facilities and infrastructure and proposes a collaborative effort of the state government, NGOs, educational Institutions and the private sector to implement this basic Human Right that the disabled are entitled to as per the constitution. <sup>1</sup>

### **Constitution and Statutory Provisions:**

The parliament of India enacted THE PERSONS WITH DISABILITIES (Equal Opportunities, protection of Rights and full Participation) ACT, 1995 which cast obligations on appropriate Governments and Local authorities for creating barrier free facilities.

#### **The Law:**

Section 30 stipulates that the governments shall by notification prepare a comprehensive education scheme, which shall make provision for:

- **The removal of architectural barriers from school, colleges or other institutions, imparting vocational and professional training.**

---

<sup>1</sup> *The World benchmark is 2-3% of the total population are disabled. WHO estimates in India it could be 8 -10% but a conservative estimate of 3% of 1,10,00,000 Mumbai population would mean 3-5 lacs are disabled.*

Similarly, section 38 stipulates the appropriate governments and local authorities shall by notification formulate schemes for ensuring employment of persons with disabilities, and such schemes may provide for:

- **Health and Safety measures and creation of non handicapping environment in places where persons with disabilities are employed**

To ensure right to employment for PwD's section 45 calls upon the appropriate governments to provide for-

- a) **Installation of auditory signals at red lights in the public roads for the benefit with visual handicap.**
- b) **Causing kerb cuts and slopes to be made in pavement for the easy access of wheel chair users.**
- c) **Engraving on the surfaces of the zebra crossing for the blind or for person with low vision.**
- d) **Engraving on the edges of railway platforms for the blind or for with low vision; and**
- e) **Devising appropriate symbols of disability.**

In protection of the right to have access to public places, the Disability Act in section 46, enjoins upon the appropriate governments and the local authorities to provide for:

- a) **Ramps in Public Buildings**
- b) **Braille symbols and authority signals in elevators and lifts; and**
- c) **Ramps in Hospitals, primary health centers and other medical care and rehabilitation institutions.**

The architects of the disability act were conscious of the fact that for the creation of barrier free environment in educational institution, vocational training centers, places of work and in other public places, special designs of buildings and special

**technologies would need to be developed. Section 48 of the act calls upon the appropriate governments and local authorities to promote and sponsor research, inter alias, in the on site modifications in offices and factories.**

**As a follow of the PwD act, the ministry of Urban Development, Government of India, in collaboration with UNESCAP, undertook demonstrative exercises in Delhi to create a barrier free built environment in a 2 sq.km area of Indraprastha estate. This further led to a preparation "Guidelines and Space Standards for Barrier Free Environment for Disabled and Elderly Persons" by the central public works department, Ministry of Urban Affairs and Employment. Further a reference was made to all state governments to make suitable amendments in their building bye laws to respond to this act.**

**The bureau of the Indian standard had already brought out the minimum provision to be made in public buildings for providing access to PwDs, way back in 1983 in the National Building code. The planning commission report on the Tenth Five Year plan also stress on issues connected with accessibility for disabled persons.**

**Places of Recreation (Theatres, Auditorium, Parks, etc):**

**Wheelchair Seating**

- Applies to wheelchair spaces in auditoria, assembly halls, theatres and similar facilities.**
- Accessible seating space should be provided in a variety of locations to persons with physical disabilities.**

**Barrier Free Transportation:**

**Every individual including PwDs have an equal right to travel and use public transportation with dignity and independence. It should be regarded as a fundamental right of all citizens, since travel is usually a daily necessity for education, employment, medical attention, entertainment etc. Transport is important in facilitating human communication and face to face meetings. It plays a significant role in economic development of the nation.**

**Constitution and Statutory Provisions:**

**The parliament of India, on many occasions, expressed its concern about persons with disabilities and enacted law to deal with matters connected with disability. The first reference to disability was brought in the seventh schedule of the constitution, which empowered the state government to make laws with respect to relief of the disabled and unemployable.**

**Subsequently, the seventy-third and seventy fourth amendments to the constitution of India made "safeguarding the interest of weaker sections of the society, including handicapped and mentally retarded" a constitutional obligation as referred to in the Twelfth schedule.**

**The parliament of India enacted THE PERSONS WITH DISABILITIES (Equal Opportunities, protection of Rights and full Participation) ACT, 1995 which cast obligations on appropriate Governments and Local authorities for creating barrier free facilities.**

**The Law:**

**Section 30 stipulates that the governments shall by notification prepare a comprehensive education scheme, which shall make provision for:**

- **The removal of architectural barriers from school, colleges or other institutions, imparting vocational and professional training.**

**Similarly, section 38 stipulates the appropriate governments and local authorities shall by notification formulate schemes for ensuring employment of persons with disabilities, and such schemes may provide for:**

- **Health and Safety measures and creation of non handicapping environment in places where persons with disabilities are employed**

**To ensure right to employment for PwD's section 45 calls upon the appropriate governments to provide for-**

- f) **Installation of auditory signals at red lights in the public roads for the benefit with visual handicap.**
- g) **Causing kerb cuts and slopes to be made in pavement for the easy access of wheel chair users.**
- h) **Engraving on the surfaces of the zebra crossing for the blind or for person with low vision.**
- i) **Engraving on the edges of railway platforms for the blind or for with low vision; and**
- j) **Devising appropriate symbols of disability.**

**In protection of the right to have access to public places, the disability act in section 46, enjoins upon the appropriate governments and the local authorities to provide for:**

- d) **Ramps in Public Buildings**
- e) **Braille symbols and authority signals in elevators and lifts; and**
- f) **Ramps in Hospitals, primary health centers and other medical care and rehabilitation institutions.**



**The architects of the disability act were conscious of the fact that for the creation of barrier free environment in educational institution, vocational training centers, places of work and in other public places, special designs of buildings and special technologies would need to be developed. Section 48 of the act calls upon the appropriate governments and local authorities to promote and sponsor research, inter alias, in the on site modifications in offices and factories.**

**As a follow of the PwD act, the ministry of Urban Development, Government of India, in collaboration with UNESCAP, undertook demonstrative exercises in Delhi to create a barrier free built environment in a 2 sq.km area of Indraprastha estate. This further led to a preparation "Guidelines and Space Standards for Barrier Free Environment for Disabled and Elderly Persons" by the central public works department, Ministry of Urban Affairs and Employment. Further a reference was made to all state governments to make suitable amendments in their building bye laws to respond to this act.**

**The bureau of the Indian standard had already brought out the minimum provision to be made in public buildings for providing access to PwDs, way back in 1983 in the National Building code. The planning commission report on the Tenth Five Year plan also stress on issues connected with accessibility for disabled persons.**

**Places of Recreation (Theatres, Auditorium, Parks, etc):**

**Wheelchair Seating**

- **Applies to wheelchair spaces in auditoria, assembly halls, theatres and similar facilities.**

- **Accessible seating space should be provided in a variety of locations to persons with physical disabilities.**

#### **Barrier Free Transportation:**

**Every individual including PwDs have an equal right to travel and use public transportation with dignity and independence. It should be regarded as a fundamental right of all citizens, since travel is usually a daily necessity for education, employment, medical attention, entertainment etc. Transport is important in facilitating human communication and face to face meetings. It plays a significant role in economic development of the nation. People with diverse disabilities (sensory or physical) and reduced mobility (people with health problems for example respiratory, cardio – vascular, joint problems or temporary ailments; senior citizens; pregnant women; families with young children and people with heavy luggage, etc., constitute sizeable number of the population. Since majority of this segment belong to lower and middle income group, it is beyond their economic capacity to use private taxis / three wheeled auto rickshaws or purchase their own vehicle and are, therefore dependent on public transport.**

#### **THE GLOBAL BENCHMARK**

**New Mobility a Publication from USA conducted a comprehensive study of the cities in the USA and arrived at Denver as the most disabled friendly city.**

#### **Denver:**

**It has a population of 468,000 plus with almost 1 million people living in adjacent counties is America's most wheelchair-friendly city. It offers a multitude of services and**

**conveniences, a fully accessible mainline metro transportation system and exceptionally strong advocacy. Years ago, an NGO, ADAPT made accessible buses their business. The result of its efforts is inclusion. The Para transit door-to-door service runs about 23 hours a day, seven days a week, with no limit on number of rides. Personal assistance programs are available, medical facilities are plentiful, and Craig Hospital has terrific support services for people with head or spinal cord injuries. A wide range of recreational and cultural activities: peerless adaptive sports, both integrated and disability-specific arts programs, active ballet and theatre, a symphony orchestra and two opera companies. Coors Stadium--home of the Rockies--is one of the most accessible in the country and, like the Denver Center for the Performing Arts, features universal seating.**

#### **Berkeley:**

**The bay area in general and Berkeley in particular are the cradle of independent living and equal rights for people with disabilities. Berkeley--home to more disability organizations per capita than anywhere else in the world, is number 2 benchmark**

#### **Netherlands:**

**A disabled community in a village close to Amsterdam is a model for disabled-friendly architecture, planning and systems. Accessible transportation system with sidewalks and the works is a dream for any disabled.**

#### **Sydney:**

**Cabs are accessible and a person with disability can independently travel, and even on a wheelchair go trekking or**

rock climbing. Most of the tourist areas are accessible and a person on a wheelchair can visit each and every site. In fact the prison here is also disabled friendly and the facilities offered make the life of inmates convenient with ramps and rest rooms too with zero barriers.

#### **REQUIREMENTS FOR A DISABLED FRIENDLY CITY:**

##### **Access:**

This means that everyone can, without assistance approach, enter pass to and from, and make use of an area and its facilities without undue difficulties. The level mobility of a person who is physically challenged is based on the physical infrastructure of a city. Is there an elevator in the building if not what are the options? Stair Lift, a ramp, a hoist lift or possibility of relocating to a house which is either at a ground level or with an elevator. How many times, one can seek support to be carried up and down. Next is a transportation system. Are the railway stations and trains, wheelchair accessible? All the platforms level is much lower or higher than the train. So what is the point of having one or two Handicapped compartments, when one cannot get inside the same? It is completely apathy and insensitivity for this segment. Now, since last year, BEST has launched star bus which is low floor with a locking facility for people on wheelchair. It does not cover all the routes, it only plays twice a day at fixed time and in a city which works 24 \* 7 does not ply on Sundays. There is no fleet of special cabs with a ramp to freely move about. The Gold cab service started recently has modified only one Versa for a population of 5 Lac disabled in the city. How many schools, colleges and higher education

**institutions have ramps, railings and elevators? Even our centre of excellence IIT at Powai is not world class, as it does not have accessibility. For a bright student qualified to get admission would be discouraged due to this daily drudgery of seeking support to gain physical entry. The students and faculty design world class technology and other products, what does it take to design and implement a barrier free campus? And so also offer to replicate their model to other institutions. Our Indian culture is ancient and very progressive. Apparently the forts which were built had a wide, gradual gradient like a ramp, alongside the innumerable steps – for elephants, who carried all the supplies on their backs (Uttam C Jain’s paper on Access, 2002) How considerate? In the modern age, why don’t our architects, builders and urban planners have holistic thinking and planning while designing our infrastructure? kerb Cuts, Sidewalks, Roads and footpaths all to be convenient for wheelchairs. Thus visibility of a disabled person on the streets is negligible. This designing would also assist the elderly to walk. Singapore, USA, Europe, Australia all has visible signage. Special parking zones for the disabled motorists. They self drive in a modified vehicle park and independently go to their work place or shopping complex. Subways, Streets, recreation centres are all inclusive and its not uncommon to spot a wheel chair player amongst other able-bodied swimming or playing basket ball. Human right is an issue which needs to be addressed on an urgent basis. BEST has started the Star buses recently and it’s a positive move.**

**The bureaucrats and officials need to have a paradigm shift from a charity model to a Humanistic Model. The recent BMC elections had a directive from the election commissioner, New Delhi for accessible polling booths, the compliance was missing. Almost 90% of the disabled had to return without exercising their franchise. This is the state of Mumbai.**

## **Tourism**

**Domestic tourism plays a vital role in achieving the national objectives of promoting social and cultural cohesion and national integration.**

**The National Tourism policy 2002 attempts to position India as a global brand to take advantage of the increasing global travel and trade and vast untapped potential of India as a destination. However, none of the key areas take into consideration requirements of disabled traveller. Also there are no statistics / data available on tourists' with disability (both domestic and foreign) visiting places of tourist interest. There is no database maintained by government agencies of the accessible tourist spots in the city. The efforts made by individuals / organizations are also scattered. There is growing demand, for the tourism industry to improve its services to PwDs: accessible transportation, accessibility within hotel facilities and travel operators to provide tailored packages to PwDs.**

## **Universal Design:**

**Universal design is defined as "the design of products and environment to be usable by all people, to the greatest extent possible, without the need for adaptation or specialized design"**

**In a universal design approach, the user consideration is different as it refer to products and buildings that are accessible and usable by everyone, including PwDs. Rather than providing separate facilities; integral solutions accommodate PwDs as well as the rest of the population.**

**Universal design means products and buildings that are accessible and usable by everyone, including PwDs. Moreover, Universal Design means 'design for all', including people with short stature, tall, obese, frail, elderly as well as young, women as well as men, left handed persons as well as right handed persons. For example, the conventional round handle doorknob is difficult to grasp and turn by persons with hand and upper handle not only benefits those persons whose hands are full, they can open the door with an elbow, forearm or back of the hand.**

**A wheel chair accessible toilet is larger than a 'normal' toilet. But a toilet room, designed with universal design may have larger space clearances in mind particularly for wheelchair users but for with additional facilities: changing tables for babies, grab bars for pregnant woman etc. Besides providing accessible cubicles in a man and woman toilet room, there might be a unisex toilet (family toilet room). This kind of toilet avoids embarrassment when a man escorts his young daughter, a woman takes an older father or a wife takes her husband who is severely disabled. This washroom could meet the needs of people with a wide range of physical limitation.**

## **Employment & Enterprise:**

**3<sup>rd</sup> of December is International Day of the disabled. ADAPT of Spastics Society of India organized a Job Fair, where there were 50 candidates with varying disabilities and only 17 companies offering to recruit. It was a good beginning, no doubt, for a city which boasts of being the financial capital and a vibrant city of entrepreneurs, where talent from all over the country and the world flock. This proves that it is still an uphill task. How many progressive HR departments publicly announce themselves as "An equal opportunity Employer"? NCPEDP (National Centre of Promotion of Employment for Disabled People) each year gives the Helen Keller Award to organisations which are 'Best Employers and which employs maximum differently abled' – till date, only 10 organisations have been awarded from Mumbai, out of the total 62 companies. This is sad reflection of our fast paced city. There is as per the persons with disabilities (Equal Opportunities, protection of rights and full participation) Act, 1995, 3% reservation of the differently abled. How many such posts are filled up and how many are given promotions periodically?**

## **Health – Services:**

**There is marked apathy in the government run hospitals and centres which issue disability certificates. This in-human treatment has to be seen to be believed. There is rampant corruption and in order to avoid expenses in frequent visits at fixed days and time; the non affording PWD also falls in the trap. The system is not at all disabled centric. Information and awareness about various health issues is also woefully missing. There are no insurance policies catering to their needs and no**



guarantee for source of earnings as well as the higher cost of living. Insurance policies for the disabled covering modifications at home is very much needed for periodic purchase of aids and appliances, supplies, medicines, health checkups etc

### **Inclusive Playgrounds:**

**Inclusive Playgrounds are built by a company called National centre for Boundless playgrounds (USA) with sponsorships from the Rotary Clubs and Private Companies. Why should young children be discriminated and not enjoy an outdoor life of a playground. They learn so much in a playground while interacting with children of all abilities, so the design and playground environments reflect the development of children. In Mumbai too we need to increase public awareness of the tremendous need for barrier free playgrounds and how all children, regardless of ability or disability benefit from them. The mantra in USA, where there are such playgrounds is:**

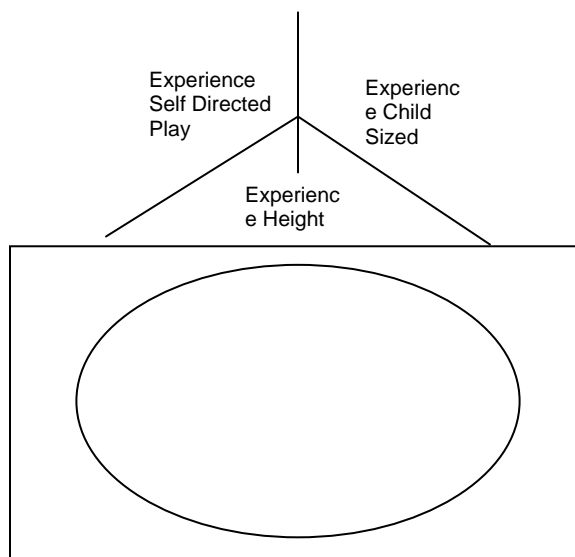

**"Accessible is good. Inclusive is better."**

## **IMPLEMENTATION AGENDA:**

**There are several examples of successful human endeavours which were thought impossible. The Eiffel Tower, an engineering marvel or an arid desert converted into a green belt etc. For any initiative to take off and succeed requires the insight, initiative and a positive mindset. This paper has explained the various issues dogging our city for the disabled, now what is required is the full hearted support and cooperation from all the stakeholders. There is a BMC legislation which mandates all public buildings to be barrier – free. Though it’s a long way off. The strategy would be:**

**Each ward office has a mission plan for the year and by giving three months for the cost allocation and execution for making their ward accessible in physical form. It is achievable. Subsequently all markets, temples, gardens, schools, colleges, clubs etc in that ward have to be audited along with an NGO like ADAPT, ROTARY CLUBS etc. and after assessing the requirements appeal to each place to build the ramp, railing, access facility. Proper signage will create a sense of welcome to the various visitors. BMC has to declare kerb cuts on sidewalks as mandatory and execute phase wise within one year. All new projects whether metro railways, subways, new complexes have to have international standard accessibility features.**

## **CONCLUSION:**

**Mumbai has given to India great minds like Mr. Nani Palkhiwala, acclaimed Lawyer and Advocate of Free Enterprise who has contributed immensely to the financial sector- the**

**core of Mumbai city. Yet in his sunset years, bound to a wheel chair he had to be physically carried up at the landmark heritage Tata Headquarters – Bombay House, a reputed conglomerate with huge CSR budgets. Dignity to a disabled comes at a negligible cost, it's more of a deeper understanding of making our built environment inclusive and granting a disabled the honour of independent mobility. It is more of an attitude and a mindset which can transform our city. A disabled friendly city offering a good quality of life to all its residents is truly a world class city.**

## **BIBLIOGRAPHY:**

*Rehabilitation Council of India; "Access For All – Training Manual to promote 'Barrier Free Environment" August 2005.*

*Mccoey Cindy; "10 Disability Friendly Cities – Where to Live and Why"; New Mobility*

*Dobs Jean; "The Ed Roberts Campus & the power of Nine"; May 2000*

*Nine Foundation – "One World – Voice of Paraplegics" various issues  
www.ninafoundation.org*

[http://www.censusindia.net/disability/disability\\_data\\_main.html](http://www.censusindia.net/disability/disability_data_main.html)

*Prof Ketna L Mehta*

[ketna@vsnl.com](mailto:ketna@vsnl.com)

[ketnam@gmail.com](mailto:ketnam@gmail.com)

# **DESIGNING A INCLUSIVE TOURIST DESTINATION – INDIA**

*Prof Ketna L Mehta\**

*In ancient India places like Gwalior, the forts had 'Haathi Darwaja' exclusively for pachyderms in the forts.*

*Also the forts had slopes alongside steps for elephants who carried food supplies.*

**If the Indian architects of yore cared even for the animals and were so thoughtful to the needs of all the occupants then what has gone wrong in today's India?**

**Is it our indifferent attitude or**

**Is it our education system, which does not include principles of universal design and inclusively.**

**Charles Correa, one of India's well known architects recently stated about the golden olden times:**

*"Architecture was used to give a message to the people"*

---

*\*Editor and Associate Dean, Research, Welingkar Institute of Management Development and Research, Mumbai.*

*Founder Trustee, Nina Foundation (Rehabilitation of people with spinal cord injury)*

**The design of our urban rural scape including the tourist sites in India leaves a lot to be desired. There is scant regard for accessibility for people with disability, senior citizens and the temporarily injured. The message the Indian tourist**

**environment full of barriers gives is 'Sorry you are not welcome; we don't need any additional customers'**

**No other country which boasts of a tourism industry which is flourishing communicates this message as India does.**

**The infrastructure, transport facility, hotels, vehicles, places of tourist interest – none are disabled friendly.**

**The Indian tourism sector is on a all time high with a steady growth of foreign tourists as well as domestic travellers recording high footfalls. Our policy makers and ministry have acknowledged the inclusion of people with disability in the mainstream and laid out all the laws and Acts. Yet India fails. Why?**

**I, myself as a person with disability (spinal cord injury) would like to visit our great heritage sites, temples, beaches, snow peaked Himalayas, our sacred rivers, go river rafting, enjoy the backwaters in Kerala, go sailing and boating and of course enjoy the pristine beauty of one of the greatest wonders of the world – The Taj Mahal in Agra.**

**To do this and enjoy an Indian holiday with family and friends means having an infrastructure that supports and understands the needs of the person with disability.**

**A beginning has been made by way of a mention of fulfilling the needs of PWD in the latest 'Incredible India campaign by the Indian Tourism Ministry.**

**The recently concluded four city seminar series by ASTA with Scott Rains, Craig and Jani Naayar too was a welcome move to highlight the issues and chart out an action plan.**

**India is an emerging tourist destination as well as developing as a super economic power. As such there is great deal of investment in infrastructure projects in the country and by adopting universal design concepts an additional customer base of international and domestic persons with disability would add to the numbers.**

**The medical tourism sector is also being given an impetus and this ties in well with the requirements of the disability sector.**

**It would be a good goal to develop India as an Inclusive Tourist destination and work towards that jointly. This is a Herculean task given the fact that the projects taken up so far are not world class or as per international standards. Also the awareness amongst the service providers has to be uniform for the people with disability enjoying the best of India.**

#### **INDIAN TOURISM SECTOR:**

**Given the unique and immense potential India has as a 'vacation destination', The World Travel and Tourism Council has identified *India as one of the foremost tourism growth centers in the world, in the coming decade.***

***The Ministry of Tourism is looking at increasing the inflow of foreign tourists from 3 million to 25 million in next 10 years. (as per the A C Nielsen ORG MARG report Dec 2007)***

#### **Highlights of the NATIONAL TOURISM POLICY 2002**

**In order to develop tourism in India in a systematic manner, position it as a major engine of economic growth and to harness its direct and multiplier effects for employment and**

poverty eradication in an environmentally sustainable manner, the [National Tourism Policy](#) was formulated in the year 2002. Broadly, the "Policy" attempts to:-

**Position tourism as a major engine of economic growth;  
Harness the direct and multiplier effects of tourism for employment generation, economic development and providing impetus to rural tourism;**

---

- *Focus on domestic tourism as a major driver of tourism growth.*
- *Position India as a global brand to take advantage of the burgeoning global travel trade and the vast untapped potential of India as a destination;*
- *Acknowledges the critical role of private sector with government working as a pro-active facilitator and catalyst;*
- *Create and develop integrated tourism circuits based on India's unique civilization, heritage, and culture in partnership with States, private sector and other agencies; and*
- *Ensure that the tourist to India gets physically invigorated, mentally rejuvenated, culturally enriched, spiritually elevated and "feel India from within".*
- *Keeping in view the basic principles and guidelines of the Tourism Policy, the Ministry of Tourism has been broadly implementing the 10 schemes/programmes during the 10<sup>th</sup> Five Year Plan.*
- *ASIAN DEVELOPMENT BANK has prepared a Technical Assistance Report titled : " India: Preparing the Inclusive Tourism Infrastructure Development Project in Dec 2007. Financed by the Japan Special Fund.*
- *Due to the efforts of the Ministry of Tourism, Government of India have led to India winning the following international acclaims:*



- 1. Conde Nast Traveller, the worlds' leading travel and tourism journal has ranked India amongst the top 4 preferred holiday destinations of the world**
- 2. India amongst the top 5 favourite destinations – Lonely Planet in a survey of 167 countries**
- 3. ABTA (Association of British Travel Agency) has ranked India as No. 1 amongst top 50 places for 2006.**
- 4. The Incredible India campaign has been the winner of PATA Gold Award for best Print Ad Campaign and PATA Gold Award for Best Destination Marketing Campaign The Incredible India Campaign has been ranked as the 'Highest Recall Advertisement worldwide by Travel and Leisure.**
- 5. World Travel Awards received for**
  - 1. Asia's Leading Destination**
  - 2. World's leading Travel Destination Television Commercial**
  - 3. Worlds' Leading Responsible Tourism Project, for Endogenous Tourism Project**
  - 4. Asia's leading tourism and convention bureau**

**It would be a good goal to develop India as an Inclusive Tourist destination and work towards that jointly. This is an Herculean task given the fact that the projects taken up so far are not world class or as per international standards. Also the awareness amongst the service providers has to be uniform for the people with disability enjoying the best of India.**

**Inclusive policy but poor implementation and Execution:**

**A case in point here is the policy of the Government of Maharashtra.**

**GOVERNMENT OF MAHARASHTRA URBAN DEVELOPMENT  
DEPARTMENT**

**DEVELOPMENT CONTROL REGULATIONS FOR GREATER  
BOMBAY, 1991 (PAGE NO. 53)**

**(Published In The Maharashtra Government Gazette, Part I-  
Konkan Divisional Supplement, Dated 21<sup>st</sup> February 1991)**

**41. Special Amenities for Physically Handicapped Persons.  
Special amenities for Physically Handicapped Persons as  
specified below shall be provided in buildings to be used for  
public offices, commercial occupancy or public purpose like  
cinema or drama theatres, hospitals, maternity homes,  
telephone offices, educational purpose.**

- a) A 90 cm. high hand-rail and an additional one at a height  
of 75 cm. above the finished level of steps for staircase  
and for steps to the ground floor plinth even if they are  
enclosed on their sides by walls.**
- b) A ramp with a slope not exceeding 1:12 from the ground  
level of open spaces or road level to the entrance door of  
the lift or staircase.**
- c) One of the wash basins in the toilet block on each floor  
fixed at a height of 80 cm. with a tap at 100 cm. above the  
finished floor level.**

**Thus the policy exists on paper but there is no implementation and action even in the government departments, like MTDC or other tourist offices and centres.**

### **The current need and Status**

**The current status for tourism for people with disability is negligible.**

**There is such scarce disregard for people with disability overall and basic survival for a day to day existence take up most of the waking hours of this section.**

**Travel and tour is supposedly a luxury for a person with disability in India. People travel for relaxation but the poor infrastructure and lack of awareness within the industry makes it a harrowing experience.**

### **ISSUES:**

#### **I] TRANSPORT**

- Transport: railway stations, trains, toilets in trains and platforms are all inaccessible.**
- Airports in major cities have accessibility features, the other towns and smaller cities don't.**
- Road transport like buses and private vehicles are inaccessible.**
- Local transport like accessible taxi services, trains are missing. There are a fleet of low floor buses but awareness about the various timings and bus stops lacking.**

## **II] HOTELS**

- **Except for the five star hotels which have a disabled friendly room there is no concept of the needs of this customer base.**
- **Most hotels and guest houses would have an inaccessible environment**
- **Information about accessible hotels, clubs, guest houses in each town, city lacking, thus it is always word of mouth**
- **The world lack wheelchair for use by guests.**

## **III] PUBLIC RESTAURANTS AND WASHROOMS**

- **inaccessible**

## **IV] PLACES OF TOURIST INTEREST**

- **most places in India in general and Mumbai in particular are inaccessible like the boat ride from The Gateway of India**
- **the zoo**
- **chowpatty and Juhu beach etc.**

## **V] MOBILITY AIDS FOR THE PHYSICALLY CHALLENGED AND ELDERLY AT PLACES OF TOURIST INTEREST are lacking :**

- **beaches**
- **places of religion**
- **heritage sites etc**

## **VI] PARKING FACILITIES – lacking**

## **VII] DISABLED FRIENDLY VEHICLES ON HIRE- lacking**

## **VIII] APPROPRIATE SIGNAGES- lacking**

## **The current opportunity**

**With the inclusion of disabled population in the tourism sector ( local and foreign) there will be increase in the revenue and thus will have a positive impact on our economy.**

**New projects/ infrastructure if designed as universal design concept then we will be on par with the worlds most developed infrastructures catering to broader segment of the society like disabled, senior citizens, temporarily injured, heart patients etc.**

## **Employment opportunities**

**It will increase the employment opportunities for many in disability sector.**

## **ACTION AGENDA:**

**The people with disability have the same rights as per the constitution of the country. All are entitled to the freedom to travel and enjoy the natural beauty and sights of the country. We at Nina Foundation are committed to working towards inclusion in tourism and tourist destination development as a legitimate and ongoing concern in the name of the disabled community of India, its disabled people's organizations (DPOs), and recognizing the support of international organizations in the industry and disability community.**

**It is imperative to bring out changes in the infrastructure and mindsets in the travel and tourism sector in India.**

### **III] AVAILABLE MECHANISMS FOR PERSONS WITH DISABILITIES**

#### **a] Access to built environment and public transport**

- **Model Building Bye Laws prepared and circulated by Ministry of Urban Development, Government of India.**
- **A Grade Railway Stations, Central and State Government buildings, Airports, and some public buildings are made barrier-free.**
- **Visual, audio and tactile signs are being installed progressively.**
- **Some city buses are accessible in Mumbai.**

### **FURTHER ACTION PLAN FOR INCLUSIVE TOURISM**

- 1. Seminar with centre and state government from the tourism ministry and officials from the railway, aviation, transportation sectors about the expectations and gaps.**
- 2. Workshops with the archaeological society, architects, interior designers, hotels about the needs of the disabled travellers.**
- 3. Workshops with all DPOs (Disabled Peoples Organisation) in India – sharing of experiences and achieving the pending agenda.**
- 4. periodic status report about the accessible services and spaces**
- 5. data on number of wheelchair travellers both foreigners and domestic for inbound and outbound.**

## **In Conclusion:**

**All things 'PRECIOUS' are 'TREASURED'**

**Be it our Artifacts which are kept in a museum;**

**Pearls are protected in a oyster.**

**Paintings in an art gallery;**

**Heritage Trees have guards;**

**Precious stones like Kohinoor are kept safely in a case/chest**

**Ancient sculptures in caves**

**Animals like our Bengal tigers etc in sanctuary, nature parks**

**and AND HOW DO WE CARE FOR THE MOST PRECIOUS OF ALL.....**

**THE HUMAN LIFE???**

**In BONDAGE – WITHIN THE FOUR WALLS, DARK ROOM . A PERSON ON A WHEELCHAIR DESPONDENTLY LOOKING OUTSIDE THE WINDOW as if in a CAGE and the outside world is out of bounds.**

**THE BIGGEST GIFT TO MANKIND IS THEIR FREEDOM**

**FREEDOM TO BE FREE.....**

**To travel**

**To enjoy**

**To taste the outdoors**

**Let's 'travel together' for an inclusive society**

*Given the dismal scenario currently, its better to depict the situation in humour and communicate the need for all the stakeholders to awaken to the fact that a person with disability has both the enthusiasm as well as the wallet power to see the sights and beauty of our country. A poem says it all.....*

## **TOURISM FOR THE DISABLED IN INDIA**

*Lets make India travel 'able'*

**In India it's an *adventure* trying to cross the road or travel on the road. (no kerb cuts or slopes) in India, it's a *religious tour* with prayers on our lips, every time we are boarded on the train, bus or an airplane.**

**In India, its *nirvana, spiritual ecstasy* when after a great deal of communication we are able to convince the cop or security guard to allow us to halt or alight from our vehicles.**

**In India, it is an *outing* to the great outdoors, when one makes a regular trip to the hospital after arranging for four persons to carry us in our wheelchairs down the stairs, bundle us into a vehicle or a taxi with a carrier.**

**In India, its *self restraint* practiced by us taught by our seers, when we curtail our fluid and food intake while travelling by rail, road or airplane; as most of the washrooms don't accommodate our wheelchairs.**

**In India it's a *trek* with great deal of hardships when we struggle to get inside a hotel room door.**

**The *thrill* of river rafting just managing to take a bath perched on a WC.**



**In India, *sight seeing* gets a new meaning and dimension, when people stare at us when we are sighted and seen outdoors.**

**In India, the disabled are only next to the *Rishis of the Himalayas* satisfied with a simple joys- abstained from yearning for the yonder.**

*Lets all join together to make India travel 'able'*

*Prof Ms Ketna L Mehta is editor*

[www.ninafoundation.org](http://www.ninafoundation.org)

[ketna@vsnl.com](mailto:ketna@vsnl.com)

[ketnam@gmail.com](mailto:ketnam@gmail.com)



**Mr. Bo Beolens**

*'Bo' [Crombet-]Beolens at nearly 60 has 30 years experience managing public and 'not-for-profit' organisations having been CEO of three different small NGOs and senior manager in several others all serving social needs or disabilities. However, all his 'personal time' has been devoted to green issues and his birdwatching hobby through which he has been three times round the world and visited 40 countries.*

*Owner Operator of half a dozen websites, one the much used birding world resource [www.fatbirder.com](http://www.fatbirder.com) he also writes a regular column in a Birding Magazine as the 'grumpy old birder' and has published one book, has another in edit and a third underway.*

[www.fatbirder.com](http://www.fatbirder.com)

[www.disabledbirdersassociation.co.uk](http://www.disabledbirdersassociation.co.uk)

[www.birderstravel.com](http://www.birderstravel.com)

[www.grumpyoldbirder.com](http://www.grumpyoldbirder.com)

**Founder & Chair – Disabled Birders Association**

**Owner Operator – Anytime Tours and [birderstravel.com](http://birderstravel.com)**

**Creator of Fatbirder & Birding Top 500 Author of 'Whose Bird' & Columnist for Birds Illustrated magazine.**

[www.fatbirder.com](http://www.fatbirder.com) [www.birderstravel.com](http://www.birderstravel.com)

## **Overseas Birding with a Disability**

*Mr. Bo Beolens*

**When I established the disabled birders association (dba) 8 years ago its main intention was to lobby 'the powers that be' to improve access for disabled birders to facilities such as nature reserves and birdwatching equipment. Precious little has happened with the latter despite the multi-million pounds optic industry – do they know they are missing the boat? However, here in the UK at least, service providers, such as the Royal Society for the Protection of Birds [RSPB] and Natural England, have gone from listening with half an ear if we shouted loud, to asking us to help with planning facilities and improving access. There is a long way to go but we are happy that the will is there at the top and on the ground level with only middle management needing reminding every now and then that not all disabled birders use wheelchairs!**

**Having traveled in Northern India with a disabled group [me included], and just planning a trip to the south in February 2009 at the specific request of an Indian outfit anxious to try out a disabled birding holiday and looking for people willing to go with a 'pioneering spirit'; I have a lot of thoughts on accessible travel.**

**On a positive note, my experience overseas has led me to conclude that there are still things the UK could learn both from the car-loving North Americans and the financially strapped third world. In Canada and the US, and to a lesser extent Australia and some African nations many reserves are very**

large and can only be worked from a vehicle [in the case of Africa to stop large carnivores from eating birders whole]. In the UK the idea of cars not mixing with wildlife is still a prejudice to be overcome despite our appetite for wildlife documentaries showing how vehicles are used as mobile hides to film Tigers in India, big cats in Africa and more generally in many other places.

It was never my intention to try to open up the dba as a champion of disability travel but, the very first time we set out our stall at the British Bird Fair disabled birders were asking us about overseas birding trips and we soon set about sorting one out with a service provider who too was looking to break new ground. The trip to Kenya with two wheelchair users and several of us 'hard of walking' types was a great success... but boy was it a steep learning curve too. Kenya was a great choice because of its lack of wealth. This may seem odd, but anyone who has no use of their legs [like our treasurer who, like me, has been on every trip since], finds that third world showers being unsophisticated rooms with a gently sloping floor and a shower head are easy to roll in and out of, whereas, in the 'sophisticated' west, there are marble lips and tiled sills, wrap-round glass doors and fixed cramped cubicles making showing a virtual impossibility.

Moreover, when we did turn up at a couple of lodges with steps into bedrooms or down into dining rooms ramps were made within an hour or two! In fact we turned up at one place to find inaccessible rooms – were taken to lunch and found the ramps had been built and installed in the meantime.

**Transport was not so good as the old VW 12-seater buses we used were not easy to get in and out of and our makeshift wooden ramps lasted less than two days. Luckily we had enough helpers and able-bodied birders to manage to lift chairs complete with user into the vehicle... whilst I am weak in the back I have strong arms and the guide and I managed with a bit of a shove and a tug from our two drivers.**

**You might think that two drivers meant it was a huge group – not a bit of it, there were just six birders and a guide... but, and here is a lesson for anyone wanting to run a tour, two 12-seater busses were ideal! This meant plenty of room for seven travelers luggage [the drivers seemed to exist on the bare minimum] a wheelchair, a mechanized buggy, and us old crocks.**

**Our leader was not the healthiest guy either – he had not long recovered from cancer and the chemotherapy and radiotherapy and had knees prone to giving way as well as a rather too delicate stomach for East African conditions... although, as a South African, he might have taken a chance on non-bottled water.**

**We found that birding in the grounds of Lodges and from or beside vehicles was no different to an able-bodied group so we notched up a pretty good list by the end of our 14 days... in fact the only thing we did not do, that an able group would have, was to go on a very long drive on a very rough road... some of**

**us, me included, do not do well if we are bumped around for more than a couple of hours.**

**Our guide knew his African birds but it was his first trip to Kenya and he was learning fast too, local races of birds made ID a challenge for him as well as us and as a first-timer with a disabled group he was ready to listen and learn as well as guide and plan.**

**Our next trip was not quite the success of the first... Canada in May can be cool – we chose the wettest and coldest May for 50 years to go to Ontario and the migrants were slow in following. Moreover, there were 8 of us, and the guide provided a very plush 14-seater, which was really cramped. On the plus side there was an aluminum ramp which we could use to get the two wheelchair users on board, although it was quite a high step for our caliper user and we had to buy a small plastic stool en route as an added step. Sadly he was a leader not a guide and we had to train him into an understanding that we did not want or need to be led, but were in need of his local knowledge and bird-finding skills. The facilities at reserves were very good with the 1 kilometer boardwalk at Rondeau a highlight with its many places to sit and watch Prothonotary Warblers fighting Black-and-White Warblers for nest places.**

**Accommodation was a compromise too. Using a series of cheap motels solved the problem of ground floor rooms with accessible bathrooms [in North America one HAS to have a certain proportion of disability adapted rooms in any hotel], however, very few places had a breakfast room let alone a proper dining room. Another lesson here as dawn to dusk**

birding is pretty tiring in any event, and with the logistics of loading and unloading people, wheelchairs etc. into vehicles, often the trek for an evening meal was an unnecessary additionally tiring exercise. We found the same problem when we went to Texas and Mexico on a subsequent dba trip. [All these trip reports can be found on [www.anytimetours.co.uk](http://www.anytimetours.co.uk) and additional material on [www.disabledbirdersassociation.co.uk](http://www.disabledbirdersassociation.co.uk) too

Since then the dba or at least some of the dba members have been birding in Northern India, Sri Lanka, Australia, New Zealand, Botswana, Namibia, Zambia, South Africa, Lesotho, Swaziland, Singapore, France, Spain, Hungary, and Poland as well as the aforementioned Texas, Mexico, Canada and Kenya. This year a few of us old hands are off to Southern India with a local outfit who actually invited us to test out local facilities for disabled trips. As always we expect this to be a learning exercise and one where it will not all be plain sailing but we know the tour company is a solid one and, as we have already been to northern India we have every reason to feel confident.

In the north we loved rickshaws at Bharatpur – a perfect way for anyone to see birds, and, of course, spot on for those who find it hard to walk or ‘push’ as wheelchair users say, themselves. The Himalayan foothills by Naintal were beautiful and we managed a terrific list there and in Corbett where birding from the back of open vehicles was the same for able-bodied and disabled alike. When we went down to the Rover at Chambal we had to be helped across pebbles and sand but the boat trip was brilliant and another leveler for all.

**Accommodation was not all perfect of course, but, once more we found that the further up market we went the less accessible it was! The 'international' hotel chain type we used in Agra looked great and had very pretty rooms but split level bedrooms, bathrooms with narrow doors, bars and dining rooms up flights of steps were totally excluding... one of the party could only get to his room via the service lift as there was no lift to the first floor!**

**Over the years we have learned to expect problems. Service providers hate to say no, which is a real problem when it is the right answer to such questions as 'are the bathrooms accessible' or 'do you have sinks that allow you to wheel up close with your legs underneath. I well remember a top class hotel in Singapore that kept taking us to different rooms when we told them we needed one which was accessible... but all rooms were identical! There seems to be one unshakeable conviction amongst hoteliers and restaurateurs... that is that wheelchair users can somehow miraculously get up and walk the last few steps anywhere! Designers please take note... especially the one responsible for the accessible 'disabled' toilet at Delhi airport which is at the top of a flight of 12 steps in a narrow corridor!**

**A glance at the pictures on the websites mentioned with show how we sometimes have to get by... my favorite is one of the dba treasurer, in his wheelchair, being held aloft by a group of Indian tourists who carried him, chair and all, over a newly installed turn-style at a beauty spot.**



**So what are the basics that service providers need to know about?**

**Top of the list are two key phrases much bandied about in the disabled world. One is 'Barrier-free accesses and second is 'the social model of disability'. The first one is easy to explain and uphold... when looking at any public facility, whether it be a private sector restaurant or hotel, or a publicly owned National Park trail or observation platform – do not put unnecessary obstacles in the way. If you need a barrier to keep stock in, or wild animals out, make sure its one that doesn't exclude people... whether they be able-bodied young men, pregnant women, elderly people, children or wheelchair-using birders. In the UK 'kissing gates' and styles are being replaced with large ones that will not only accommodate wheelchairs but pushchairs, prams and even people on horseback! A cattle grid can be designed to keep cattle on one side but allow wheelchairs across.**

**The 'social model of disability' is a tad more difficult but not rocket science... put simply stop making it all the fault of the disabled person... it is not their fault that they cannot use a facility it is the providers fault for not thinking about different needs. The way I look at it is that if all you could buy as foot wear were size 5 stiletto heels most of the world would be up in arms... its obvious that some people want size 10 hobnail boots, so why is it so hard to realize that humanity comes in all shapes and sizes, and in fact it's the majority that are too tall or too fat, too short or too thin, too weak or too dim... most people are not 100% fit and healthy and if something is designed to fit the average person it will actually fit very few!**

**When designing hotel bedrooms or bathrooms make sure things can be reached from a sitting position and there is room to turn a wheelchair around or get alongside the bed or the toilet to transfer yourself and make sure that all showers can be wheeled into. Again its not hard, you don't have to pay consultants or ask the local disabled club to advise... all you have to do stay overnight in your own hotel sitting on a dining chair without ever standing or walking... if you can get in and out of bed, into the shower and use the WC, reach the towels and hang up your clothes then so can your wheelchair using guest.**

**The trickiest thing to get right is transport and there you will need to use your imagination... but a few rules of thumb will help... the lower the access is the better, yet the higher the vehicle is off the ground the better as a lot of viewing will be done from it. Always provide at least two seats per person to allow for luggage, extra 'circulation' space and room for wheelchairs... a 12-seater for four or five people is ideal.**

**Side, sliding doors will probable make access easier and you must give thought to how you are going to get a wheelchair inside or get a wheelchair close enough at the right level to allow for someone to transfer themselves.**

**If I had just one thing to say to the 'powers that be' in India it would be this: "Please remember that only a small percentage of disabled people use wheelchairs. Many more have mobility problems and find distance a big barrier and addressing this calls for some 'thinking out of the box'. Reserves can be**

enhanced by the simplest of benches or perches, even the leaving of fallen trees in situ. Raised viewing ramps make it possible to look at a lot of birds at a distance through a telescope and the planning of 'vistas' if the areas are wooded will help. Sensitive vehicular for disabled people can be managed without any detrimental effect on wildlife, sometimes rules need to be slightly bent to ensure disabled people are not excluded".

And guys please try to be discrete, make provision for everyone but try not to embarrass us less mobile people by drawing unnecessary attention to our needs.

One last thing too... most disabled people have had to cope with their needs for a long time and will know how to far better than you so LISTEN! They will tell you when they need help, by all means offer, but take NO for an answer too. They are the experts in what works for them.

**Bo Beolens**

**Founder & Chair – Disabled Birders Association**

**Owner Operator – Anytime Tours and [www.birderstravel.com](http://www.birderstravel.com)**

**Creator of Fatbirder & Birding Top 500 Author of 'Whose Bird' & Columnist for Birds Illustrated magazine.**

**[www.fatbirder.com](http://www.fatbirder.com)**

**[www.birderstravel.com](http://www.birderstravel.com)**

**[www.anytimetours.co.uk](http://www.anytimetours.co.uk)**

**[www.disabledbirdersassociation.co.uk](http://www.disabledbirdersassociation.co.uk)**

**[www.grumpyoldbirder.com](http://www.grumpyoldbirder.com)**



***Amitoj Singh, Indian Institute of Technology- Delhi,  
IDC, India***

***Earlier worked as Deputy Manager Hero Honda, persuing Ph.D***



***J. Bharat, Indian Institute of Technology-Delhi  
IDC,India***



***Prof & Head Lalit Das  
Indian Institute of Technology-Delhi  
IDC, India  
[laitdas@gmail.com](mailto:laitdas@gmail.com)***

## **Bodystorming at Taj – Designers Day Out**

*Amitoj Singh*

*Lalit Das*

*J. Bharat*

*M. Des. Industrial Design Programme*

*Indian Institute of Technology, Delhi*



**The expression of "Wah!"(Wow) has been synonymous with Taj Mahal for most Indians. We all love this great tribute to beauty and love.**

**With Dr. Rains Scott we learnt, the significance of the journey as compared to the distance. We learnt to observe the journey.**

**The semester had just begun, we had admitted five students against a special grant from the Department of Science and Technology. Dr. Rains Scott was here in Delhi and offered to interact with our students and introduce them to body storming. The brain here takes an entirely new dimension, it becomes sensitive and observant about the needs of the body. A wheel chair was packed and the team set out to Agra to experience life on a wheel chair. This would enable the budding designers to look at the behavioural, cultural and social implications of accessibility in general and products in particular. Though body storming is often used for instant analysis of a new concept or design, it can be quite useful in studying the present situations or environments as well. The major advantage of body storming is to inspire and excite a participant to look for improvements in current situation. Developing an inspiration and self-motivation is one of the most important and difficult aspects in accessible design education. The broader objective was to give a headstart to their new academic life and to test the impact of body storming in motivating and inspiring students to work in the area of accessible design.**

# Accessibility Audit - Taj Mahal

A body-storming exercise was conducted to study the difficulties faced by a person on wheelchair on tourist places. Taj Mahal, Agra was the tourist destination selected for the study.

## Members:

Society for Accessible Travel and Hospitality, US

Mr. Scott Rains

Mrs. Jani Nayar

Accessible Barcelona, UK

Mr. Craig Grimes

## IIT Delhi

Mr. Amitoj Singh (Professor),

Tinton Abraham

Bharat, J

Debidutt Gharai

M. Vishal Raj

P K Suresh Rao Sonkar



The distance between the adjustable Ramps is difficult to manage.

### OPPORTUNITIES:

Folding or Wider Ramps maintaining the slope standards of 1:12 (height:length)



Accessing the switches when there is very little space between bed and wall.

### OPPORTUNITIES:

Designing the layout of furniture and the switch positions



The wash basin is too heavy. Difficulty in accessing the lever. Outlet of the basin not insulated.

### OPPORTUNITIES:

Change from ceramic to light weight materials  
Changing the outlet position so that it doesn't come in contact with body.



The lever used for adjusting the height and position of the support is unable to reach from wheelchair.

### OPPORTUNITIES:

Design of support with lever handle in front.



The bathroom is congested. The door is open outward.

### OPPORTUNITIES:

Doors able to open to both sides. A spacious and fully accessible bathroom



Difficulty in accessing the switch. Height of the table is not suitable for writing.

### OPPORTUNITIES:

Better table designs can be incorporated and Better Positioning of switches and controls.



Ambiguity in identifying the swiping side of the card because of symmetry.

### wall.

### OPPORTUNITIES:

Designing an identification mark on the card which could be felt with hand without seeing.



Difficulty in transferring from wheel chair to the vehicle.

### OPPORTUNITIES:

Specially designed vehicles having provision for accommodating the person along with wheel chair



Bumpy ramps increases the effort needed.

### OPPORTUNITIES:

Finding an optimum balance between the roughness and ease of moving a wheelchair on the ramps.



No railings for the ramps for support.

### OPPORTUNITIES:

Proper positioning of rails on the ramps.



No safety on the edges. The space is not enough for more than one wheelchair to pass.

### OPPORTUNITY

Ramps can be extended along with rails on the edges



Too steep and slippery steps

### OPPORTUNITIES:

Special arrangement like lift could be provided for the disabled instead of stairs.



Comfort carrier Design lacks 100% utility.

Amateur cannot operate without users manual.

Not fully user friendly.

### OPPORTUNITIES:

Design of the comfort carrier can be modified for ease of use.



Difficulty in knowing the correct way to lift a wheelchair if needed to be carried.

### OPPORTUNITIES:

Indicating lifting points on the wheelchair.



Wheelchair is too sterile in looks

### OPPORTUNITIES:

Looks could be improved so as to make the disabled feel more comfortable  
Increasing the storage space



Bharat J.  
2008 JDS 6023  
M.Des, IIT Delhi  
Computer Science Engr, MACE

On their return they continued to work in exploring their environment at IIT Delhi.



# Accessibility Audit - IIT Campus

A body-storming exercise was conducted to study the difficulties faced by a person on wheelchair while moving from one place to another. The source point was the Design Studio and the destination was the IIDC Washroom. The following are the major issues that were found by body-storming.



The position of Exit button and door is be opened to the same side.  
**OPPORTUNITIES:**  
 Door opening and closing design.  
 Position of the biometric device.



Difference in levels of different floors causes jerk while moving.  
**OPPORTUNITIES:**  
 Avoiding difference in floor level.  
 Giving gradual slope



The ramp for wheelchair is too steep. So moving down or climbing up can be difficult.  
**OPPORTUNITIES:**  
 Ramps should maintain the standard dimension of 1:12 or above



Slippery surface while transferring from different levels  
**OPPORTUNITIES:**  
 Resucing level difference gradually and providing rough surface for better grip.



Roads having pitholes and stones and gravels.  
**OPPORTUNITIES:**  
 Providing Footpaths



The bollards will not allow a person on wheelchair to pass. So footpath is completely not accessible.  
**OPPORTUNITIES:**  
 Bollard design to allow pedestrians and wheelchair but not motorbikes



Vehicles parkes in front of the footpath entrance.  
**OPPORTUNITIES:**  
 Strict rules should be enforced.  
 Desiging the footpath to not allow the vehicles to park anywhere near them.



The ramp for wheelchair is too steep. So moving down or climbing up can be difficult. Assistance is required  
**OPPORTUNITIES:**  
 Ramps should maintain the standard dimension of 1:12 or above



Slippery Roads and less space for a person on wheelchair to move if a vehicle passes by  
**OPPORTUNITIES:**  
 Availability of accessible footpaths



Bathroom doors are difficult to reach.  
**OPPORTUNITIES:**  
 Better handle designs.



Conjusted entrance.  
**OPPORTUNITIES:**  
 Increasing the width of the door.  
 Double door facility opening to both sides.



Reaching for the wash basin requires the person to lean forward.  
**OPPORTUNITIES:**  
 Designing the washbasin to accommodate the wheelchair person to slide beneath it and which allows the person to adjust the height.



Spilling water while washing face due to uncomfortable position of body.  
**OPPORTUNITIES:**  
 Adjusting the basin height.



Hands getting dirty and injuries due to rubbing with tyres/wheels  
**OPPORTUNITIES:**  
 Seperate hand protection gloves or an extra feature in the wheelchair for the protection.

Ekant L.  
 2008 IDS 6023  
 M.Des. IIT Delhi  
 Computer Science Enst. MACE

**The following feelings expressed by students, after the visit substantiate the extent of learning (remember its their first**



day at a design college) from there body storming sessions with Dr. Rains Scott and Ms.Jani Nayar,

*"The way I was introduced to the field of design was very different from what a regular student would expect, although it was one of the most fascinating experiences which I have ever had. The trip to the Taj Mahal was to understand a familiar place from a different perspective. Although we did not know much about design, we had an introduction naturally. We carried along with us a wheelchair for gaining that 'true experience'."*

*"Also the psychology of the people was very different and not so concerned because usually it is assumed that tourist places are not for the disabled. After repeated requests and also obtaining permission from top authorities, finally we were allowed inside. Inside the entrance was a very beautiful sight of the Taj looking at us."*

*".....This shows that there is no proper information among the people about the way in which the disabled think and all they expect is independence not pity."*

*"The journey to Taj had made me more sensitive towards disabled and also inspired and motivated me, because of which I would like to contribute to them through my design. Also this experience was very informative because we got a chance to see and experience from a disabled man's perspective and I am sure this was a very rare opportunity which usually come once in a lifetime, and I would cherish this experience all my lifetime."*

**Madhira Vishal Raj**

*“Everything was going fine until my turn came which was near the security checking centre near the main gate of the TAJ. I was also entering the main gate for security check sitting on the wheel chair as if I was also disabled. But to my shock the security guard told me to take my stuffs from my pants pockets for the security check and I just stretched my legs like a normal human and he was suspicious .He told me to stand up and I had to the same. Then he told me to walk. I was so embarrassed in front of the crowd, I was standing there and the people were looking at me as if I was a terrorist came in disguise as a handicapped to bomb Taj.”*

*“From this we could make out some basic idea of the great majority towards wheel chair people. They look at them with a suspicious attitude if they get up from that chair, or are considered like why the hell they want come to this tourist place when they are supposed to take rest either in hospitals or in their home.”*

*“What we could understand was that, there were no measures taken by the government to built ramps near to any of the steps ,so that the at least the wheel chair laden people can go to the Taj. There we came to the conclusion that all the disabled people are considered as a burden in all tourist places and it requires a Herculean task to change the kind of mentality of the mass majority towards them.”*

*Tinton Abraham*

*“None of the officials were ready to take responsibility of people who were disabled and fearing the media, they refused to allow us inside Taj Mahal. We were asked to submit,*

*otherwise, a written statement stating that someone from our team took all responsibility on any unfortunate happenings."*

*"Design should not target only a part of population but it should be Universal."*

*Bharat J*

*"We enjoyed the beauty of Taj Mahal and wonderful sights of Taj on wheel chair only. There were uneven tiles which is very difficult for disable to move on those tiles on wheel chairs. They should be smooth."*

*"The journey to the top of Taj was really tiring. Then the interior was the exciting part to watch. The beauty speaks itself. Then we decided to design something more accessible. The chair should be physically more active and alert and easily portable....."*

*Debidutt Gharai*

*"By providing such kind of facilities, one will get appreciation for adding value to the society, which needs such solutions. From marketing or business point of view Accessible travel may involve some sort of investment. But this can make us all feel that, we are also a part of the society, and we also have rights to enjoy life as other do."*

*Pawan Sonkar*

**"Welcome to the Real World".....We thought to ourselves listening to our enthused, inspired and motivated students.**

## Book Received:

1.

# WALKING ISN'T EVERYTHING

AN ACCOUNT OF THE LIFE OF JEAN DENECKE

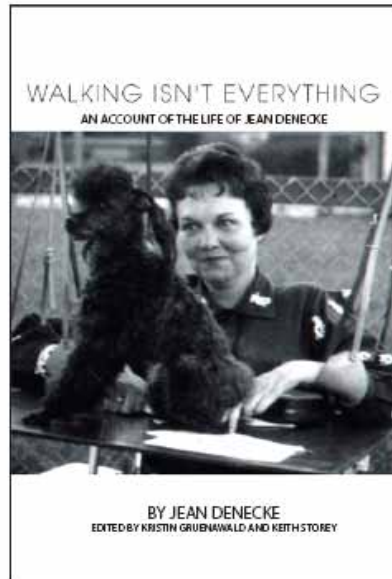

*“As inspiring as it is touching.”*

*Walking Isn't Everything* was written by Jean Denecke about her experience of living with polio. This book discusses what it was like to get polio, her experiences with various hospitals and doctors, and her experience in the Roosevelt Foundation facility in Warm Springs, Georgia. Giving a glimpse of how the delivery of medical services have changed since the polio epidemics of the early 1950s, the book describes what it was like to be a woman with a disability in that era.

Even though she was hospitalized for a long time, after going to Warm Springs, she was able to return to her home where she continued in her role as a wife and mother, and later started her own business.

*Walking Isn't Everything* is more than just a biography of one remarkable woman—it is a story of courage, determination, and love.

Includes introductions by Mary Lou Breslin from the Disability Rights Education Defense Fund and Martin Harmon from the Roosevelt Warm Springs Institute for Rehabilitation.

### About the Author

Jean Lucille Denecke was born October 23, 1917 in Akron, Ohio. After graduating high school, she moved to Detroit and worked as a hostess at Stouffer's restaurant and eventually married. In 1946, she contracted Polio and, after nine months in the hospital, she was able to return home in an iron lung. A year later, she spent four months at the Roosevelt Foundation in Warm Springs, Georgia where she was fitted with braces and a proper wheelchair. Although she never regained the ability to walk, she was able to take care of some of her personal needs, write, dial a phone and breathe without assistance. In 1954, she founded a small business which she ran from her home by telephone. Jean Denecke was active in her church, and charitable organizations. With assistance and support from her husband, she raised her family and was an inspiration to others. She died of a cerebral hemorrhage March 10, 1969 in Dearborn, Michigan.

## Special Offer (Save \$2)

*Walking Isn't Everything* is available in both paperback and electronic formats suitable for assisted-reading devices and software.

Paperback: \$16.95  
eBook formats: \$12.95

Order before March 31, 2009 and save \$2 off of the regular paperback price.

CCO  
CRYSTAL DREAMS  
publishing

Place your order now, directly with the publisher, and when checking out, use the coupon/discount code "POLIO" to receive a \$2 discount.

Place your order at:

[www.CrystalDreamsPublishing.com](http://www.CrystalDreamsPublishing.com)

## 2

### Universal Design in Home Design

J. W. Elphinstone does a very good job of arraying the research-based arguments for Universal Design in home remodeling. Quoting Wendy Jordan, author of a book

"A lot of people think that making a house more accommodating will

make the house less stylish, but there are many (universally designed) homes that are beautiful and still work well for people young or old, tall or short, or if they have any kind of limitations."

**Universal Design for the Home: Great Looking, Great Living Design for All Ages, Abilities, and Circumstances (Paperback)**

by [Wendy A. Jordan](#) (Author)

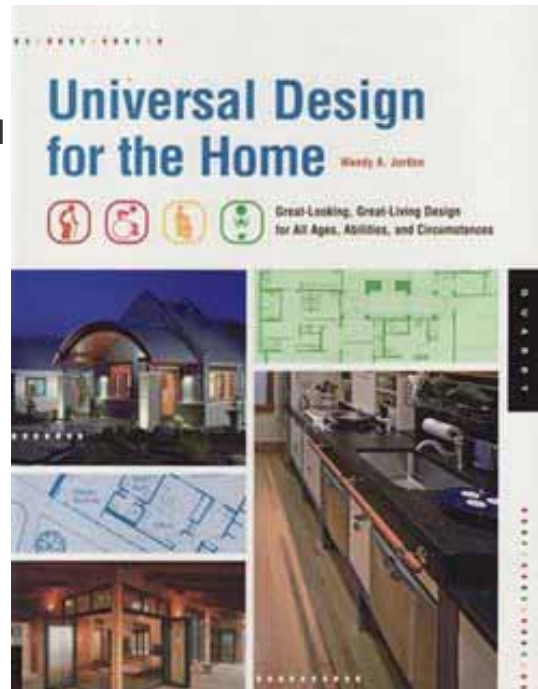

## News:

1.  
"Taiwan Design Expo 2008" that was held from the 4th to 19th of October in Taiwan.

I produced the exhibition stand "JAPAN UNIVERSAL DESIGN EXPERIENCE PAVILION" there with the collaboration of 30 Japanese companies which have worked on the Universal Design for years.

On the opening day, the stand was full of visitors who have great interest in the design come from Japan and the Universal Design itself, and also Mr. Ma, a President of Taiwan, visited our pavilion and tried riding an "i-unit" of TOYOTA Motor Corporation and looked around all products showed there.

In addition to the exhibition, I had a workshop for children, field trip "UD Explore", and lecture there. I just attached some images took from each activities, and I would be happy if you could see those.







2.

User Experience Design Update **Newsletter** - October, 2008.

Why the Bradley Effect is not about race

View online -

<http://www.humanfactors.com/downloads/oct08.asp>

(Web version includes references)

In this issue:

Chief Scientist Kath Straub, PhD, CUA, looks at social motivations and polling.

**WHY THE BRADLEY EFFECT IS NOT ABOUT RACE**

3.

November 12, 2008

[\*\*Tech Museum honors tech that benefits humanity\*\*](#)

Posted by [Elinor Mills](#)



**A Huichol woman does bead work while her son finishes his homework by the light of a Portable Light device.  
(Credit: KVA MATx)**

**Living in San Francisco, we take technology for granted. We have YouTube and iPhones and online maps. We get annoyed when a Web page downloads too slow or our phone call drops. Then there are the millions of people who don't live in developed countries, who go without the Web and even electricity and light for most if not all of their day. For them, things like Windows 7 and Facebook are irrelevant, but they still dominate the technology landscape.**

**There are some innovators designing technology for use by the rest of the world, companies and nonprofits that are applying technology to help people improve their lives. The Tech Museum in San Jose, Calif., offers its [Tech Museum of Innovation awards](#) to projects that apply technology to benefit humanity.**

**Established in 2001, the awards recognize 25 laureates in the categories of education, equality, environment, economic development, and health. One laureate in each category will receive a \$50,000 cash prize. The winners will be announced at a ceremony on Wednesday night at which professor Muhammad Yunus, a pioneer of microcredit and founder of Grameen Bank, will speak.**

**CNET News talked to 5 of the 25 laureates and got a glimpse of some of the technologies that are doing things like preventing spread of disease from reuse of infected needles, monitoring the air around farms for dangerous pesticides, turning the PC into a 3D design tool, and bringing light to dark places on the map.**

**Textiles that illuminate**

**Sheila Kennedy was traveling in Mexico studying solar applications in 2002 when she saw a group of native Huichol women cooking by the side of the road because they had insufficient light to cook in their homes and she had an epiphany. She saw a practical use for flexible solar panel technology and solid-state lighting that her architectural design firm in Boston, [Kennedy & Violich Architecture](#), was experimenting with.**





**A Huichol woman wears a Portable Light device integrated into textiles that can be worn.**

**(Credit: KVA MATx)**

**She formed a nonprofit, the [Portable Light Project](#), and began a collaboration with renewable-energy think tank The Rocky Mountain Institute to launch a pilot project with the Huichol in the Sierra Madre mountains in north central Mexico. The project provides a way for indigenous communities to have bright light inside their homes at night, recharge the power with the sun during the day, and charge cell phones and medical devices as well. Participants in the project receive solar kits that they integrate into their textiles to suit their needs. The**

**kit includes one or two thin-film 10-by-4-inch photovoltaic panels, an LED, and a control pouch with digital drive electronics and a small lithium-ion rechargeable battery. The self-contained renewable energy source is lightweight, easy to integrate into existing materials, and is customizable.**

**"It's an elegant textile surface that can be folded or formed," Kennedy said. "It's got great optics, with parabolic reflector shapes made from folded textiles which bounce reflected light from solid-state lighting sources."**

**It takes about 2.5 hours to fully charge a battery and it offers about 10 hours of light at about 100 lumens using only 1 watt. By contrast, a 100-watt, 120-volt bulb produces 17.5 lumens per watt.**

**Projects are under way for Nicaragua, and the Brazilian and Venezuelan Amazonias. The group also is working to use ultraviolet-emitting LEDs for a water purification capacity using portable light. And in another project, Portable Light has created a hospital blanket using the nanotechnology for medical workers in South Africa to send home with patients with HIV who are bedridden.**

**"Sunlight kills bacteria that causes tuberculosis, but many of the patients sit at home in the dark," Kennedy said. With the blanket "they can wrap themselves in the blanket, produce**

electricity, store it, and then provide power for their family and caretakers around the clock."

### **Syringes that save lives**

Brit Marc Koska was living in the American Virgin Islands in the early 1980s, "with a first-class honors in beach bum," when he saw a newspaper article about how the reuse of syringes in developing countries would make them a major transmission route for HIV infections. He decided to work on tackling the problem and eventually developed the K1 Syringe, the world's first syringe that automatically disables after it is used once.

**Marc Koska talks to some Indian boys at risk of getting infected from needle sticks while digging through a dump. (Credit: Star Syringe )**



**A ring in the barrel of the syringe locks the plunger in place once it is fully depressed so it can't be used again. The syringes sell for about 5 cents, he said.**

**Twenty-four years later, and 17 years of no sales, Koska, now 47, heads up [Star Syringe](#) with 14 licensees around the world producing more than 2 million K1 syringes a day. It is estimated that his syringe has saved more than 5 million lives. "The manufacturing process was the lowest hanging fruit," he said. "It was critical to make a design that would easily retrofit onto existing machinery."**

**Currently, half of the injections given in the developing world are unsafe (the rate rises to 65 percent in India) and the World Health Organization reports that reused syringes are believed to be responsible for 1.3 million deaths a year, mostly malaria.**

**"A mother taking her baby to a doctor for any routine vaccination could leave with hepatitis or HIV" because the**

doctor reused an unclean needle, Koska said. "It happens for many reasons, including poor distribution of supplies, but informing the public of the issue will be critical in tackling this global problem."

His next project, [SafePoint Trust](#), does just that.

**Monitoring the air for carcinogens**

For decades, people living near farms in California's Central Valley complained that they got headaches, fainted, or got sick after pesticides were sprayed on nearby crops.



**Jorge Alvarado operates the Drift Catcher while PANNA Scientist Karl Tupper stands by.  
(Credit: Sara Bjorkqvist)**

**Pesticide exposure has been linked to increased incidences of certain types of cancer, birth defects, Parkinson's disease, asthma, and other illness. According to a 2007 study, autism rates for children born to California women exposed to certain pesticides during their first trimester of pregnancy were six times greater than normal. Still, communities have been told that spraying is safe. Without any proof otherwise it seemed there was nothing that could be done.**

That is until Dr. Susan Kegley developed the [Drift Catcher](#) for the San Francisco-based [Pesticide Action Network North America](#) (PANNA).

The device is an easy-to-use, affordable air monitoring system that measures the concentrations of hazardous pesticides in the air. A vacuum pump pulls air through two glass sampling tubes. The tubes contain a resin which traps pesticides as the air moves through. Tubes are typically changed every 24 hours and samples must remain cold until they are analyzed by PANNA scientists in the laboratory.

"The device enables communities to scientifically document when levels of pesticides in the air near their homes and playgrounds exceed what the Environmental Protection Agency says are safe," said Kathryn Gilje, executive director of PANNA.

"Now, we can amass enough data to make a change in policy to make (pesticide drift) illegal," Kegley said. "Air sampling has been around for a long time, but now you can do it cheaply enough so someone can set it up in their back yard" and start measuring when they see the tractors spraying pesticides.

The Pesticide Action Network has about 50 of the devices out in the field. The Drift Catcher has been used by community activists in California, Minnesota, Florida, Washington, Indiana, Maine, and Hawaii.

Evidence from the Drift Catcher devices likely played a role in keeping the maker of the herbicide molinate on track for voluntarily withdrawing the chemical from the market. It also played a role in the EPA requiring larger buffer zones around fumigated fields and requiring farmers to provide notice to the community about what pesticide they are using, Kegley said.

The group also is pushing the U.S. Department of Agriculture to help farmers move away from using toxic chemicals and adopt safer alternatives.

#### **Renewable light by the hour**

Andy Schroeter learned first-hand about the difficulties people in developing countries have getting affordable access to light sources when he was working in Laos and Vietnam for a German development organization beginning in 1995. Not only are 44 percent of the population in Laos off the electricity grid, but paying for kerosene to light lamps winds up being one of the highest costs for a household.





**Men in Laos get trained on how to operate solar panels that recharge lanterns rented to villagers. Note the solar panels on top of their hats.**

**So Schroeter created the [Sunlabob Renewable Energy](#) company to help solve that problem.**

**Based in Laos, the company rents large central solar charging stations to village businesses which, in turn, rent out rechargeable exchangeable solar lanterns to households. The lanterns can be used to charge mobile phones, small TVs, radios, and laptops.**

**"We are creating a sustainable model for a village," Schroeter said. "In rural areas in developing countries people don't have the cash to pay for initial investments for the hardware."**

**Each lantern has an integrated microprocessor that alerts a user when the power is low and collects data that can be used for carbon offset purposes.**

**The lantern light lasts for about 10 hours and costs as little as 40 cents, Schroeter said, adding that light lasts as long as three days for families in Laos.**

**In addition to Laos, Sunlabob is providing services to villages or has franchises in Uganda, Cambodia, Singapore, and Tanzania and will soon be operating in Afghanistan.**

**3D for the masses**

**When Daniel Ratai was 13 he wanted to design cars. But he found that using pencil and paper was too limiting and there were no computer programs that would allow him to do exactly what he wanted.**



**Research institutes are using Leonar3Do for pharmaceutical research.**

**(Credit: 3D for All)**

**"In kindergarten I tried to draw 3D designs on paper. I dreamed about drawing into the space," says Ratai, a Hungarian. "I could imagine the car in my head and see it on the top of a table."**

**So, when he was 18 he started working on a system that would let him do as he wanted. His firm, [3D For All](#), developed the Leonar3Do console and specialized software that works with any PC.**

**Sensors attach to the monitor and the user wears a pair of 3D goggles and draws with a 3D pen, creating whatever their mind can imagine in the space in front of the monitor.**

**The system can be used for creating virtual environments, buildings, anything. A research group is using it to control 3D microscopes for molecule docking, Ratai said.**

**Prototypes are currently being tested and initial systems should be available to the public for between \$1,000 and \$1,200 next year, he said.**

**4.**

**MIT [Institute of Design](#) learner wins VDA award.**

**[Ramandeep Singh](#) Ratta final year student of [Post Graduate](#) programme in Transportation design in MAEER's MIT Institute of design Pune has been selected as a prize winner for his work on "FELIDAE [System Design](#)" by the VDA Design Awards 2008 (Verband for Automobilindustrie: German Association of the Automotive Industry).He has been awarded for his work**

at Hannover Germany during the IAA **Commercial vehicle Fair**. He has been given internship at **Mercedes Benz (Daimler)**. Along with Ramandeep, the work of Arun Thomas final year Transportation design student of MIT ID namely "Stream" has been selected as one of seven best entries and have been exhibited/published by the same jury.

The VDA Design Award, now announced for the fourth time, is intended for newcomers to the **international design** profession, to encourage them in a visionary approach to the subject of freight transport by road.

<http://www.vda-design-award.de/index.php?id=1197&L=3>  
<<http://www.vda-design-award.de/index.php?id=1197&L=3>>

5.  
CEPT University at Ahmedabad (India) has recently established a Faculty of Arts and Humanities to explore arts, design, communication and the **social sciences** from an interdisciplinary perspective. The Faculty's first initiative is a Masters Programme in Arts and Communication which will commence in January 2009.

The Masters Programme in Arts and Communication is a two-year, practice based course in arts, design and communication which includes **social science perspectives**. Studio explorations will form the central focus of the programme and will be conducted by senior practitioners from the fields of art, design, film making, performing arts and related disciplines. Integrated with studio practice would be theoretical inputs from experts in the **social sciences** and humanities along with **field studies** and **internship opportunities**. Students completing the course could look forward to careers in the fine arts, design, film making, advertising and also in emerging areas such as art and museum curation and **social communication**. Students wishing to pursue an academic or research career would be mentored accordingly.

This course is open to graduates from all disciplines. For further details visit [www.cept.ac.in](http://www.cept.ac.in) or email [fah@cept.ac.in](mailto:fah@cept.ac.in)

## **Appeal:**

**1.**

**Dear Readers,**

**Please note that some important update on "India Design Report" given below:**

**According to my little experience and observations, Design in India did not get much attention relatively. While other creative division like handicrafts making global foray still design sector is trying to find its feet. Design is just an incidental activity and informal economy, Design not identified as a strategic tool in Indian scenario.**

**One of the main hindered factors is "Lack of communication with government or business associations from designers and design community.**

**As an individual you would like to change scenario?  
You would like to fill the gaps between designers and government?**

**Confederation of Indian Industry (CII) has been actively involved in promotion of Design in the country. One of the recent initiatives taken up by CII on Design is the compilation of India Design Report.**

**The objectives of the design report is:-**

**To describe the Indian design business**

**To know the core competence of the design houses and design schools To promote the mutual interest of the design community**

**To assess mutually beneficial creative business collaboration opportunities To elaborate design infrastructure and design ecology**

**To identify design zones or cluster mapping To showcase of India design potential and make design alliances To develop and share knowledge of design**

**The first comprehensive report on India design sector will create a clear picture of design industry strengths and potentials. The design report will analyze the design sector magnitude and characteristics. And it also gives innumerable**



insights to design promotion in the country.

I believe that India Design Report is a domain centric and collective voice of Indian designers.

Your voice is important and as an individual you can change the scenario, you can fill the strategic gaps and contribute to promotion of design business in India by sending filled up questionnaire to [seema.gupta@ciionline.org](mailto:seema.gupta@ciionline.org) / [rajakumar.kanajam@gmail.com](mailto:rajakumar.kanajam@gmail.com)

You can download the questionnaire from the "Designindia" files section or E-mail to [rajakumar.kanajam@gmail.com](mailto:rajakumar.kanajam@gmail.com)

Thank you so much for your support.

Product Design, Uni. Coventry-06 (MSRSAS)  
[Design Management](#) from Uni. Salford - 08

2.

Hi, can anyone send me links for images of the above. The inspiration is Islamic tradition of the calligraphic wall and interior treatments of surfaces, where they are covered with geometric ornament or calligraphy. I am seeking updated interpretations of this tradition.

Any links or even suggestions of what to look for would be very helpful.

Thanks,

James Hicks "James Hicks" [jamesthomashicks@gmail.com](mailto:jamesthomashicks@gmail.com)

3.

The Bangalore User Experience community seeks your support and invites your participation for [World Usability Day](#) 2008 on Nov 29, Saturday.

The Bangalore event hopes to cover a variety of perspectives on Design in Transportation including keynotes by the COO of [BIAL](#) ([Bangalore International Airport](#)), the head of design at the Maini Group (makers of Reva, India's first [electric car](#)), renowned international [urban planner](#) Mr. Balachandran, and others. In addition to the keynotes, there will also be a series of unconference style presentations, with a focus on the use of technology and media in improving human transportation.

The event is being put together by volunteers of UPA Bangalore, CHI Bangalore, and IxDA with sponsorships and initial support from Yahoo! R&D and HFI Bangalore. We are hoping to get additional community support for volunteering and theme sponsorships. Please email me or any of the other organizers listed on the event page with your ideas and suggestions.

One area where we seek participation is the Poster Exhibition on Transportation stories and solutions. The best poster ideas will both be showcased at the event and in prominent public spaces in Bangalore (in the spirit of the Bay Area Design showcase in San Francisco).

Details for the Bangalore event are available at:

[http://upabangalore.org/?page\\_id=11](http://upabangalore.org/?page_id=11). You can register for both participation and for unconference talks at the event wiki: [http://www.upabangalore.org/mwiki/index.php?title=WUD\\_Bangalore\\_2008](http://www.upabangalore.org/mwiki/index.php?title=WUD_Bangalore_2008).

The event is free and open to all.

On behalf of the organizers  
-Amit Pande

4.

The world's population is aging at a staggering rate. The 50+ population is the fastest growing segment worldwide and predicted life-expectancies are at a historical high.

- An American turns 50 once every seven seconds.
- Within the next few years, 50% of the European Union's population will be 65+.
- By 2030, in Italy, retirees will outnumber active workers.
- By 2050, the median age in Thailand will rise to 50.

With advances in medicine, public policy and technology, people are not only living longer, but many are living better. Today's older adults are more educated and engage in more activities than previous generations, including work, leisure, learning, etc. The modern face of aging is one that expresses vitality and commands a greater quality of life. We must look at the demands of this population with open minds to new opportunities for innovation.

**Innovations from government, business, and research created for the older population will ultimately benefit all ages. An aging society is the opportunity to invent the future of healthy, active living.**

**The 50+ population is the fastest growing segment worldwide  
An aging society is the opportunity to invent the future of healthy, active living.  
We Invite people with ideas / unique concept for better ageing society.**

**Founder President - Silver Innings Foundation, A dedicated Organisation for Elders and their Family Members  
Founder – ARDSI, Greater Mumbai Support Group  
Advisor - Society for Serving Seniors  
Managing Committee Member - ARDSI, Mumbai Chapter  
Mobile: 0091 9819819145  
Website : [www.silverinnings.com](http://www.silverinnings.com)  
5.**

**INVITATION for Exhibition: "The Gifted Eye of **Charles Eames**"**

**A Portfolio of 100 images**

**Venue: Design Gallery**

****National Institute of Design****

**Paldi, Ahmedabad**

**Exhibition Time & Date: 10 am to 6 pm (20th to 30th Nov 2008)**

****Introductory Speech** by Eames Demetrios: 10 am - 11 am, 20th November 2008 (Thursday) Venue: NID Auditorium.**

**A Retrospective of Images celebrating the **100th Anniversary** of Charles Eames.**

****Charles and Ray Eames** are arguably the most important American designers of the era.**

**They are best known for their groundbreaking contributions to architecture, furniture design, industrial design and manufacturing but not as well known, for their work in the**

**photographic arts.**

**In this year the 100th year since the birth of Charles, Eames Office with the support of Herman Miller, has created an exhibition of 100 images which has toured Australia, China, Japan and SEA. The exhibition will be in Mumbai (18 Nov.) and NID, Ahmedabad (20th November to 30th November 2008).**

**Eames Demetrios, the grandson of Charles and Ray Eames and the chairman of Eames office, will be there to show you the philosophy of the Eameses.**

**The exhibition will show 100 rarely seen Images from the Eames family collection that shows the many facets of the Eames life and work.**

**For the Eameses, and particularly for Charles, photography was not merely a way to record things. It was a part of the process of viewing through a lens - a critical experience for Charles.**

**The Eameses believed that an Image can be an idea and this exhibition will show the many ideas that came from the creative genius of Charles Eames.**

**The exhibition is created by the Eames office and sponsored by Herman Miller.**

**Planner: EAMES OFFICE**

**Sponsors: Herman Miller, National Institute of Design**

## Program & Events:

1.

Kindly take note of some important upcoming dates for Design

Icubator's Weekend Workshops 18th Nov 08 - **Last date** to

register for UXD01 Introduction to **User Experience Design**

**Fees** For Self Sponsored = 3,000 INR

Fees For Corporate Sponsored = 4,000 INR

18th Nov 08 - Last Date to register to avail Discount on Full Course (if all five Modules booked together)

Fees For Self Sponsored = 32,000 INR

Fees For Corporate Sponsored = 36,000 INR

2nd Dec 08 - Last Date to register to avail Discount on **Core Design Modules** (UXD02 + UXD03+UXD04 if booked together)

Fees For Self Sponsored = 23,000 INR

Fees For Corporate Sponsored = 25,000 INR

2nd Dec 08 - Last Date to register for UXD02 User Requirements Engineering

Fees For Self Sponsored = 8,000 INR

Fees For Corporate Sponsored = 9,000 INR

For details visit: [http://designincubator.com/training\\_current.htm](http://designincubator.com/training_current.htm)

Five workshop modules are offered over weekends spanning from 22nd Nov '08 to 11th Jan '09. Participants can choose to attend the full course or individual modules.

- > UXD 01 - Introduction to User Experience Design (22, 23 Nov 08)
- > UXD 02 - User Requirements Engineering (6,7 Dec 08)
- > UXD 03 - **User Interface** Visualization and **Interaction Design** (13, 14 Dec 08)
- > UXD 04 - Graphic Design and User Interface **Aesthetics** (20, 21 Dec 08)
- > UXD 05 - **Usability Testing** (10, 11 Jan 09)

Download Brochure: [http://designincubator.com/Weekend%](http://designincubator.com/Weekend%0)

**[20Workshops% 20on%20User% 20Experience% 20Design% 20Winter% 202008.pdf](#)**

**Venue**

**Mphasis Ltd., 2nd Floor, Leela Business Park (Opposite to the **Leela Kempinski Hotel**), Andheri-Kurla Road, Andheri East, Mumbai 400059.**

**Facility and Infrastructure support by Mphasis **Usability Engineering** Practice.**

**For any queries feel free to contact us**

**Mail: training[at] [designincubator.com](mailto:training@designincubator.com)**

**Call: +91 (0)22 6552 9069 (speak to Rohit)**

**We look forward to hear from you.**

**Design Incubator R&D Labs Pvt. Ltd.**

**Mail to : [rohit.keluskar@designincubator.com](mailto:rohit.keluskar@designincubator.com)**

**Tel : +91 (0)22 6552 9069**

**2.**

****Product Innovation** Process workshop.**

**The workshop facilitators are from Continuum, USA– Dan Buchner, VP of Innovation and Design, Tom Burchard, VP of Brand Experience and Elephant Strategy + Design, India – Ashish Deshpande, Director and Partho Guha, Director. **The details** of the workshop are as follows:**

**Date Friday, 05th December 2008**

**Time 9.00 AM to 5.30 PM**

**Venue Hotel Deccan Rendezvous,  
1202 /3, Apte Road , Deccan Gymkhana, Pune, 411004**

**Charges Rs. 5, 000 per person  
(Rs. 4, 000 early bird price for registrations until 25th November)**

**Includes instructional fees and materials. Discounts are available to companies that send three or more employees.**

**This one-day workshop will be an interactive journey into the world of innovative thinking. Through short lectures and fast moving and interactive work sessions, the facilitators will take the participants through the innovative thinking process from**

concept to realization. This workshop will accord an extremely good flavor of our methodology of Innovation.

The brochure and nomination form for the workshop can be downloaded from our website [www.elephantiversity.com/pip](http://www.elephantiversity.com/pip).

We look forward to participation from this community. Please direct any queries you have to me.

For more information, please contact:

Hrridaysh Deshpande  
Elephantiversity Institute of Innovation  
t: +91 9921378687  
e: [hrridaysh@elephantiversity.com](mailto:hrridaysh@elephantiversity.com)  
w: [www.elephantiversity.com/pip](http://www.elephantiversity.com/pip)

3.

We at Sarvasva Foundation ( A Division of Sarvasva Designs Pvt Ltd) have taken up an unique initiative to connect people with design during the India Design Festival 2008; and have detailed out a series of events under an overall umbrella of 'Design Intersect', to be held at at ISHANYA, Pune.  
<http://www.ishanya.com/>

Is design for the designer or the consumer? We say it's for both! No product is complete without the inputs of the designer and the interaction of the client and customer.

Likewise, no design festival is complete unless it involves the participation of the design community as well as the `janta'.

Hence Sarvasva Foundation is organising `Design Intersect' – events for the public during the India Design Festival 2008 (IDF) from the 1st -7th December 2008.

Design Intersect will be a `People-Connect' activity and its objective is to take design to the masses. The events will address the introduction, the need of design as well as the various design forms that will connect with the masses. `Design Intersect' will bring design to everybody and this umbrella of smaller events will be focused primarily on bridging the gap between design and the public face of a city.

## **COMPONENTS OF `DESIGN INTERSECT'**

### **1. Dialogues**

Professionals of different fields will engage in informal presentations and discussions with people and students on different topics of design.

### **2. Installations**

From a video wall to sculptures, larger- than- life installations to interaction design, paper to junk – this festival will experience the new and the `next'.

\*Also playing will be different kinds of videos, design films, innovative ads, etc.

The confirmed participating designers are:

a. Hetal Shukla

b. Experiential Design lab- <http://www.experiential-lab.com/eng/> portfolio\_000.htm

c. Origami Mitra - <http://www.origami-mitra.com/>

### **3. Exhibitions**

a. Photography and poetry.

b. Students of design will be given a platform to showcase their innovative streaks. From newly designed bikes and boats to more.

c. Sustainability- a special exhibition by a well-known architect.\*

### **4. Engineering and robotics**

a. Robots on display

b. Industrial Machines with alternative `occupations' .

c. Gadget guru – anything one needs to know about design, technology

and gadgets- ask the GG.\*

... and few more.

This event may be an initiative from an individual company, but the objective is finally for a larger good. An event like 'Design Intersect' has not been conceptualised or organised before in India.

We really feel that every designer, especially those who are in that influential role, should support an event like this, especially because it is an idea for the common good of design.

**PLS NOTE: WE ARE STILL LOOKING FOR SPONSORSHIPS FOR MAKING THIS EVENT HAPPEN. DO LET US KNOW IF YOU CAN HELP WITH THE SAME. THANKS!**

Sarvasva Foundation is also organising its regular `Pune Heritage Walks' on December 7th, 2008 as part of the India



**Design Festival 08, wherein one can get a closer look at the history, culture and architecture of the city of Pune.**

**For more details, contact Darpana or Mukund Athale on [info@sarvasva.com](mailto:info@sarvasva.com) or 9371199433 (Mukund's).**

**Director,  
Sarvasva Foundation,  
Pune.**

**4.**

**International Conference on Research into Design (ICoRD'09)**

**National Seminar Complex, Indian Institute of Science,  
Bangalore, India**

**7-9 January 2009**

**Design is ubiquitous; it pervades almost all spheres of life, and has been around as long as life has taken up the task of purposefully changing the world around it. Research in design and the emergence of a research community in this area has been relatively new, its development influenced by the multiple facets of design (human, artifact, process, organization, and the micro- and macro economy by which design is shaped) and the associated diversification of the community into those focusing on various aspects of these the individual facets, or various applications. Design is complex, balancing the needs from multiple stakeholders, and requiring a multitude of areas of knowledge to be utilized, from resources spread across space and time.**

**ICoRD'09 is the second in a series of conferences intended to be held every two years in India to bring together the international community from diverse areas of design practice, teaching and research to showcase cutting edge research with the stakeholders, aid the ongoing process of developing and extending the collective vision through emerging research challenges and questions, and provide a platform for interaction, collaboration and development of the community in order for it to take up the challenges to realize the vision. It also coincides with the Centennial year of Indian Institute of Science, and is part of the Centennial Celebrations of the Institute. The conference is intended generally for all stakeholders of design, and in particular for practitioners, researchers, teachers and students of design. The**

conference will have:

- a. invited presentations from eminent international experts and practitioners;
- b. presentations of refereed papers as podium, poster, panel or theme presentations;
- c. industrial sessions to present perspectives from industry and studies in practice.

Some example topics of the papers which would be presented for the conference are:

- a. **Design Theory** and Methodology
- b. **Human factors** in Design
- c. Design for X (Product Safety, Design for Manufacture & Assembly, Cost , Reliability, etc)
- d. Enabling Technologies & Tools (**Computer Aided Conceptual Design**, **Virtual Reality**, Haptics, etc)
- e. Design Management, Knowledge management and **Product Life Cycle Management**
- f. Applications in Practice (Automotive, Aerospace, Biomedical Devices, MEMS, etc.)
- g. Eco-Design, **Sustainable Design**, Green Design, Design for Environment
- h. Design Synthesis, **Evaluation** and Optimization
- i. Design Collaboration and Communication
- j. Design Aesthetics, Semiotics, Semantics
- k. Design Training and Education
- l. **Design Research Methodology**

All accepted papers will be published in the proceedings of the conference.

Important dates are:

- Final Papers Due: 1 December 2008
- Registration Deadline: 1 December 2008

Convenor: Prof Amaresh Chakrabarti  
Centre for Product Design and Manufacturing,  
Indian Institute of Science, Bangalore, India;  
Tel: +91 80 2293 2922; Fax: +91 80 2360 1975;  
Email: [ac123@cpdm.iisc.ernet.in](mailto:ac123@cpdm.iisc.ernet.in)

Conference Website: <http://cpdm.iisc.ernet.in/icord'09>

## 5.

**\*60 days to transform India. 25 days to go**

**\***

**The countdown has begun for the PANIIT-AIDI Design Awards.**

**The finalists will be showcased during the Pan IIT conference in IIT Madras on 19th to 21st December. A distinguished panel of jurors, steered by Philippe Vahe, multi-award winning designer, and former designer at Decathlon, France.**

**Google, Tata and SBI are the sponsors.**

**Prize Money: Rs. 50,000 per category.**

**The theme for this year is To \*Inspire, Innovate and Transform\*, which is the also guiding theme of the conference.**

**\*Innovate\* with what you know – which means we are not only looking for blue-sky anything-goes sort of entries, but ones that have constructive thought and look achievable in the foreseeable future.**

**\*Inspire \*new Narratives – Our lives are driven by stories. Some stories are more powerful than the others and these are the ones that bind communities and customers together. An entry has to have a compelling story**

**\*Transform\* India – Designs and design solutions should be in a context of a changing India, and the design idea should enable a positive experience.**

**Award winning entries will reflect an empathetic approach that binds communities and customers together to deliver real-world outcomes.**

**The purpose of the AIDI-PanIIT Design awards is to:**

- Expand national understanding of design as an essential resource for solving the problems around us and envisioning new prosperous futures**
- Introduce innovative ideas to business that can take these ideas towards conclusion**
- Demonstrate how investment in design potentially impacts overall business success**
- Highlight the critical role of design in enhancing quality of life in India.**

**Designs for practically anything may be entered so long as the solution fits into the theme of the competition. Categories represent 'Contexts' and there is no distinction between 'product' and 'service' ideas due to the blurring of boundaries between the two.**

**The categories are:**

### **1. Work and Productivity**

2. Home
3. Infrastructure
4. Healthcare
5. Entertainment and Media
6. Leisure and Personal
7. Automobiles and Transportation

Registration and submission information will soon be available at \* [paniit2008.org/design.php](http://paniit2008.org/design.php)

<<http://paniit2008.org/design.php>> <<http://paniit2008.org/design.php>>

\* Important Dates are:

**November 25:** Open for registration and accepting entries on the website

**December 14:** Last date for submission of entries

**December 15-16th:** Jurying process

**December 17th:** Invitation to finalists to attend Pan-IIT 2008 conference

**December 21st:** Announcement of Best of Category winners  
AIDI coordinator

Social Communication Media (1991)

Sophia Polytechnic Mumbai

6.



## ICAT 2009

The Disabled People's Association is a voluntary welfare organisation which serves as an advocate of all persons with disabilities. In line with its mission to be the Voice of People with Disabilities, it will host the Third International Conference for Accessible Tourism (ICAT) from April 22-24, 2009.

ICAT 2009 aims to bring People with Disabilities to the heart of a more inclusive global society. Themed, 'Tourism Unlimited: Access for All', the event endeavors to break down barriers to accessibility and allow free mobility for all. As this event promotes accessible tourism in the Asia-Pacific region,

**Singapore offers a strategic location as the ICAT's objectives fall in line with the country's aim to become a Global City for All where unlimited access is allowed by universally-designed buildings and facilities.**

**However, more than just a platform for disability issues, ICAT 2009 also serves as a profitable avenue for the tourism sector to explore the many possibilities of expanding their businesses. Accessible tourism is a growing market considering the population increase of the elderly, not to mention expectant mothers, families with young children, apart from people with disabilities who love to travel independently or with care givers and family members. Understanding this promising business venture would surely turn over high economic gains in the long run that will benefit not only travel and tourism companies but also the country itself, particularly its people.**

### **Contact Us**

**DPA Secretariat:**

**Lim Puay Tiak**

**Mobile: (65) 9662 3328 Telephone: (65) 6899 1220 Telefax: (65) 6899 1232**

**Email Address: [secretariat@dpa.org.sg](mailto:secretariat@dpa.org.sg)**

**Conference Secretariat: Jenny Ong**

**Telephone: (65) 6542 2220 , Telefax: (65) 6542 2250**

**7.**



**Welcome to i-CREATe 2009**

**3rd International Convention on Rehabilitation Engineering &  
Assistive Technology  
22 – 26 April, 2009  
Singapore  
"Accessible Tourism"**

## **Important Dates**

**1 Nov 2008: Online submission of paper opens.**

**23 Dec 2008: Submission of 2nd Student Design Challenge entries.**

**12 Jan 2009: Deadline for submission of paper/workshop proposal.**

**30 Jan 2009: Notification of accepted 2nd Student Design Challenge entries.**

**23 Feb 2009: Notification of acceptance of paper/workshop proposal.**

**23 Mar 2009: Deadline for submission of final manuscript.**

## **Conference Secretariats**

**Singapore 415973.**

**Email: [vera\\_yang@start-centre.com](mailto:vera_yang@start-centre.com) OR [icreate2009@start-centre.com](mailto:icreate2009@start-centre.com)**

**Giana M Godoy (START Centre)**

**49 Kaki Bukit View,  
Kaki Bukit TechPark II,  
Singapore 415973.**

**Email: [giana\\_godoy@start-centre.com](mailto:giana_godoy@start-centre.com) OR [icreate2009@start-centre.com](mailto:icreate2009@start-centre.com)**

## Job Opening:

1.

We, at Progress Software Corporation, are looking to hire a UI Designer. Please go through the Company profile and do write to us if you are interested.

Progress Software Corporation, a NASDAQ listed company founded in the year 1981. It has 1600 employees in over 90 countries. It's headquartered in Massachusetts, USA – A worldwide leader in application infra software. It's a pure Product development company and caters to application development, infrastructure software for the development, deployment, integration & management of business applications. They work on SOA Products, Application platform products and Data Infrastructure Products.

Website: <http://www.progress.com>

Your contact at progress:

Shabnam Shaikh

HR, Progress Software Corp.

[shshaikh@progress.com](mailto:shshaikh@progress.com)

2.

An illustrator for a series of Children's books.

She would like the illustrations to be hand done and not computer generated.

If anyone is interested, do mail me back with your contact details at:

[njeyasingh@gmail.com](mailto:njeyasingh@gmail.com)

3.

A posting for a UX Position requirement for PubMatic, Pune. Interested candidate can get in touch with [Krishna.depura@pubmatic.com](mailto:Krishna.depura@pubmatic.com) or [sheetal.shinde@pubmatic.com](mailto:sheetal.shinde@pubmatic.com)

Here is the job description of the positions that we are looking for. We are making some exciting Web products in the field of online advertising and we have pretty exciting and challenging work to offer.

About PubMatic:

<http://www.pubmatic.com/about/>

PubMatic is focused on serving the needs of publishers by providing an industry leading platform that allows publishers to maximize their revenue while simultaneously reducing complexity.

PubMatic is comprised of a dynamic team with experience across a range of industries and company sizes, including leadership positions at established companies such as [Microsoft](#), [SAP](#), [Symantec](#), and [McKinsey & Co.](#) and start-up companies such as [Chipshot.com](#) and [PANTA Systems](#).

We value innovation, creativity, customer service, and integrity. We focus on results and having fun. We also try to do things a little differently at

work, so people can be successful in their professional and personal lives. For example, if you need to go running at 3pm, go run! If you need to start work at 10am because you're not a morning person, start work at 10am. We offer unlimited vacation (you know when you're ready for a break) and every employee in our company receives a full benefits package. We have snacks and drinks for everyone (we'll get whatever you want, just let us know). We have a totally open door policy (actually, there are no offices) and encourage everyone to come up with and follow through on any "bright" ideas to push the company forward! We expect the best from our team so come to work charged and ready to dive in each day!

Also attached is a brief profile for the UX Position.

Kindly contact at the mentioned mail addresses with your folio and resume if you are interested.

[Krishna.depura@pubmatic.com](mailto:Krishna.depura@pubmatic.com) or [sheetal](mailto:sheetal)

4.

**Usability Engineer** will be an integral member of UCD group that specializes in User Experience disciplines

#### Responsibilities

We are looking for a User-savvy individual who can plan and execute usability techniques throughout the **user experience project** life cycle for Web/Desktop based solutions. This Usability Engineer will be responsible for:

- \* Gathering, reviewing, and prioritizing project requirements in collaboration with business and technical teams
- \* Defining user needs, preferences, and behaviors through qualitative and quantitative research/analysis
- \* Documenting usability goals, recommendations and standards/guidelines at appropriate intervals in the project lifecycle
- \* Designing and prototyping user interfaces HTML/PPT/Visio
- \* **Conducting** remote and onsite **usability testing** at various points in the design process (and post-launch)
- \* Collaborating with creative teams and developers to build the front-end interface
- \* Providing close attention to detail in quality reviews to ensure proper integration of the UI with back-end functionality
- \* Conducting usability (heuristic) evaluations and presenting results as a finished report and/or in PPT presentations
- \* Collaborating with the rest of the user experience group to expand, evolve and update techniques, work products and deliverables to reflect latest trends and best practices.

The ideal candidate for the role of Usability Engineer will offer a unique blend of experience, skills and education, such as:



## **Experience:**

- \* 2-4 years in UI design
- \* HTML/CSS expertise required
- \* C,Java language knowledge will be added advantage
- \* Dreamweaver MX experience preferred
- \* Creation of **interaction design prototypes** in multiple formats/media
- \* Familiar with latest usability testing tools/technology required
- \* **Facilitator** of **focus groups** and user testing sessions
- \* Familiar with various techniques and best practices for qualitative and quantitative analysis
- \* Strong writing skills
- \* Cross-industry exposure
- \* Exposure to global solutions with multilingual components

send your resumes to [slourd@gmail.com](mailto:slourd@gmail.com)

5.

## **About Oracle Applications User Experience**

The Applications User Experience group at Oracle (Apps UX) is a centralized team that provides comprehensive interface design, **usability engineering**, and HCI research for Oracle's enterprise applications. Team members have experience in a wide variety of disciplines, including **cognitive psychology**, graphic design, **interaction design**, usability engineering, **Human Computer Interaction** (HCI). The group is spread across Redwood Shores and Pleasanton in California, Denver, **Boston**, Canada, the UK, Bangalore and Hyderabad in India, Thailand and Australia.

The group follows a **user-centered design methodology** that includes activities such as user research, heuristic evaluations, **prototyping**, competitive evaluations of products, and formal **usability testing**. In addition, we manage extensive laboratories for usability evaluations and research projects in areas such as **information visualization**, mobile computing, **universal access**, and distance learning. Advanced projects are also carried out in collaboration with university labs. These labs are located across US, UK, India and other international locations and are equipped with high end equipment to cater to the needs of local and remote usability testing, collaborative design and user research.

Visit <http://ui.us.oracle.com> to know more about the global Oracle Applications User Experience Group.

### **Usability Engineer** (Bangalore / Hyderabad)

The Usability Engineer will have a passion for bringing the users' perspective into the design of new technology products. Successful candidates will work in close collaboration with Oracle's worldwide UX

teams and stakeholders from Strategy and Software Development, to instill and implement the UCD process. As part of the UX team, the Usability Engineer will work on continuously improving the overall user experience throughout the product development lifecycle, and participate in the delivery of **world class enterprise** product releases.

#### **Specific job responsibilities**

- Work closely with other senior usability engineering and interaction design stakeholders to outline overall usability research and test plans. Identify and apply appropriate methods for improving the overall User Experience of **Oracle enterprise products**

- Conduct **high level task** and workflow analyses, usability evaluations, prototype reviews, comparative product analyses, **cognitive walkthroughs**, and user research

- Prepare data collection and research materials for site visits, interviews, surveys, focus groups, and other **contextual inquiry** techniques, analyze and deliver recommendations

- Contribute towards user requirements gathering for new product releases through scenarios and storyboards, **user profiles** and personas, use cases and other methods

- Develop test plans and materials for customer walkthroughs, formative usability assessments and summative usability testing. Recruit and coordinate with test participants, plan testing logistics for key product domains, log usability issues and usability metrics, audio/video recordings, analyze, interpret and report on test findings

- Work with lab administrative staff to run and maintain **usability labs**

- Contribute to Oracle's knowledge base of tools, methods, and best practices through new research on Usability, HCI and Design

#### **Eligibility**

- 3-8 years of usability and user experience activities in the technology products or services industry (consumer or enterprise). Successful application of usability engineering as part of key product launches

- **Experience** in maintaining and using experimental lab setups for data collection with test participants. Skilled in designing and implementing reliable and repeatable experiments

·Experience in applying the **User Centered Design process** for end to end product development cycles

·Familiarity with current usability and HCI research and methods, especially for web and **enterprise software products**. Familiarity with industry standards such as ISO, CIF, and Section 508 guidelines is a plus

·Foundational coursework or relevant experience in different fieldwork methods, including ethnography, usability studies, focus groups, telephonic interviews, user surveys and related approaches, and in statistics and fundamental research techniques

· Familiarity with desktop and enterprise software products is a plus

·Familiarity with basic prototyping tools is a plus

**All candidates must have**

· Ability to collaborate and drive design with multiple global stakeholders in a high velocity **global product development environment**

· Ability to effectively document, articulate and communicate usability value

· Excellent written communication and interpersonal skills

· Ability to work with others in a consultative capacity, quickly build rapport and forge strong working relationships

· Good understanding of research literature in the design and usability field.

Apply with your updated resume and contact number to [abhishek.sharma@oracle.com](mailto:abhishek.sharma@oracle.com) Please note that positions are open only for Bangalore and Hyderabad locations.

**6.**

Renowned newspaper from pune is looking for graphic design firm\* based in pune\* for various **corporate communication requirements**, pl mail me directly if you are interested. i will forward your details to the team.

[abhijitbansod@gmail.com](mailto:abhijitbansod@gmail.com)

**7.**

looking for a web designer with 2-3 years experience.

Should know the following:

HTML, CSS, Dreamweaver, Photoshop (Javascript: Not compulsory but basic knowledge would be an added advantage)

Should possess excellent **communication skills** both written and verbal

Forward the resumes to [amit.bhopi@gmail.com](mailto:amit.bhopi@gmail.com) put the subject in your email as *UINOV08AI*. Emails with a different subject might get ignored.

### About the Company

**The company is one of the biggest financial institutions in the world, the vacancy is for its technology center in Mumbai, preference would be given to candidates already working in Mumbai.**

**8.**

We at **Enterprise Manager User Experience (EMUX)** team at **Oracle** are looking for user **experience designers** in Bangalore. We are looking at recruiting candidates who will contribute to all the different aspects of **user experience design**. As a EMUX team member you will contribute to the product as a **usability engineer**, interaction designer, business analyst and visual designer.

We have opening for two sets of candidates.

#### 1. User Experience Designer

- \* Possess Bachelors, Masters or Ph.D. in Design (Visual Communication, Product Design, Interaction Design, Human Computer Interaction)
- \* Possess 1-5 yrs of professional experience in product development as an individual contributor in Usability within the computer/software industry.
- \* Possess great **visualization skills**
- \* Possess good illustration skills
- \* Experienced in Identity Design and Guidelines.
- \* Possess experimental design knowledge sufficient to plan usability experiments
- \* Possess knowledge of **data analysis tools** and techniques
- \* Experienced in the **Graphic Design applications**
- \* Experienced in Prototyping tools
- \* Possess great **communication skills** to communicate ideas, concepts clearly
- \* Ability to work in a team

#### 2. User Experience Developer

- \* Possess **Bachelors degree** in **Engineering**
- \* Possess 3-5 yrs of professional experience in product development as an individual contributor in developing engaging web applications in **software industry** using Flash/Flex
- \* Experienced in creating interactive prototypes to be used for **usability testing** and Concept Presentations.
- \* Experienced in using HTML, CSS, Javascript, DHTML Flash/Flex

- \* An eye for design and details
- \* A passion for creating engaging applications
- \* Ability to work in a team

If you want to be part of a work environment that allows you to express your potential as a multidimensional user-experience designer, do send us your resume and portfolio (Online/PDF) .

[sourabh.dubey@oracle.com](mailto:sourabh.dubey@oracle.com)  
[rejeeb.mohammed@oracle.com](mailto:rejeeb.mohammed@oracle.com)

You can view more details about these openings on Oracle's recruitment website

1. User Experience Designer
2. User Experience Developer

9.

We have openings for professional model makers 3 posts.

1. Clay Modeller- 1 Post
2. Conventional Model making Skills - 1 Post
- 3 Digital Model maker - 1 Post

Ability to work in a multidisciplinary environment would be preferred. In case you know someone who is interested can ask to get in touch with me directly.

Dy Director  
Symbiosis Institute of Design  
Vimannagar Pune  
020 26634546  
email : [dy\\_director@symbiosisdesign.ac.in](mailto:dy_director@symbiosisdesign.ac.in)

10.

We are looking for some young and enthusiastic [graphic designers](#)/animators for designing and executing identity and packaging for an upcoming news and entertainment channel. Those interested please write in as soon as possible.

[www.circusmotionpictures.com](http://www.circusmotionpictures.com)

11.

Microsoft India Development Center, [Hyderabad](#), has very good opportunity for UX Researcher whose passion and work experience is around user research.

For design and user research professionals, [Microsoft](#) IDC has unique environment where you one would work with talented designers (we don't take recruitments lightly) and would be in the design team which has very good 'brand equity' among development and IDC leadership team.

Here is the job description-

If you want to be part of the most respected [product development environment](#) in [India](#), where UX Research and Design comes before and not after, where UX research and Design activity is seen as integral part of [product development life cycle](#) then read on.

Microsoft India Development Center, **Hyderabad, India** is looking for a Senior UX Researcher.

#### Primary Job Responsibilities

**The Senior** Researcher would be responsible for planning and conducting User Experience Research for products in the following domains -

- Server & Tools
- Consumer applications
- Business and Productivity applications

The senior UX Researcher would put methods and process in place to deliver User Research services to the all product groups that are present at Microsoft India Development Center (MSIDC). A key responsibility would include kick starting and managing the **usability lab**. The researcher would use different methodologies including, surveys, card sorting, **focus groups**, contextual interviews and other creative methods to elicit end user needs and gaps in a software product. The person would understand the business requirements, research the needs of the user, analyze the research data and translate these **findings into meaningful recommendations and actionable items to inform Product Design decisions** at various stages in the product lifecycle. The person would work closely with Product Planners, **Program Managers**, key business stakeholders, Developers and Designers to define and improve the user experience of Microsoft applications.

The ideal person

- Would have at least 8-10 years of industry experience
- Must be skilled at conducting user experience research throughout the product development process with a proven record of informing the product direction and strategy.
- Will be able to develop creative approaches to researching complex user experience problems and can convey ideas in tangible form.
- Specializes in utilizing **appropriate user centered design methodologies and tools in support of product design and development**.
- Has experience writing appropriate discussion guides, survey scripts, test protocols, etc.
- Has experience with online/remote usability tools.
- Is skilled at analyzing both **quantitative and qualitative research** data.
- Can create personas, scenarios and user profile based on research results.
- Will create professional reports and present findings to cross functional teams.
- Has experience working within cross-functional teams and various **levels of management**.
- Must be innovative, demonstrate ability to think out of the box, and think beyond what is asked for.
- Must be able to work independently and drive towards deadlines.
- Must be organized and able to switch rapidly between different projects in a fast-paced and exciting environment.
- Will have excellent written and oral communication skills.

Please contact with your Resume and Portfolio/Work samples:  
Mallika (Recruiter)  
[v-malt@microsoft.com](mailto:v-malt@microsoft.com)

We are also looking for talented **User Experience Designers** (with strong product portfolio, demonstrates that they are versatile designers, and are a great creative problem solvers).

12

**3M** is looking for an **Industrial designer**.  
If interested, please get in touch at [blesenphilip@mmm.com](mailto:blesenphilip@mmm.com) or  
Sundar, <[rmsundar@mmm.com](mailto:rmsundar@mmm.com)>

**Position 1: Industrial Designer**  
**Location: Bangalore, Electronics City**

### **JOB SPECIFICATIONS**

#### **Duties & Responsibilities**

Provide creative design and **support engineering development** of **product design** / **industrial design** programs

Support realizing design mockups / prototyping for other product design / industrial design programs

Provide creative design for **graphic design programs** (signage & product graphics)

Collaborate with converters, engg. Developers to prototype & commercialize above projects

Identify & analyze market trends in related verticals with a view to contemporary product design

#### **Additional Expertise**

1. Proficiency with 2D design tools/software (**Adobe Illustrator**, Photoshop)

2. Proficiency with 3D design tools/software (Rhinoceros, CATiA etc.)

3. Proficiency with prototyping equipment and workflow (Mockups & Prototypes for design evaluation)

Some essential (Minimum Required)

Qualification      BE (Mech. Engg.)

M.Des (Industrial Design)

(IIT-Mumbai, IIT-Delhi OR NID-Ahmedabad ONLY)

Years of **Experience**      3

Nature of Experience      **Product Design**

**Product** Graphics

Experience with prototyping methods

Specific Skills      Sketching,

**Manual & digital rendering techniques  
2D & 3D Design Tools**

13.

Utile Systems, Bangalore (<http://www.utilesystems.com>), have an immediate requirement of a Web cum **Graphic Designer**.

Ideal candidate should:

- 1) be highly creative
- 2) be well versed with design guidelines
- 3) have extensive experience in Photoshop, Flash, **Illustrator** (or **Corel Draw**), CSS, **JavaScript**, etc.
- 4) have an online portfolio to demonstrate his/her work/abilities
- 5) have more than 2 years of experience

Please note that this job will require you to work in sync with the development team.

please send me your resume (along with a link to your online portfolio and a cover letter) at [rahul.bhatt@utilesystems.com](mailto:rahul.bhatt@utilesystems.com)

(More jobs are available in our website [www.designforall.in](http://www.designforall.in) )

**For free Registration: write to**

[subscribe@designforall.in](mailto:subscribe@designforall.in)

**Write to us about change of e-mail address:**

[address@designforall.in](mailto:address@designforall.in)

**Advertising:**



**To advertise in digital Newsletter**

**[advertisement@designforall.in](mailto:advertisement@designforall.in)**

**Acceptance of advertisement does not mean our endorsement of the products or services by the Design for All Institute of India .**

**News and Views:**

**Regarding new products or events or seminars/conferences /workshops.**

**[News@designforall.in](mailto:News@designforall.in)**

**Feedback:**

**Readers are requested to express their views about our newsletter to the Editor**

**[Feedback@designforall.in](mailto:Feedback@designforall.in)**

**Forthcoming Events and Programs:**

**[Editor@designforall.in](mailto:Editor@designforall.in)**

**The views expressed in the signed articles do not necessarily reflect the official views of the Design for All Institute of India.**

**Chief-Editor:**

**Dr .Sunil Kumar Bhatia Faculty Member,  
13, Lodhi Institutional Area, Lodhi Road,  
New Delhi-110003(INDIA)**

**Editor:**

**Shri L .K .Das**

**Prof& Head Industrial Design Centre, Indian Institute of Technology (Delhi), India**

**Associate Editor:**

**Shri. Amitav Bhowmick Industrial Designer Small Industries Service Institute. Ministry of Small scale, Government Of India, Delhi (INDIA)**

**Editorial Board:**

**Mr. M.L .Dhawan**

**Mr. Pankaj Sharma**

**Mr. Pramod Chauhan**

## Special Correspondent:

Ms Nemisha Sharma

Mumbai, India

[Nemisha.17@hotmail.com](mailto:Nemisha.17@hotmail.com)

## Contributors:



*visiting faculty in Customer Relationship Management at the premier Kerala Institute of Travel and Tourism Studies in Trivandrum .India [sonimail@gmail.com](mailto:sonimail@gmail.com)*



*Dr Rains Scott*

**Editor, founder Rolling Rains Report,**

<[srains@oco.net](mailto:srains@oco.net)>, <http://www.RollingRains.com>



*Prof Ms Ketna L Mehta s editor and Associate Dean,  
Research with. [www.ninafoundation.org](http://www.ninafoundation.org)*

[ketna@vsnl.com](mailto:ketna@vsnl.com) [ketnam@gmail.com](mailto:ketnam@gmail.com)



**Vikas Sharma**

*Chief Access Consultant, AccessAbility, India*

[www.AccessAbility.co.in](http://www.AccessAbility.co.in)



*Sherri Backstrom, Director  
co-owner of Waypoint Yacht Charter Services*

[sherri@waypointcharter.com](mailto:sherri@waypointcharter.com)



*Shivani Gupta Director ,AccessAbility | Delhi*

[shivani@accessability.co.in](mailto:shivani@accessability.co.in) [www.AccessAbility.co.in](http://www.AccessAbility.co.in)



**Mr. J. Bharat IIT-Delhi, IDC , India**

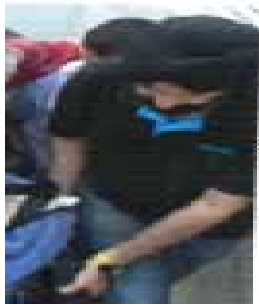

**Mr Amitoj Singh , IIT-Delhi, IDC ,India**

**Address for Correspondence:**

**13, Lodhi Institutional Area,  
Lodhi Road, New Delhi-110 003India.**

**Material appearing in this Newsletter may be  
freely reproduced . A copy of the same and  
acknowledgement would be appreciated.**

**This Newsletter is published monthly, by Design for All  
Institute of India, 13 Lodhi Institutional Area, Lodhi Road,**

**New Delhi-110 003 (INDIA)**

**Tel: +91-11-27853470**

**E-Mail: [newsletter@designforall.in](mailto:newsletter@designforall.in)**

**Website: [www.designforall.in](http://www.designforall.in)**

**Cover Design: Mr. Pudi Ravi ([pudiravi@gmail.com](mailto:pudiravi@gmail.com) )**

**(Photo of Taj Mahal on cover, courtesy Dr Rains Scott)  
)**